

(12) INTERNATIONAL APPLICATION PUBLISHED UNDER THE PATENT COOPERATION TREATY (PCT)

(19) World Intellectual Property Organization  
International Bureau



INTERNATIONAL BUREAU OF PATENT COOPERATION  
358, RUE DE LA LIBÉRIÉ, CHAMBERLIN, SUISSE  
P.O. BOX 6859, GENÈVE, SUISSE  
4800, RUE DE LA LIBÉRIÉ, CHAMBERLIN, SUISSE  
P.O. BOX 6859, GENÈVE, SUISSE

(43) International Publication Date  
22 May 2003 (22.05.2003)

PCT

(10) International Publication Number  
WO 03/042487 A2

- (51) International Patent Classification<sup>7</sup>: E21B
- (21) International Application Number: PCT/US02/36267
- (22) International Filing Date:  
12 November 2002 (12.11.2002)
- (25) Filing Language: English
- (26) Publication Language: English
- (30) Priority Data:  
60/339,013 12 November 2001 (12.11.2001) US  
60/338,996 12 November 2001 (12.11.2001) US  
60/363,829 13 March 2002 (13.03.2002) US  
60/387,961 12 June 2002 (12.06.2002) US
- (71) Applicant (for all designated States except US): ENVEN-  
TURE GLOBAL TECHNOLOGY [USA/US]; 16200 A Park  
Row, Houston, TX 77084 (US).
- (72) Inventors: and
- (75) Inventors/Applicants (for US only): RING, Lev  
[RU/US]; 14126 Heatherhill Place, Houston, TX 77077  
(US). BRISCO, David, Paul [US/US]; 405 Westridge  
Drive, Duncan, OK 73533 (US). WATSON, Brock,  
Wayne [US/US]; 2535 Marsh Lane #1004, Carnation,  
TX 75006 (US). WADDELL, Kevin, K. [US/US]; 11007  
Sprucedale Court, Houston, TX 77070 (US).
- (74) Agents: MATTINGLY, Todd et al.; Haynes and Boone,  
LLP, Suite 4300, 1000 Louisiana Street, Houston, TX  
77002-5012 (US).
- (81) Designated States (national): AE, AG, AL, AM, AT, AU,  
AZ, BA, BB, BG, BR, BY, BZ, CA, CH, CN, CO, CR, CU,  
CZ, DE, DK, DM, DZ, EC, EE, ES, FI, GB, GD, GE, GH,  
GM, HR, HU, ID, IL, IN, IS, JP, KE, KG, KP, KR, KZ, LC,  
LK, LR, LS, LT, LU, LV, MA, MD, MG, MK, MN, MW,  
MX, MZ, NO, NZ, PL, PT, RO, RU, SD, SE, SG, SI, SK.

[Continued on next page]

(54) Title: MONO DIAMETER WELLBORE CASING

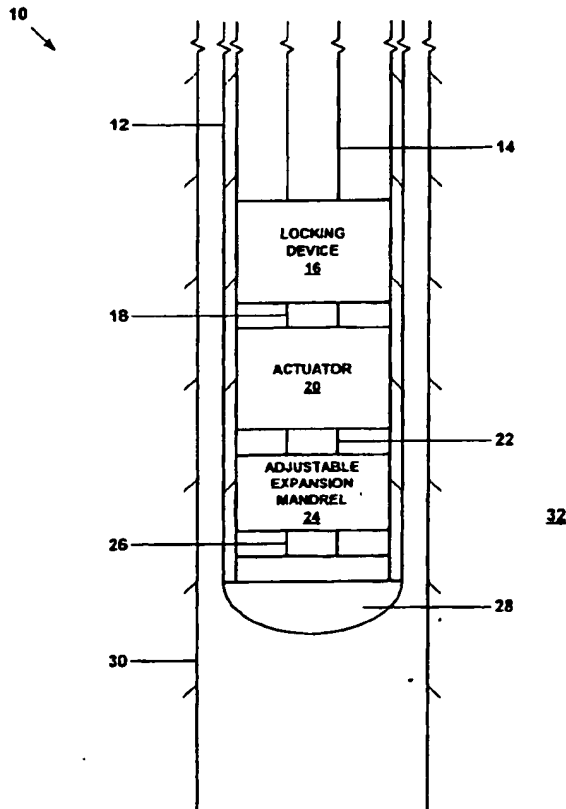

(57) Abstract: An apparatus and method for forming a mono diameter wellbore casing.



WO 03/042487 A2



SL, TJ, TM, TR, TT, TZ, UA, UG, US, UZ, VN, YU, ZA, ZW.

**Declaration under Rule 4.17:**

— of inventorship (Rule 4.17(iv)) for US only

(84) Designated States (regional): ARIPO patent (GH, GM, KI, LS, MW, MZ, SD, SL, SZ, TZ, UG, ZM, ZW), Eurasian patent (AM, AZ, BY, KG, KZ, MD, RU, TJ, TM), European patent (AT, BE, BG, CH, CY, CZ, DE, DK, EE, ES, FI, FR, GB, GR, IE, IT, LU, MC, NL, PT, SE, SK, TR), OAPI patent (BF, BJ, CF, CG, CI, CM, GA, GN, GQ, GW, ML, MR, NE, SN, TD, TG).

**Published:**

-- without international search report and to be republished upon receipt of that report

For two-letter codes and other abbreviations, refer to the "Guidance Notes on Codes and Abbreviations" appearing at the beginning of each regular issue of the PCT Gazette.

**MONO DIAMETER WELLBORE CASING****Cross Reference To Related Applications**

[0001] The present application claims the benefit of the filing dates of: (1) U.S. provisional patent application serial no. 60/338,996, attorney docket no. 25791.87, filed on 11/12/2001, (2) U.S. provisional patent application serial no. 60/339,013, attorney docket no. 88, filed on 11/12/01 (3) U.S. provisional patent application serial no. 60/363,829, attorney docket no. 25791.95, filed on 3/13/2002, (4) U.S. provisional patent application serial no. 60/387,961, attorney docket no. 25791.108, filed on 6/12/2002 the disclosures of which are incorporated herein by reference.

[0002] The present application is related to the following: (1) U.S. patent application serial no. 09/454,139, attorney docket no. 25791.03.02, filed on 12/3/1999, (2) U.S. patent application serial no. 09/510,913, attorney docket no. 25791.7.02, filed on 2/23/2000, (3) U.S. patent application serial no. 09/502,350, attorney docket no. 25791.8.02, filed on 2/10/2000, (4) U.S. patent no. 6,328,113, (5) U.S. patent application serial no. 09/523,460, attorney docket no. 25791.11.02, filed on 3/10/2000, (6) U.S. patent application serial no. 09/512,895, attorney docket no. 25791.12.02, filed on 2/24/2000, (7) U.S. patent application serial no. 09/511,941, attorney docket no. 25791.16.02, filed on 2/24/2000, (8) U.S. patent application serial no. 09/588,946, attorney docket no. 25791.17.02, filed on 6/7/2000, (9) U.S. patent application serial no. 09/559,122, attorney docket no. 25791.23.02, filed on 4/26/2000, (10) PCT patent application serial no. PCT/US00/18635, attorney docket no. 25791.25.02, filed on 7/9/2000, (11) U.S. provisional patent application serial no. 60/162,671, attorney docket no. 25791.27, filed on 11/1/1999, (12) U.S. provisional patent application serial no. 60/154,047, attorney docket no. 25791.29, filed on 9/16/1999, (13) U.S. provisional patent application serial no. 60/159,082, attorney docket no. 25791.34, filed on 10/12/1999, (14) U.S. provisional patent application serial no. 60/159,039, attorney docket no. 25791.36, filed on 10/12/1999, (15) U.S. provisional patent application serial no. 60/159,033, attorney docket no. 25791.37, filed on 10/12/1999, (16) U.S. provisional patent application serial no. 60/212,359, attorney docket no. 25791.38, filed on 6/19/2000, (17) U.S. provisional patent application serial no. 60/165,228, attorney docket no. 25791.39, filed on 11/12/1999, (18) U.S. provisional patent application serial no. 60/221,443, attorney docket no. 25791.45, filed on 7/28/2000, (19) U.S. provisional patent application serial no. 60/221,645, attorney docket no. 25791.46, filed on 7/28/2000, (20) U.S. provisional patent application serial no. 60/233,638, attorney docket no. 25791.47, filed on 9/18/2000, (21) U.S. provisional patent application serial no. 60/237,334, attorney docket no. 25791.48, filed on 10/2/2000, (22) U.S. provisional patent application serial no. 60/270,007, attorney docket no. 25791.50, filed on 2/20/2001, (23) U.S. provisional patent application serial no. 60/262,434, attorney docket no. 25791.51, filed on 1/17/2001, (24) U.S. provisional patent application serial no. 60/259,486, attorney docket no. 25791.52, filed on 1/3/2001, (25) U.S. provisional patent application serial no. 60/303,740, attorney docket no. 25791.61, filed on 7/6/2001, (26) U.S. provisional patent application serial no. 60/313,453, attorney docket no. 25791.59, filed on 8/20/2001, (27) U.S.

provisional patent application serial no. 60/317,985, attorney docket no. 25791.67, filed on 9/6/2001, (28) U.S. provisional patent application serial no. 60/318,021, attorney docket no. 25791.58, filed on 9/7/2001, (29) U.S. provisional patent application serial no. 60/3318,386, attorney docket no. 25791.67.02, filed on 9/10/2001, (30) U.S. provisional patent application serial no. 60/326,886, attorney docket no. 25791.60, filed on 10/3/2001, (31) U.S. utility patent application serial no. 09/969,922, attorney docket no. 25791.69, filed on 10/3/2001, (32) U.S. provisional patent application serial no. 60/338,996, attorney docket no. 25791.87, filed on 11/12/2001, (33) U.S. provisional patent application serial no. 60/339,013, attorney docket no. 25791.88, filed on 11/12/2001, (34) U.S. utility patent application serial no. 10/016,467, attorney docket no. 25791.70, filed on 12/10/2001, (35) U.S. provisional patent application serial no. 60/343,674, attorney docket no. 25791.68, filed on 12/27/2001, (36) U.S. provisional patent application serial no. 60/346,309, attorney docket no. 25791.92, filed on 1/7/2002, (37) U.S. provisional patent application serial no. 60/357,372, attorney docket no. 25791.71, filed on 2/15/2002, (38) U.S. provisional patent application serial no. 60/363,829, attorney docket no. 25791.95, filed on 3/13/2002, (39) U.S. provisional patent application serial no. 60/372,048, attorney docket no. 25791.93, filed on 4/12/2002, (40) U.S. provisional patent application serial no. 60/372,632, attorney docket no. 25791.101, filed on 4/15/2002, (41) U.S. provisional patent application serial no. 60/380,147, attorney docket no. 25791.104, filed on 5/6/2002, (42) U.S. provisional patent application serial no. 60/383,917, attorney docket no. 25791.89, filed on 5/29/2002, (43) U.S. provisional patent application serial no. 60/387,486, attorney docket no. 25791.107, filed on 6/10/2002, (44) U.S. provisional patent application serial no. 60/387,961, attorney docket no. 25791.108, filed on 6/12/2002, (45) U.S. provisional patent application serial no. 60/391,703, attorney docket no. 25791.90, filed on 6/26/2002, (46) U.S. provisional patent application serial no. 60/397,284, attorney docket no. 25791.106, filed on 7/19/2002, (47) U.S. provisional patent application serial no. 60/398,061, attorney docket no. 25791.110, filed on 7/24/2002, (48) U.S. provisional patent application serial no. 60/399,240, attorney docket no. 25791.111, filed on 7/29/2002, (49) U.S. provisional patent application serial no. 60/405,610, attorney docket no. 25791.119, filed on 8/23/2002, (50) U.S. provisional patent application serial no. 60/405,394, attorney docket no. 25791.120, filed on 8/23/2002, (51) U.S. provisional patent application serial no. 60/407,442, attorney docket no. 25791.125, filed on 8/30/2002, (52) U.S. provisional patent application serial no. 60/412,542, attorney docket no. 25791.102, filed on 9/20/2002, (53) U.S. provisional patent application serial no. 60/412,177, attorney docket no. 25791.117, filed on 9/20/2002, (54) U.S. provisional patent application serial no. 60/412,653, attorney docket no. 25791.118, filed on 9/20/2002, (55) U.S. provisional patent application serial no. 60/412,544, attorney docket no. 25791.121, filed on 9/20/2002, (56) U.S. provisional patent application serial no. 60/412,187, attorney docket no. 25791.128, filed on 9/20/2002, (57) U.S. provisional patent application serial no. 60/412,187, attorney docket no. 25791.127, filed on 9/20/2002, (58) U.S. provisional patent application serial no. 60/412,487, attorney docket no. 25791.127, filed on 9/20/2002, (58) U.S. provisional patent application serial no. 60/412,487, attorney docket no. 25791.112, filed on



9/20/2002, (59) U.S. provisional patent application serial no. 60/412,488, attorney docket no. 25791.114, filed on 9/20/2002, and (60) U.S. provisional patent application serial no. 60/412,371, attorney docket no. 25791.129, filed on 9/20/2002, (61) PCT Patent Application No. PCT/US02\_\_\_\_\_, attorney docket no. 25791.87.02, filed on 11/11/02 and (62) PCT Patent Application No. PCT/US02\_\_\_\_\_, attorney docket no. 25791.88.02, filed on 11/11/02 the disclosures of which are incorporated herein by reference.

#### Background Of The Invention

[0003] This invention relates generally to oil and gas exploration, and in particular to forming and repairing wellbore casings to facilitate oil and gas exploration.

[0004] Conventionally, when a wellbore is created, a number of casings are installed in the borehole to prevent collapse of the borehole wall and to prevent undesired outflow of drilling fluid into the formation or inflow of fluid from the formation into the borehole. The borehole is drilled in intervals whereby a casing which is to be installed in a lower borehole interval is lowered through a previously installed casing of an upper borehole interval. As a consequence of this procedure the casing of the lower interval is of smaller diameter than the casing of the upper interval. Thus, the casings are in a nested arrangement with casing diameters decreasing in downward direction. Cement annuli are provided between the outer surfaces of the casings and the borehole wall to seal the casings from the borehole wall. As a consequence of this nested arrangement a relatively large borehole diameter is required at the upper part of the wellbore. Such a large borehole diameter involves increased costs due to heavy casing handling equipment, large drill bits and increased volumes of drilling fluid and drill cuttings. Moreover, increased drilling rig time is involved due to required cement pumping, cement hardening, required equipment changes due to large variations in hole diameters drilled in the course of the well, and the large volume of cuttings drilled and removed.

[0005] The present invention is directed to overcoming one or more of the limitations of the existing procedures for forming and/or repairing wellbore casings.

#### Summary of the Invention

[0010] According to one aspect of the present invention, an apparatus for radially expanding and plastically deforming an expandable tubular member is provided that includes a float shoe adapted to mate with an end of the expandable tubular member, an adjustable expansion mandrel coupled to the float shoe adapted to be controllably expanded to a larger outside dimension for radial expansion of the expandable tubular member or collapsed to a smaller outside dimension, an actuator coupled to the adjustable expansion mandrel adapted to controllably displace the adjustable expansion mandrel relative to the expandable tubular member, a locking device coupled to the actuator adapted to controllably engage the expandable tubular member, and a support member coupled to the locking device.

[0011] According to another aspect of the present invention, a method for radially expanding and plastically deforming an expandable tubular member within a borehole is provided that includes

positioning an adjustable expansion mandrel within the expandable tubular member, supporting the expandable tubular member and the adjustable expansion mandrel within the borehole, lowering the adjustable expansion mandrel out of the expandable tubular member, increasing the outside dimension of the adjustable expansion mandrel, and displacing the adjustable expansion mandrel upwardly relative to the expandable tubular member  $n$  times to radially expand and plastically deform  $n$  portions of the expandable tubular member.

[0012] According to another aspect of the present invention, a method for forming a mono diameter wellbore casing is provided that includes positioning an adjustable expansion mandrel within a first expandable tubular member, supporting the first expandable tubular member and the adjustable expansion mandrel within a borehole, lowering the adjustable expansion mandrel out of the first expandable tubular member, increasing the outside dimension of the adjustable expansion mandrel, displacing the adjustable expansion mandrel upwardly relative to the first expandable tubular member  $m$  times to radially expand and plastically deform  $m$  portions of the first expandable tubular member within the borehole, positioning the adjustable expansion mandrel within a second expandable tubular member, supporting the second expandable tubular member and the adjustable expansion mandrel within the borehole in overlapping relation to the first expandable tubular member, lowering the adjustable expansion mandrel out of the second expandable tubular member, increasing the outside dimension of the adjustable expansion mandrel, and displacing the adjustable expansion mandrel upwardly relative to the second expandable tubular member  $n$  times to radially expand and plastically deform  $n$  portions of the second expandable tubular member within the borehole.

[0013] According to another aspect of the present invention, an apparatus for radially expanding and plastically deforming an expandable tubular member is provided that includes a float shoe adapted to mate with an end of the expandable tubular member, an adjustable expansion mandrel coupled to the float shoe adapted to be controllably expanded to a larger outside dimension for radial expansion of the expandable tubular member or collapsed to a smaller outside dimension, an actuator coupled to the adjustable expansion mandrel adapted to controllably displace the adjustable expansion mandrel relative to the expandable tubular member, a locking device coupled to the actuator adapted to controllably engage the expandable tubular member, a support member coupled to the locking device, and a sealing member for sealingly engaging the expandable tubular member adapted to define a pressure chamber above the adjustable expansion mandrel during radial expansion of the expandable tubular member.

[0014] According to another aspect of the present invention, a method for radially expanding and plastically deforming an expandable tubular member within a borehole is provided that includes positioning an adjustable expansion mandrel within the expandable tubular member, supporting the expandable tubular member and the adjustable expansion mandrel within the borehole, lowering the adjustable expansion mandrel out of the expandable tubular member, increasing the outside dimension of the adjustable expansion mandrel, displacing the adjustable expansion mandrel upwardly relative to

the expandable tubular member  $n$  times to radially expand and plastically deform  $n$  portions of the expandable tubular member within the borehole, and pressurizing an interior region of the expandable tubular member above the adjustable expansion mandrel during the radial expansion and plastic deformation of the expandable tubular member within the borehole.

[0015] According to another aspect of the present invention, a method for forming a mono diameter wellbore casing is provided that includes positioning an adjustable expansion mandrel within a first expandable tubular member, supporting the first expandable tubular member and the adjustable expansion mandrel within a borehole, lowering the adjustable expansion mandrel out of the first expandable tubular member, increasing the outside dimension of the adjustable expansion mandrel, displacing the adjustable expansion mandrel upwardly relative to the first expandable tubular member  $m$  times to radially expand and plastically deform  $m$  portions of the first expandable tubular member within the borehole, pressurizing an interior region of the first expandable tubular member above the adjustable expansion mandrel during the radial expansion and plastic deformation of the first expandable tubular member within the borehole, positioning the adjustable expansion mandrel within a second expandable tubular member, supporting the second expandable tubular member and the adjustable expansion mandrel within the borehole in overlapping relation to the first expandable tubular member, lowering the adjustable expansion mandrel out of the second expandable tubular member, increasing the outside dimension of the adjustable expansion mandrel, displacing the adjustable expansion mandrel upwardly relative to the second expandable tubular member  $n$  times to radially expand and plastically deform  $n$  portions of the second expandable tubular member within the borehole, and pressurizing an interior region of the second expandable tubular member above the adjustable expansion mandrel during the radial expansion and plastic deformation of the second expandable tubular member within the borehole.

[0016] According to another aspect of the present invention, an apparatus for drilling a borehole within a subterranean formation and then radially expanding and plastically deforming an expandable tubular member within the drilled borehole is provided that includes a float shoe adapted to mate with an end of the expandable tubular member, a drilling member coupled to the float shoe adapted to drill the borehole, an adjustable expansion mandrel coupled to the float shoe adapted to be controllably expanded to a larger outside dimension for radial expansion of the expandable tubular member or collapsed to a smaller outside dimension, an actuator coupled to the adjustable expansion mandrel adapted to controllably displace the adjustable expansion mandrel relative to the expandable tubular member, a locking device coupled to the actuator adapted to controllably engage the expandable tubular member, and a support member coupled to the locking device.

[0017] According to another aspect of the present invention, a method for drilling a borehole within a subterranean formation and then radially expanding and plastically deforming an expandable tubular member within the drilled borehole is provided that include positioning an adjustable expansion mandrel within the expandable tubular member, coupling a drilling member to an end of the expandable

tubular member, drilling the borehole using the drilling member, positioning the adjustable expansion mandrel and the expandable tubular member within the drilled borehole, lowering the adjustable expansion mandrel out of the expandable tubular member, increasing the outside dimension of the adjustable expansion mandrel, and displacing the adjustable expansion mandrel upwardly relative to the expandable tubular member  $n$  times to radially expand and plastically deform  $n$  portions of the expandable tubular member within the drilled borehole.

[0018] According to another aspect of the present invention, a method for forming a mono diameter wellbore casing within a borehole is provided that includes positioning an adjustable expansion mandrel within a first expandable tubular member, coupling a drilling member to an end of the first expandable tubular member, drilling a first section of the borehole using the drilling member, supporting the first expandable tubular member and the adjustable expansion mandrel within the drilled first section of the borehole, lowering the adjustable expansion mandrel out of the first expandable tubular member, increasing the outside dimension of the adjustable expansion mandrel, displacing the adjustable expansion mandrel upwardly relative to the first expandable tubular member  $m$  times to radially expand and plastically deform  $m$  portions of the first expandable tubular member within the drilled first section of the borehole, positioning the adjustable expansion mandrel within a second expandable tubular member, coupling the drilling member to an end of the second expandable tubular member, drilling a second section of the borehole using the drilling member, supporting the second expandable tubular member and the adjustable expansion mandrel within the borehole in overlapping relation to the first expandable tubular member within the second drilled section of the borehole, lowering the adjustable expansion mandrel out of the second expandable tubular member, increasing the outside dimension of the adjustable expansion mandrel, and displacing the adjustable expansion mandrel upwardly relative to the second expandable tubular member  $n$  times to radially expand and plastically deform  $n$  portions of the second expandable tubular member within the drilled second section of the borehole.

[0019] According to another aspect of the present invention, an apparatus for drilling a borehole within a subterranean formation and then radially expanding and plastically deforming an expandable tubular member within the drilled borehole is provided that includes a float shoe adapted to mate with an end of the expandable tubular member, a drilling member coupled to the float shoe adapted to drill the borehole, an adjustable expansion mandrel coupled to the float shoe adapted to be controllably expanded to a larger outside dimension for radial expansion of the expandable tubular member or collapsed to a smaller outside dimension, an actuator coupled to the adjustable expansion mandrel adapted to controllably displace the adjustable expansion mandrel relative to the expandable tubular member, a locking device coupled to the actuator adapted to controllably engage the expandable tubular member, a support member coupled to the locking device, and a sealing member for sealing engaging the expandable tubular member adapted to define a pressure chamber above the adjustable expansion mandrel during the radial expansion of the expandable tubular member.

[0020] According to another aspect of the present invention, a method for drilling a borehole within a subterranean formation and then radially expanding and plastically deforming an expandable tubular member within the drilled borehole is provided that includes positioning an adjustable expansion mandrel within the expandable tubular member, coupling a drilling member to an end of the expandable tubular member, drilling the borehole using the drilling member, positioning the adjustable expansion mandrel and the expandable tubular member within the drilled borehole, lowering the adjustable expansion mandrel out of the expandable tubular member, increasing the outside dimension of the adjustable expansion mandrel, displacing the adjustable expansion mandrel upwardly relative to the expandable tubular member  $n$  times to radially expand and plastically deform  $n$  portions of the expandable tubular member within the drilled borehole, and pressuring an interior portion of the expandable tubular member above the adjustable expansion mandrel during the radial expansion and plastic deformation of the expandable tubular member within the drilled borehole.

[0021] According to another aspect of the present invention, a method for forming a mono diameter wellbore casing within a borehole is provided that includes positioning an adjustable expansion mandrel within a first expandable tubular member, coupling a drilling member to an end of the first expandable tubular member, drilling a first section of the borehole using the drilling member, supporting the first expandable tubular member and the adjustable expansion mandrel within the drilled first section of the borehole, lowering the adjustable expansion mandrel out of the first expandable tubular member, increasing the outside dimension of the adjustable expansion mandrel, displacing the adjustable expansion mandrel upwardly relative to the first expandable tubular member  $m$  times to radially expand and plastically deform  $m$  portions of the first expandable tubular member within the drilled first section of the borehole, pressuring an interior portion of the first expandable tubular member above the adjustable expansion mandrel during the radial expansion and plastic deformation of the first expandable tubular member within the first drilled section of the borehole, positioning the adjustable expansion mandrel within a second expandable tubular member, coupling the drilling member to an end of the second expandable tubular member, drilling a second section of the borehole using the drilling member, supporting the second expandable tubular member and the adjustable expansion mandrel within the borehole in overlapping relation to the first expandable tubular member within the second drilled section of the borehole, lowering the adjustable expansion mandrel out of the second expandable tubular member, increasing the outside dimension of the adjustable expansion mandrel, displacing the adjustable expansion mandrel upwardly relative to the second expandable tubular member  $n$  times to radially expand and plastically deform  $n$  portions of the second expandable tubular member within the drilled second section of the borehole, and pressuring an interior portion of the second expandable tubular member above the adjustable expansion mandrel during the radial expansion and plastic deformation of the second expandable tubular member within the drilled second section of the borehole.

[0022] According to another aspect of the present invention, an apparatus for radially expanding and plastically deforming an expandable tubular member is provided that includes a float shoe adapted to mate with an end of the expandable tubular member, a first adjustable expansion mandrel coupled to the float shoe adapted to be controllably expanded to a first larger outside dimension for radial expansion of the expandable tubular member or collapsed to a first smaller outside dimension, a second adjustable expansion mandrel coupled to the first adjustable expansion mandrel adapted to be controllably expanded to a second larger outside dimension for radial expansion of the expandable tubular member or collapsed to a second smaller outside dimension, an actuator coupled to the first and second adjustable expansion mandrels adapted to controllably displace the first and second adjustable expansion mandrels relative to the expandable tubular member, a locking device coupled to the actuator adapted to controllably engage the expandable tubular member, and a support member coupled to the locking device. The first larger outside dimension of the first adjustable expansion mandrel is larger than the second larger outside dimension of the second adjustable expansion mandrel.

[0023] According to another aspect of the present invention, a method for radially expanding and plastically deforming an expandable tubular member within a borehole is provided that includes positioning first and second adjustable expansion mandrels within the expandable tubular member, supporting the expandable tubular member and the first and second adjustable expansion mandrels within the borehole, lowering the first adjustable expansion mandrel out of the expandable tubular member, increasing the outside dimension of the first adjustable expansion mandrel, displacing the first adjustable expansion mandrel upwardly relative to the expandable tubular member to radially expand and plastically deform a lower portion of the expandable tubular member, displacing the first adjustable expansion mandrel and the second adjustable expansion mandrel downwardly relative to the expandable tubular member, decreasing the outside dimension of the first adjustable expansion mandrel and increasing the outside dimension of the second adjustable expansion mandrel, and displacing the second adjustable expansion mandrel upwardly relative to the expandable tubular member to radially expand and plastically deform portions of the expandable tubular member above the lower portion of the expandable tubular member. The outside dimension of the first adjustable expansion mandrel is greater than the outside dimension of the second adjustable expansion mandrel.

[0024] According to another aspect of the present invention, a method for forming a mono diameter wellbore casing is provided that includes positioning first and second adjustable expansion mandrels within a first expandable tubular member, supporting the first expandable tubular member and the first and second adjustable expansion mandrels within a borehole, lowering the first adjustable expansion mandrel out of the first expandable tubular member, increasing the outside dimension of the first adjustable expansion mandrel, displacing the first adjustable expansion mandrel upwardly relative to the first expandable tubular member to radially expand and plastically deform a lower portion of the first expandable tubular member, displacing the first adjustable expansion mandrel and the second adjustable expansion mandrel downwardly relative to the first expandable tubular member, decreasing

the outside dimension of the first adjustable expansion mandrel and increasing the outside dimension of the second adjustable expansion mandrel, displacing the second adjustable expansion mandrel upwardly relative to the first expandable tubular member to radially expand and plastically deform portions of the first expandable tubular member above the lower portion of the expandable tubular member, positioning first and second adjustable expansion mandrels within a second expandable tubular member, supporting the first expandable tubular member and the first and second adjustable expansion mandrels within the borehole in overlapping relation to the first expandable tubular member, lowering the first adjustable expansion mandrel out of the second expandable tubular member, increasing the outside dimension of the first adjustable expansion mandrel, displacing the first adjustable expansion mandrel upwardly relative to the second expandable tubular member to radially expand and plastically deform a lower portion of the second expandable tubular member, displacing the first adjustable expansion mandrel and the second adjustable expansion mandrel downwardly relative to the second expandable tubular member, decreasing the outside dimension of the first adjustable expansion mandrel and increasing the outside dimension of the second adjustable expansion mandrel, and displacing the second adjustable expansion mandrel upwardly relative to the second expandable tubular member to radially expand and plastically deform portions of the second expandable tubular member above the lower portion of the second expandable tubular member. The outside dimension of the first adjustable expansion mandrel is greater than the outside dimension of the second adjustable expansion mandrel.

[0025] According to another aspect of the present invention, an apparatus for radially expanding and plastically deforming an expandable tubular member is provided that includes a float shoe adapted to mate with an end of the expandable tubular member, a first adjustable expansion mandrel coupled to the float shoe adapted to be controllably expanded to a first larger outside dimension for radial expansion of the expandable tubular member or collapsed to a first smaller outside dimension, a second adjustable expansion mandrel coupled to the first adjustable expansion mandrel adapted to be controllably expanded to a second larger outside dimension for radial expansion of the expandable tubular member or collapsed to a second smaller outside dimension, an actuator coupled to the first and second adjustable expansion mandrels adapted to controllably displace the first and second adjustable expansion mandrels relative to the expandable tubular member, a locking device coupled to the actuator adapted to controllably engage the expandable tubular member, a support member coupled to the locking device, and a sealing member for sealingly engaging the expandable tubular adapted to define a pressure chamber above the first and second adjustable expansion mandrels during the radial expansion of the expandable tubular member. The first larger outside dimension of the first adjustable expansion mandrel is larger than the second larger outside dimension of the second adjustable expansion mandrel.

[0026] According to another aspect of the present invention, a method for radially expanding and plastically deforming an expandable tubular member within a borehole is provided that includes positioning first and second adjustable expansion mandrels within the expandable tubular member, supporting the expandable tubular member and the first and second adjustable expansion mandrels

within the borehole, lowering the first adjustable expansion mandrel out of the expandable tubular member, increasing the outside dimension of the first adjustable expansion mandrel, displacing the first adjustable expansion mandrel upwardly relative to the expandable tubular member to radially expand and plastically deform a lower portion of the expandable tubular member, pressurizing an interior region of the expandable tubular member above the first adjustable expansion mandrel during the radial expansion of the lower portion of the expandable tubular member by the first adjustable expansion mandrel, displacing the first adjustable expansion mandrel and the second adjustable expansion mandrel downwardly relative to the expandable tubular member, decreasing the outside dimension of the first adjustable expansion mandrel and increasing the outside dimension of the second adjustable expansion mandrel, displacing the second adjustable expansion mandrel upwardly relative to the expandable tubular member to radially expand and plastically deform portions of the expandable tubular member above the lower portion of the expandable tubular member, and pressurizing an interior region of the expandable tubular member above the second adjustable expansion mandrel during the radial expansion of the portions of the expandable tubular member above the lower portion of the expandable tubular member by the second adjustable expansion mandrel. The outside dimension of the first adjustable expansion mandrel is greater than the outside dimension of the second adjustable expansion mandrel.

[0027] According to another aspect of the present invention, a method for forming a mono diameter wellbore casing is provided that includes positioning first and second adjustable expansion mandrels within a first expandable tubular member, supporting the first expandable tubular member and the first and second adjustable expansion mandrels within a borehole, lowering the first adjustable expansion mandrel out of the first expandable tubular member, increasing the outside dimension of the first adjustable expansion mandrel, displacing the first adjustable expansion mandrel upwardly relative to the first expandable tubular member to radially expand and plastically deform a lower portion of the first expandable tubular member, pressurizing an interior region of the first expandable tubular member above the first adjustable expansion mandrel during the radial expansion of the lower portion of the first expandable tubular member by the first adjustable expansion mandrel, displacing the first adjustable expansion mandrel and the second adjustable expansion mandrel downwardly relative to the first expandable tubular member, decreasing the outside dimension of the first adjustable expansion mandrel and increasing the outside dimension of the second adjustable expansion mandrel, displacing the second adjustable expansion mandrel upwardly relative to the first expandable tubular member to radially expand and plastically deform portions of the first expandable tubular member above the lower portion of the expandable tubular member, pressurizing an interior region of the first expandable tubular member above the second adjustable expansion mandrel during the radial expansion of the portions of the first expandable tubular member above the lower portion of the first expandable tubular member by the second adjustable expansion mandrel, positioning first and second adjustable expansion mandrels within a second expandable tubular member, supporting the first expandable tubular member and the first and second adjustable expansion mandrels within the borehole in overlapping relation to the first



expandable tubular member, lowering the first adjustable expansion mandrel out of the second expandable tubular member, increasing the outside dimension of the first adjustable expansion mandrel, displacing the first adjustable expansion mandrel upwardly relative to the second expandable tubular member to radially expand and plastically deform a lower portion of the second expandable tubular member, pressurizing an interior region of the second expandable tubular member above the first adjustable expansion mandrel during the radial expansion of the lower portion of the second expandable tubular member by the first adjustable expansion mandrel, displacing the first adjustable expansion mandrel and the second adjustable expansion mandrel downwardly relative to the second expandable tubular member, decreasing the outside dimension of the first adjustable expansion mandrel and increasing the outside dimension of the second adjustable expansion mandrel, displacing the second adjustable expansion mandrel upwardly relative to the second expandable tubular member to radially expand and plastically deform portions of the second expandable tubular member above the lower portion of the second expandable tubular member, and pressurizing an interior region of the second expandable tubular member above the second adjustable expansion mandrel during the radial expansion of the portions of the second expandable tubular member above the lower portion of the second expandable tubular member by the second adjustable expansion mandrel. The outside dimension of the first adjustable expansion mandrel is greater than the outside dimension of the second adjustable expansion mandrel.

[0028] According to another aspect of the present invention, an apparatus for radially expanding and plastically deforming an expandable tubular member is provided that includes a support member, a locking device coupled to the support member and releasably coupled to the expandable tubular member, an adjustable expansion mandrel adapted to be controllably expanded to a larger outside dimension for radial expansion and plastic deformation of the expandable tubular member or collapsed to a smaller outside dimension; and an actuator coupled to the locking member and the adjustable expansion mandrel adapted to displace the adjustable expansion mandrel upwardly through the expandable tubular member to radially expand and plastically deform the expandable tubular member.

[0029] According to another aspect of the present invention, a method for radially expanding and plastically deforming an expandable tubular member within a borehole is provided that includes supporting the expandable tubular member, an hydraulic actuator, and an adjustable expansion mandrel within the borehole, increasing the size of the adjustable expansion mandrel, displacing the adjustable expansion mandrel upwardly relative to the expandable tubular member using the hydraulic actuator to radially expand and plastically deform a portion of the expandable tubular member.

[0030] According to another aspect of the present invention, a method for forming a mono diameter wellbore casing within a borehole that includes a preexisting wellbore casing is provided that includes supporting the expandable tubular member, an hydraulic actuator, and an adjustable expansion mandrel within the borehole, increasing the size of the adjustable expansion mandrel, displacing the adjustable expansion mandrel upwardly relative to the expandable tubular member using the hydraulic

actuator to radially expand and plastically deform a portion of the expandable tubular member, and displacing the adjustable expansion mandrel upwardly relative to the expandable tubular member to radially expand and plastically deform the remaining portion of the expandable tubular member and a portion of the preexisting wellbore casing that overlaps with an end of the remaining portion of the expandable tubular member.

#### **Brief Description of the Drawings**

- [0031] Fig. 1 is a fragmentary cross-sectional illustration of the placement of an embodiment of an apparatus for radially expanding and plastically deforming a tubular member within a preexisting structure.
- [0032] Fig. 2 is a fragmentary cross-sectional illustration of apparatus of Fig. 1 after displacing the adjustable expansion mandrel and the float shoe downwardly out of the end of the expandable tubular member.
- [0033] Fig. 3 is a fragmentary cross-sectional illustration of the apparatus of Fig. 2 after expanding the adjustable expansion mandrel.
- [0034] Fig. 4 is a fragmentary cross-sectional illustration of the apparatus of Fig. 3 after displacing the adjustable expansion mandrel upwardly to radially expand and plastically deform the expandable tubular member.
- [0035] Fig. 5 is a fragmentary cross-sectional illustration of the apparatus of Fig. 4 after displacing the actuator, locking device, and tubular support member upwardly relative to the adjustable expansion mandrel and the expandable tubular member.
- [0036] Fig. 6 is a fragmentary cross-sectional illustration of the apparatus of Fig. 5 after displacing the adjustable expansion mandrel upwardly to radially expand and plastically deform the expandable tubular member.
- [0037] Fig. 6a is a fragmentary cross-sectional illustration of the apparatus of Fig. 6 that include one or more cup seals positioned above the adjustable expansion mandrel for defining an annular pressure chamber above the adjustable expansion mandrel.
- [0038] Fig. 7 is a fragmentary cross-sectional illustration of the placement of an embodiment of an apparatus for drilling a borehole and radially expanding and plastically deforming a tubular member within the drilled borehole.
- [0039] Fig. 8 is a fragmentary cross-sectional illustration of the apparatus of Fig. 7 after pivoting the drilling elements of the drilling member radially inwardly.
- [0040] Fig. 9 is a fragmentary cross-sectional illustration of apparatus of Fig. 8 after displacing the adjustable expansion mandrel and drilling member downwardly out of the end of the expandable tubular member.
- [0041] Fig. 10 is a fragmentary cross-sectional illustration of the apparatus of Fig. 9 after expanding the adjustable expansion mandrel.

- [0042] Fig. 11 is a fragmentary cross-sectional illustration of the apparatus of Fig. 10 after displacing the adjustable expansion mandrel upwardly to radially expand and plastically deform the expandable tubular member.
- [0043] Fig. 12 is a fragmentary cross-sectional illustration of the apparatus of Fig. 11 after displacing the actuator, locking device, and tubular support member upwardly relative to the adjustable expansion mandrel and the expandable tubular member.
- [0044] Fig. 13 is a fragmentary cross-sectional illustration of the apparatus of Fig. 12 after displacing the adjustable expansion mandrel upwardly to radially expand and plastically deform the expandable tubular member.
- [0045] Fig. 14 is a fragmentary cross-sectional illustration of the placement of an embodiment of an apparatus for radially expanding and plastically deforming a tubular member within a preexisting structure.
- [0046] Fig. 15 is a fragmentary cross-sectional illustration of the apparatus of Fig. 14 after displacing the lower adjustable expansion mandrel and float shoe downwardly out of the end of the expandable tubular member.
- [0047] Fig. 16 is a fragmentary cross-sectional illustration of the apparatus of Fig. 15 after expanding the lower adjustable expansion mandrel.
- [0048] Fig. 17 is a fragmentary cross-sectional illustration of the apparatus of Fig. 16 after displacing the lower adjustable expansion mandrel upwardly to radially expand and plastically deform the expandable tubular member.
- [0049] Fig. 18 is a fragmentary cross-sectional illustration of the apparatus of Fig. 17 after displacing the upper and lower adjustable expansion mandrels downwardly relative to the expandable tubular member.
- [0050] Fig. 19 is a fragmentary cross-sectional illustration of the apparatus of Fig. 18 after collapsing the lower adjustable expansion mandrel and expanding the upper adjustable expansion mandrel.
- [0051] Fig. 20 is a fragmentary cross-sectional illustration of the apparatus of Fig. 19 after displacing the upper adjustable expansion mandrel upwardly to radially expand and plastically deform the expandable tubular member.
- [0052] Fig. 21 is a fragmentary cross-sectional illustration of the apparatus of Fig. 20 after displacing the tubular support member, the locking device, and the actuator upwardly relative to the upper adjustable expansion mandrel and the expandable tubular member.
- [0053] Fig. 22 is a fragmentary cross-sectional illustration of the apparatus of Fig. 21 after displacing the upper adjustable expansion mandrel upwardly to radially expand and plastically deform the expandable tubular member.
- [0054] Fig. 23 is a fragmentary cross-sectional illustration of a mono diameter wellbore casing formed using one or more of the apparatus of Figs. 1-22.

- [0055] Figs. 24a-24k are fragmentary cross sectional illustrations of the placement of an exemplary embodiment of an apparatus for radially expanding and plastically deforming a tubular member within a wellbore that traverses a subterranean formation.
- [0056] Figs. 25a-25f are fragmentary cross sectional and perspective illustrations of the expansion cone assembly of the apparatus of Figs. 24a-24k.
- [0057] Fig. 25g is a perspective illustration of a float shoe locking dog.
- [0058] Fig. 25h is a fragmentary cross sectional illustration of the design and operation of the casing gripper locking dogs.
- [0059] Figs. 26a-26k are fragmentary cross sectional illustrations of the apparatus of Figs. 24a-24k after expanding the expansion cone assembly.
- [0060] Figs. 27a-27b are a fragmentary cross sectional and perspective illustrations of the expansion cone assembly of the apparatus of Figs. 26a-26k.
- [0061] Figs. 28a-28j are fragmentary cross sectional illustrations of the apparatus of Figs. 26a-26k during the upward displacement of the expansion cone assembly by the actuators to radially expand and plastically deform a portion of the casing.
- [0062] Figs. 29a-29m are fragmentary cross sectional illustrations of the apparatus of Figs. 28a-28j after the collapse of the expansion cone assembly.
- [0063] Figs. 30a-30c are fragmentary cross sectional illustrations of the process for collapsing the expansion cone assembly of the apparatus of Figs. 29a-29m.
- [0064] Figs. 31a-31n are fragmentary cross sectional illustrations of the apparatus of Figs. 29a-29m after the plastic deformation and radial expansion of the sealing sleeve and the disengagement of the casing from the locking dogs of the casing lock assembly.
- [0065] Figs. 32a-32k are fragmentary cross sectional illustrations of the apparatus of Figs. 31a-31n after setting down the apparatus onto the bottom of the wellbore to open the bypass valve in the shoe and expand the expansion cone assembly.
- [0066] Figs. 33a-33p are fragmentary cross sectional illustrations of the apparatus of Figs. 32a-32k during the radial expansion and plastic deformation of the casing.
- [0067] Figs. 34a-34l are fragmentary cross sectional illustrations of the apparatus of Figs. 33a-33p during the radial expansion and plastic deformation of a portion of the casing that overlaps within a preexisting wellbore casing within the wellbore.
- [0068] Figs. 35a-35l are fragmentary cross sectional illustrations of the apparatus of Figs. 28a-28j during the emergency collapse of the expansion cone assembly.
- [0069] Figs. 36a-36b are fragmentary cross sectional illustrations of several exemplary embodiments of the operation of the pressure balance piston.

#### Detailed Description of the Illustrative Embodiments

- [0070] Referring to Fig. 1, an exemplary embodiment of an apparatus 10 for radially expanding and plastically deforming a tubular member 12 includes a tubular support member 14 that extends into

the tubular member that is coupled to an end of a locking device 16 for controllably engaging the tubular member. Another end of the locking device 16 is coupled to a tubular support member 18 that is coupled to an end of an actuator 20. Another end of the actuator 20 is coupled to a tubular support member 22 that is coupled to an end of an adjustable expansion mandrel 24 for radially expanding and plastically deforming the tubular member 12. Another end of the adjustable expansion mandrel 24 is coupled to a tubular support member 26 that is coupled to an end of a float shoe 28 that mates with and is at least partially received within a lower end of the tubular member 12. In an exemplary embodiment, the locking device 16, the tubular support member 18, the actuator 20, the tubular support member 22, the adjustable expansion mandrel 24, and the tubular support member 26 are positioned within the tubular member 12.

[0071] In an exemplary embodiment, the tubular member 12 includes one or more solid and/or slotted tubular members, and one or more of the solid and/or slotted tubular members include resilient sealing members coupled to the exterior surfaces of the solid and/or slotted tubular members for engaging the wellbore 30 and/or one or more preexisting wellbore casings coupled to the wellbore. In an exemplary embodiment, the tubular support members, 14, 18, 22, and 26 define corresponding passages, that may or may not be valveable, for conveying fluidic materials into and/or through the apparatus 10.

[0072] In an exemplary embodiment, the locking device 16 includes one or more conventional controllable locking devices such as, for example, slips and/or dogs for controllably engaging the tubular member 12. In an exemplary embodiment, the locking device 16 is controlled by injecting fluidic materials into the locking device.

[0073] In an exemplary embodiment, the actuator 20 is a conventional actuator that is adapted to displace the adjustable expansion mandrel 24 and float shoe 28 upwardly or downwardly relative to the actuator.

[0074] In an exemplary embodiment, the adjustable expansion mandrel 24 is a conventional adjustable expansion mandrel that may be expanded to a larger outside dimension or collapsed to a smaller outside dimension and includes external surfaces for engaging the tubular member 12 to thereby radially expand and plastically deform the tubular member when the adjustable expansion mandrel is expanded to the larger outside dimension. In an alternative embodiment, the adjustable expansion mandrel 24 may include a rotary adjustable expansion device such as, for example, the commercially available rotary expansion devices of Weatherford International, Inc. In several alternative embodiments, the cross sectional profile of the adjustable expansion mandrel 24 for radial expansion operations may, for example, be an n-sided shape, where n may vary from 2 to infinity, and the side shapes may include straight line segments, arcuate segments, parabolic segments, and/or hyperbolic segments. In several alternative embodiments, the cross sectional profile of the adjustable expansion mandrel 24 may, for example, be circular, oval, elliptical, and/or multifaceted.

[0075] In an exemplary embodiment, the float shoe 28 is a conventional float shoe.

[0076] In an exemplary embodiment, the apparatus 10 is positioned within a preexisting structure 30 such as, for example, a wellbore that traverses a subterranean formation 32. The wellbore 30 may have any orientation from vertical to horizontal. In several exemplary embodiments, the wellbore 30 may include one or more preexisting solid and/or slotted and/or perforated wellbore casings that may or may not overlap with one another within the wellbore.

[0077] As illustrated in Fig. 2, the adjustable expansion mandrel 24 and the float shoe 28 are then displaced downwardly out of the tubular member 12 by the actuator 20. During the downward displacement of the adjustable expansion mandrel 24 and the float shoe 28 out of the tubular member 12, the tubular member is maintained in a stationary position relative to the tubular support member 14 by the locking device 16.

[0078] As illustrated in Fig. 3, the adjustable expansion mandrel 24 is then expanded to the larger dimension. In several alternative embodiments, the adjustable expansion mandrel 24 may be expanded to the larger dimension by, for example, injecting a fluidic material into the adjustable expansion mandrel and/or by impacting the float shoe 28 on the bottom of the wellbore 30. After expanding the adjustable expansion mandrel 24 to the larger dimension, expansion surfaces 24a are defined on the adjustable expansion mandrel that may include, for example, conical, spherical, elliptical, and/or hyperbolic surfaces for radially expanding and plastically deforming the tubular member 12. In an exemplary embodiment, the expansion surfaces 24a also include means for lubricating the interface between the expansion surfaces and the tubular member 12 during the radial expansion and plastic deformation of the tubular member.

[0079] As illustrated in Fig. 4, the adjustable expansion mandrel 24 is then displaced upwardly by the actuator 20 to thereby radially expand and plastically deform a portion of the tubular member 12. In an exemplary embodiment, during the upward displacement of the adjustable expansion mandrel 24, the tubular member 12 is maintained in a stationary position relative to the tubular support member 14 by the locking device 16. In an exemplary embodiment, the tubular member 12 is radially expanded and plastically deformed into engagement with the wellbore 30 and/or one or more preexisting wellbore casings coupled to the wellbore 30. In an exemplary embodiment, the interface between the expansion surfaces 24a of the adjustable expansion mandrel 24 and the tubular member 12 is not fluid tight in order to facilitate the lubrication of the interface between the expansion surface of the adjustable expansion mandrel and the tubular member.

[0080] As illustrated in Fig. 5, the locking device 16 is then disengaged from the tubular member 12, and the tubular member 12 is supported by the adjustable expansion mandrel 24. The tubular support member 14, the locking device 16, the tubular support member 18, and the actuator 20 are then displaced upwardly relative to the adjustable expansion mandrel 24.

[0081] As illustrated in Fig. 6, the locking device 16 then engages the tubular member 12 to maintain the tubular member in a stationary position relative to the tubular support member 14, and the

adjustable expansion mandrel 24 is displaced upwardly relative by the actuator 20 to radially expand and plastically deform another portion of the tubular member.

[0082] In an exemplary embodiment, the operations of Figs. 5 and 6 are then repeated until the entire length of the tubular member 12 is radially expanded and plastically deformed by the adjustable expansion mandrel 24. In several alternative embodiments, the adjustable expansion mandrel 24 may be collapsed to the smaller dimension prior to the further, or complete, radial expansion and plastic deformation of the tubular member 12.

[0083] In several alternative embodiments, as illustrated in Fig. 6a, the apparatus 10 further includes one or more cup seals 34 that are coupled to the tubular support member 22 and engage the tubular member 12 to define an annular chamber 36 above the adjustable expansion cone 24, and fluidic materials 38 are injected into the tubular member 12 through passages defined within the tubular support member 14, the locking device 16, the tubular support member 18, the actuator 20, the tubular support member 22, the adjustable expansion mandrel 24, the tubular support member 26, and the float shoe 28 to thereby pressurize the annular chamber 36. In this manner, the resulting pressure differential created across the cup seals 34 causes the cup seals to pull the adjustable expansion mandrel 24 upwardly to radially expand and plastically deform the tubular member 12. In several alternative embodiments, the injection of the fluidic material 38 into the tubular member 12 is provided in combination with, or in the alternative to, the upward displacement of the expansion mandrel 24 by the actuator 20. In several alternative embodiments, during the injection of the fluidic material 38, the locking device 16 is disengaged from the tubular member 12.

[0084] Referring to Fig. 7, an alternative embodiment of an apparatus 100 for radially expanding and plastically deforming the tubular member 12 is substantially identical in design and operation to the apparatus 10 with the addition of one or more conventional drilling members 40a-40b that are pivotally coupled to the float shoe 28. During operation of the apparatus 100, the drilling members 40a-40b may be operated to extend the length and/or diameter of the wellbore 30, for example, by rotating the apparatus and/or by injecting fluidic materials into the apparatus to operate the drilling members.

[0085] As illustrated in Fig. 7, in an exemplary embodiment, the apparatus 100 is initially positioned within the preexisting structure 30.

[0086] As illustrated in Fig. 8, in an exemplary embodiment, the drilling members 40a-40b may then be pivoted inwardly in a conventional manner.

[0087] As illustrated in Fig. 9 the adjustable expansion mandrel 24, the float shoe 28, and the drilling members 40a-40b are then displaced downwardly out of the tubular member 12 by the actuator 20. During the downward displacement of the adjustable expansion mandrel 24, the float shoe 28, and the drilling members 40a-40b out of the tubular member 12, the tubular member is maintained in a stationary position relative to the tubular support member 14 by the locking device 16.

[0088] As illustrated in Fig. 10, the adjustable expansion mandrel 24 is then expanded to the larger dimension. In several alternative embodiments, the adjustable expansion mandrel 24 may be expanded

to the larger dimension by, for example, injecting a fluidic material into the adjustable expansion mandrel and/or by impacting the drilling members 40a-40b on the bottom of the wellbore 30. After expanding the adjustable expansion mandrel 24 to the larger dimension, expansion surfaces 24a are defined on the adjustable expansion mandrel that may include, for example, conical, spherical, elliptical, and/or hyperbolic surfaces for radially expanding and plastically deforming the tubular member 12. In an exemplary embodiment, the expansion surfaces 24a also include means for lubricating the interface between the expansion surfaces and the tubular member 12 during the radial expansion and plastic deformation of the tubular member.

[0089] As illustrated in Fig. 11, the adjustable expansion mandrel 24 is then displaced upwardly by the actuator 20 to thereby radially expand and plastically deform a portion of the tubular member 12. In an exemplary embodiment, during the upward displacement of the adjustable expansion mandrel 24, the tubular member 12 is maintained in a stationary position relative to the tubular support member 14 by the locking device 16. In an exemplary embodiment, the tubular member 12 is radially expanded and plastically deformed into engagement with the wellbore 30 and/or one or more preexisting wellbore casings coupled to the wellbore 30. In an exemplary embodiment, the interface between the expansion surfaces 24a of the adjustable expansion mandrel 24 and the tubular member 12 is not fluid tight in order to facilitate the lubrication of the interface between the expansion surface of the adjustable expansion mandrel and the tubular member.

[0090] As illustrated in Fig. 12, the locking device 16 is then disengaged from the tubular member 12, and the tubular member 12 is supported by the adjustable expansion mandrel 24. The tubular support member 14, the locking device 16, the tubular support member 18, and the actuator 20 are then displaced upwardly relative to the adjustable expansion mandrel 24.

[0091] As illustrated in Fig. 13, the locking device 16 then engages the tubular member 12 to maintain the tubular member in a stationary position relative to the tubular support member 14, and the adjustable expansion mandrel 24 is displaced upwardly relative by the actuator 20 to radially expand and plastically deform another portion of the tubular member.

[0092] In an exemplary embodiment, the operations of Figs. 12 and 13 are then repeated until the entire length of the tubular member 12 is radially expanded and plastically deformed by the adjustable expansion mandrel 24. In several alternative embodiments, the adjustable expansion mandrel 24 may be collapsed to the smaller dimension prior to the further, or complete, radial expansion and plastic deformation of the tubular member 12.

[0093] Referring to Fig. 14, an alternative embodiment of an apparatus 200 for radially expanding and plastically deforming the tubular member 12 is substantially identical in design and operation to the apparatus 10 except that the adjustable expansion mandrel 24 has been replaced by an upper adjustable expansion mandrel 202 that is coupled to the tubular support member 22, a tubular support member 204 that is coupled to the upper adjustable expansion mandrel, and a lower adjustable expansion mandrel 206 that is coupled to the tubular support member 204 and the tubular support member 26.



[0094] The upper and lower adjustable expansion mandrels, 202 and 206, may be conventional adjustable expansion mandrels that may be expanded to larger outside dimensions or collapsed to smaller outside dimensions and include external surfaces for engaging the tubular member 12 to thereby radially expand and plastically deform the tubular member when the adjustable expansion mandrels are expanded to the larger outside dimensions. In an alternative embodiment, the upper and/or lower adjustable expansion mandrels, 202 and 206, may include rotary adjustable expansion devices such as, for example, the commercially available rotary expansion devices of Weatherford International, Inc. In an exemplary embodiment, the tubular support member 204 defines a passage, that may, or may not, be valveable, for conveying fluidic materials into and/or through the apparatus 200. In several alternative embodiments, the cross sectional profiles of the adjustable expansion mandrels, 202 and 206, for radial expansion operations may, for example, be n-sided shapes, where n may vary from 2 to infinity, and the side shapes may include straight line segments, arcuate segments, parabolic segments, and/or hyperbolic segments. In several alternative embodiments, the cross sectional profiles of the adjustable expansion mandrels, 202 and 206, may, for example, be circular, oval, elliptical, and/or multifaceted.

[0095] As illustrated in Fig. 14, in an exemplary embodiment, the apparatus 200 is initially positioned within the preexisting structure 30.

[0096] As illustrated in Fig. 15, the lower adjustable expansion mandrel 206 and the float shoe 28 are then displaced downwardly out of the tubular member 12 by the actuator 20. During the downward displacement of the lower adjustable expansion mandrel 206 and the float shoe 28 out of the tubular member 12, the tubular member is maintained in a stationary position relative to the tubular support member 14 by the locking device 16.

[0097] As illustrated in Fig. 16, the lower adjustable expansion mandrel 206 is then expanded to the larger dimension. In several alternative embodiments, the lower adjustable expansion mandrel 206 may be expanded to the larger dimension by; for example, injecting a fluidic material into the lower adjustable expansion mandrel and/or by impacting the float shoe 28 on the bottom of the wellbore 30. After expanding the lower adjustable expansion mandrel 206 to the larger dimension, expansion surfaces 206a are defined on the lower adjustable expansion mandrel that may include, for example, conical, spherical, elliptical, and/or hyperbolic surfaces for radially expanding and plastically deforming the tubular member 12. In an exemplary embodiment, the expansion surfaces 206a also include means for lubricating the interface between the expansion surfaces and the tubular member 12 during the radial expansion and plastic deformation of the tubular member.

[0098] As illustrated in Fig. 17, the lower adjustable expansion mandrel 206 is then displaced upwardly by the actuator 20 to thereby radially expand and plastically deform a portion 12a of the tubular member 12. In an exemplary embodiment, during the upward displacement of the lower adjustable expansion mandrel 206, the tubular member 12 is maintained in a stationary position relative to the tubular support member 14 by the locking device 16. In an exemplary embodiment, the tubular

member 12 is radially expanded and plastically deformed into engagement with the wellbore 30 and/or one or more preexisting wellbore casings coupled to the wellbore 30. In an exemplary embodiment, the interface between the expansion surfaces 206a of the lower adjustable expansion mandrel 206 and the tubular member 12 is not fluid tight in order to facilitate the lubrication of the interface between the expansion surface of the lower adjustable expansion mandrel and the tubular member. In an exemplary embodiment, the expansion surfaces 206a also include means for lubricating the interface between the expansion surfaces and the tubular member 12 during the radial expansion and plastic deformation of the tubular member.

[0099] As illustrated in Fig. 18, the upper and lower adjustable expansion mandrels, 202 and 206, and the float shoe 28 are then displaced downwardly by the actuator 20. During the downward displacement of the upper and lower adjustable expansion mandrels, 202 and 206, and the float shoe 28, the tubular member is maintained in a stationary position relative to the tubular support member 14 by the locking device 16.

[0100] As illustrated in Fig. 19, the upper adjustable expansion mandrel 202 is then expanded to the larger dimension and the lower adjustable expansion mandrel 206 is collapsed to the smaller dimension. In an exemplary embodiment, the larger dimension of the upper adjustable expansion mandrel 202 is less than the larger dimension of the lower adjustable expansion mandrel 206. In several alternative embodiments, the upper adjustable expansion mandrel 202 may be expanded to the larger dimension and the lower adjustable expansion mandrel 206 may be collapsed to the smaller dimension by, for example, injecting fluidic material into the upper and/or adjustable expansion mandrel and/or by impacting the float shoe 28 on the bottom of the wellbore 30. After expanding the upper adjustable expansion mandrel 202 to the larger dimension, expansion surfaces 202a are defined on the upper adjustable expansion mandrel that may include, for example, conical, spherical, elliptical, and/or hyperbolic surfaces for radially expanding and plastically deforming the tubular member 12. In an exemplary embodiment, the expansion surfaces 202a also include means for lubricating the interface between the expansion surfaces and the tubular member 12 during the radial expansion and plastic deformation of the tubular member.

[0101] As illustrated in Fig. 20, the upper adjustable expansion mandrel 202 is then displaced upwardly by the actuator 20 to thereby radially expand and plastically deform a portion 12b of the tubular member 12 above the portion 12a of the tubular member. In an exemplary embodiment, the inside diameter of the radially expanded and plastically deformed portion 12a of the tubular member 12 is greater than the inside diameter of the radially expanded and plastically deformed portion 12b of the tubular member. In an exemplary embodiment, during the upward displacement of the upper adjustable expansion mandrel 202, the tubular member 12 is maintained in a stationary position relative to the tubular support member 14 by the locking device 16. In an exemplary embodiment, the tubular member 12 is radially expanded and plastically deformed into engagement with the wellbore 30 and/or one or more preexisting wellbore casings coupled to the wellbore 30. In an exemplary embodiment, the

interface between the expansion surfaces 202a of the upper adjustable expansion mandrel 202 and the tubular member 12 is not fluid tight in order to facilitate the lubrication of the interface between the expansion surface of the upper adjustable expansion mandrel and the tubular member.

[0102] As illustrated in Fig. 21, the locking device 16 is then disengaged from the tubular member 12, and the tubular member 12 is supported by the upper adjustable expansion mandrel 202. The tubular support member 14, the locking device 16, the tubular support member 18, and the actuator 20 are then displaced upwardly relative to the upper adjustable expansion mandrel 202 and the tubular member 12.

[0103] As illustrated in Fig. 22, the locking device 16 then engages the tubular member 12 to maintain the tubular member in a stationary position relative to the tubular support member 14, and the upper adjustable expansion mandrel 202 is displaced upwardly relative by the actuator 20 to radially expand and plastically deform the portion 12b of the tubular member.

[0104] In an exemplary embodiment, the operations of Figs. 21 and 22 are then repeated until the remaining length of the portion 12b of the tubular member 12 is radially expanded and plastically deformed by the upper adjustable expansion mandrel 202. In several alternative embodiments, the upper adjustable expansion mandrel 202 may be collapsed to the smaller dimension prior to the further, or complete, radial expansion and plastic deformation of the tubular member 12.

[0105] Referring to Fig. 23, in an exemplary embodiment, the method and apparatus of one or more of Figs. 1-22 are repeated to provide a mono diameter wellbore casing 300 within a borehole 302 that traverses a subterranean formation 304 by successively overlapping and radially expanding and plastically deforming wellbore casing 306a-306d within the wellbore. In this manner, a wellbore casing 300 is provided that defines an interior passage having a substantially constant cross sectional area throughout its length. In several alternative embodiments, the cross section of the wellbore casing 300 may be, for example, square, rectangular, elliptical, oval, circular and/or faceted.

[0106] Referring to Figs. 24a-24k, an exemplary embodiment of an apparatus 400 for radially expanding and plastically deforming a tubular member includes a tubular support member 402 that defines a longitudinal passage 402a that is threadably coupled to and received within an end of a tool joint adaptor 404 that defines a longitudinal passage 404a and radial passages 404b and 404c.

[0107] The other end of the tool joint adaptor 404 receives and is threadably coupled to an end of a gripper upper mandrel 406 that defines a longitudinal passage 406a, external radial mounting holes, 406b and 406c, an external annular recess 406d, an external annular recess 406e, hydraulic port 406f, an internal annular recess 406g, hydraulic port 406h, external radial mounting holes, 406i and 406j, and includes a flange 406k, and a flange 406l. Torsional locking pins, 408a and 408b, are coupled to the external radial mounting holes, 406b and 406c, respectively, of the gripper upper mandrel 406 and received within the radial passages, 404b and 404c, respectively, of the tool joint adaptor 404.

[0108] A spring retainer sleeve 410 that includes a flange 410a receives and is threadably coupled to the gripper upper mandrel 406 between an end face of the tool joint adaptor 404 and the flange 406k

of the gripper upper mandrel. A bypass valve body 412 receives and is movably coupled to the gripper upper mandrel 406 that defines radial passages, 412a and 412b, and an internal annular recess 412c includes a flange 412d.

[0109] An end of a spring cover 414 receives and is movably coupled to the spring retainer sleeve 410 that defines an internal annular recess 414a. The other end of the spring cover 414 receives and is threadably coupled to an end of the bypass valve body 412. A spring guide 416, a spring 418, and a spring guide 420 are positioned within an annular chamber 422 defined between the spring cover 414 and the flange 406k of the gripper upper mandrel 406. Furthermore, an end of the spring guide 416 abuts an end face of the spring retainer sleeve 410.

[0110] Casing gripper locking dogs, 424a and 424b, are received and pivotally mounted within the radial passages, 412a and 412b, respectively, of the bypass valve body 412. An end of each of the casing gripper locking dogs, 424a and 424b, engage and are received within the outer annular recess 406d of the gripper upper mandrel 406. An end of a debris trap 426 receives and is threadably coupled to an end of the bypass valve body 412, and the other end of the debris trap receives and is movably coupled to the flange 406l of the gripper upper mandrel 406.

[0111] An end of a gripper body 428 receives and is threadably coupled to an end of the gripper upper mandrel 406 that defines a longitudinal passage 428a, radial passages, 428b and 428c, radial slip mounting passages, 428d-428m, and radial passages, 428n and 428o, includes a flange 428p.

[0112] Hydraulic slip pistons 432a-432j are movably mounted with the radial slip mounting passages 428d-428m, respectively, for movement in the radial direction. Retainers 434a-434j are coupled to the exterior of the flange 428p of the gripper body 428 for limiting the outward radial movement of the hydraulic slip pistons 432a-432j, respectively, and springs 436a-436j are positioned within the radial slip mounting passages, 428d-428m, respectively, of the gripper-body between the hydraulic slip pistons, 432a-432j, and the retainers, 434a-434j, respectively. During operation of the apparatus 400, pressurization of the radial slip mounting passages, 428d-428m, displaces the hydraulic slip pistons, 432a-432j, respectively, radially outwardly and compresses the springs, 436a-436j, respectively, and during depressurization of the radial slip mounting passages, 428d-428m, springs, 436a-436j, respectively, displace the hydraulic slip pistons, 432a-432j, inwardly. In an exemplary embodiment, displacement of the hydraulic slip pistons 432a-432j radially outwardly permits at least portions of the hydraulic slip pistons to engage and grip an outer tubular member.

[0113] Torsional locking pins, 438a and 438b, are coupled to the external radial mounting holes, 406i and 406j, respectively, of the gripper upper mandrel 406 and received within the radial passages, 428b and 428c, respectively, of the gripper body 428.

[0114] An end of a gripper body 440 receives and is threadably coupled to an end of the gripper body 428 that defines a longitudinal passage 440a, radial passages, 440b and 440c, radial slip mounting passages, 440d-440m, and radial passages, 440n and 440o, includes a flange 440p.

[0115] Hydraulic slip pistons 442a-442j are movably mounted with the radial slip mounting passages 440d-440m, respectively, for movement in the radial direction. Retainers 444a-444j are coupled to the exterior of the flange 440p of the gripper body 440 for limiting the outward radial movement of the hydraulic slip pistons 442a-442j, respectively, and springs 446a-446j are positioned within the radial slip mounting passages, 440d-440m, respectively, of the gripper body between the hydraulic slip pistons, 442a-442j, and the retainers, 444a-444j, respectively. During operation of the apparatus 400, pressurization of the radial slip mounting passages, 440d-440m, displaces the hydraulic slip pistons, 442a-442j, respectively, radially outwardly and compresses the springs, 446a-446j, respectively, and during depressurization of the radial slip mounting passages, 440d-440m, the springs, 446a-446j, respectively, displace the hydraulic slip pistons, 442a-442j, radially inward. In an exemplary embodiment, displacement of the hydraulic slip pistons 442a-442j radially outwardly permits at least portions of the hydraulic slip pistons to engage and grip an outer tubular member.

[0116] Torsional locking pins, 448a and 448b, are coupled to the external radial mounting holes, 428n and 428o, respectively, of the gripper body 428 and received within the radial passages, 440b and 440c, respectively, of the gripper body 440.

[0117] An end of a tool joint adaptor 450 that defines a longitudinal passage 450a, radial passages, 450b and 450c, and an inner annular recess 450d, receives and is threadably coupled to an end of the gripper body 440. Torsional locking pins, 452a and 452b, are coupled to the external radial mounting holes, 440n and 440o, respectively, of the gripper body 428 and received within the radial passages, 450b and 450c, respectively, of the tool joint adaptor 450.

[0118] A bypass tube 454 that defines a longitudinal passage 454a is received within the longitudinal passages, 406a, 428a, 440a, and 450a, of the gripper upper mandrel 406, the gripper body 428, the gripper body 440, and the tool joint adaptor 450, respectively, is coupled to the recess 406g of the gripper upper mandrel at one end and is coupled to the recess 450d of the tool joint adaptor at the other end.

[0119] An end of a cross over adaptor 456 that defines a longitudinal passage 456a receives and is threadably coupled to an end of the tool joint adaptor 450. The other end of the cross over adaptor 456 is received within and is coupled to an end of a tool joint adaptor 458 that defines a longitudinal passage 458a and external radial mounting holes, 458b and 458c.

[0120] An end of a positive casing locking body 460 that defines a tapered longitudinal passage 460a and radial passages, 460b and 460c, receives and is threadably coupled to the other end of the tool joint adaptor 458. Torsional locking pins, 462a and 462b, are coupled to the external radial mounting holes, 458b and 458c, respectively, of the tool joint adaptor 458 and received within the radial passages, 460b and 460c, respectively, of the positive casing locking body 460.

[0121] An end of a positive casing locking dog 464 mates with, is received within, and is coupled to the other end of the positive casing locking body 460 that includes internal flanges, 464a and 464b, and an external flange 464c. In an exemplary embodiment, the external flange 464c of the positive

casing locking dog 464 includes an ribbed external surface 464d that engages and locks onto a ribbed internal surface 466a of a positive casing locking collar 466.

[0122] One end of the positive casing locking collar 466 is threadably coupled to a casing 468 and the other end of the positive casing locking collar is threadably coupled to a casing 470 that defines radial mounting holes, 470a and 470b, at a lower end thereof. In this manner, the casings, 468 and 470, are also engaged by and locked onto the positive casing locking dog 464.

[0123] The other end of the positive casing locking dog 464 mates with, is received within, and is coupled to an end of a positive casing locking body 472 that defines a tapered longitudinal passage 472a and radial passages, 472b and 472c. The other end of the positive casing locking body 472 receives, mates with, and is coupled to an end of a casing lock barrel adaptor 474 that defines external radial mounting holes, 474a and 474b, and external radial mounting holes, 474c and 474d. Torsional locking pins, 475a and 475b, are coupled to the external radial mounting holes, 474a and 474b, respectively, of the casing lock barrel adaptor 474 and received within the radial passages, 472b and 472c, respectively, of the positive casing locking body 472.

[0124] An end of a positive casing lock releasing mandrel 476 that defines a longitudinal passage 476a, an external annular recess 476b, an external annular recess 476c, an external annular recess 476d, and an external annular recessed end portion 476e, is received within and movably coupled to an end of the tool joint adaptor 458. The middle portion of the positive casing lock releasing mandrel 476 is received within and mates with the internal flanges, 464a and 464b, of the positive casing locking dogs 464. The other end of the positive casing lock releasing mandrel 476 is received within and is movably coupled to the end of the casing lock barrel adaptor 474, and the external annular recessed portion 476e of the positive casing lock releasing mandrel is threadably coupled to and received within an end of a positive casing lock lower mandrel 478 that defines a longitudinal passage 478a, external radial mounting holes, 478b and 478c, and an external annular recessed end portion 478d.

[0125] A shear pin ring 480 that defines radial passages, 480a and 480b, receives and mates with the positive casing lock lower mandrel 478. Shear pins, 482a and 482b, are coupled to the external radial mounting holes, 478b and 478c, respectively, of the positive casing lock lower mandrel 478 and are received within the radial passages, 480a and 480b, respectively, of the shear pin ring 480.

[0126] An end of an actuator barrel 484 that defines a longitudinal passage 484a, radial passages, 484b and 484c, and radial passages, 484d and 484e, is threadably coupled to an end of the casing lock barrel adaptor 474. Torsional locking pins, 486a and 486b, are coupled to the external radial mounting holes, 474c and 474d, respectively, of the casing lock barrel adaptor and are received within the radial passages, 484b and 484c, respectively, of the actuator barrel.

[0127] The other end of the actuator barrel 484 is threadably coupled to an end of a barrel connector 486 that defines an internal annular recess 486a, external radial mounting holes, 486b and 486c, radial passages, 486d and 486e, and external radial mounting holes, 486f and 486g. A sealing cartridge 488 is received within and coupled to the internal annular recess 486a of the barrel connector

486 for fluidically sealing the interface between the barrel connector and the sealing cartridge. Torsional locking pins, 490a and 490b, are coupled to and mounted within the external radial mounting holes, 486b and 486c, respectively, of the barrel connector 486 and received within the radial passages, 484d and 484e, of the actuator barrel 484.

[0128] The other end of the barrel connector 486 is threadably coupled to an end of an actuator barrel 492 that defines a longitudinal passage 492a, radial passages, 492b and 492c, and radial passages, 492d and 492e. Torsional locking pins, 494a and 494b, are coupled to and mounted within the external radial mounting holes, 486f and 486g, respectively, of the barrel connector 486 and received within the radial passages, 492b and 492c, of the actuator barrel 492. The other end of the actuator barrel 492 is threadably coupled to an end of a barrel connector 496 that defines an internal annular recess 496a, external radial mounting holes, 496b and 496c, radial passages, 496d and 496e, and external radial mounting holes, 496f and 496g. A sealing cartridge 498 is received within and coupled to the internal annular recess 496a of the barrel connector 496 for fluidically sealing the interface between the barrel connector and the sealing cartridge. Torsional locking pins, 500a and 500b, are coupled to and mounted within the external radial mounting holes, 496b and 496c, respectively, of the barrel connector 496 and received within the radial passages, 492d and 492e, of the actuator barrel 492.

[0129] The end of the barrel connector 496 is threadably coupled to an end of an actuator barrel 502 that defines a longitudinal passage 502a, radial passages, 502b and 502c, and radial passages, 502d and 502e. Torsional locking pins, 504a and 504b, are coupled to and mounted within the external radial mounting holes, 496f and 496g, respectively, of the barrel connector 496 and received within the radial passages, 502b and 502c, of the actuator barrel 502. The other end of the actuator barrel 502 is threadably coupled to an end of a barrel connector 506 that defines an internal annular recess 506a, external radial mounting holes, 506b and 506c, radial passages, 506d and 506e, and external radial mounting holes, 506f and 506g. Torsional locking pins, 508a and 508b, are coupled to and mounted within the external radial mounting holes, 506b and 506c, respectively, of the barrel connector 506 and received within the radial passages, 502d and 502e, of the actuator barrel 502. A sealing cartridge 510 is received within and coupled to the internal annular recess 506a of the barrel connector 506 for fluidically sealing the interface between the barrel connector and the sealing cartridge.

[0130] The other end of the barrel connector 506 is threadably coupled to an end of an actuator barrel 512 that defines a longitudinal passage 512a, radial passages, 512b and 512c, and radial passages, 512d and 512e. Torsional locking pins, 514a and 514b, are coupled to and mounted within the external radial mounting holes, 506f and 506g, respectively, of the barrel connector 506 and received within the radial passages, 512b and 512c, of the actuator barrel 512. The other end of the actuator barrel 512 is threadably coupled to an end of a lower stop 516 that defines an internal annular recess 516a, external radial mounting holes, 516b and 516c, and an internal annular recess 516d that includes one or more circumferentially spaced apart locking teeth 516e at one end and one or more circumferentially spaced apart locking teeth 516f at the other end. A sealing cartridge 518 is received within and coupled to the

internal annular recess 516a of the barrel connector 516 for fluidically sealing the interface between the barrel connector and the sealing cartridge. Torsional locking pins, 520a and 520b, are coupled to and mounted within the external radial mounting holes, 516b and 516c, respectively, of the barrel connector 516 and received within the radial passages, 512d and 512e, of the actuator barrel 512.

[0131] A connector tube 522 that defines a longitudinal passage 522a is received within and sealingly and movably engages the interior surface of the sealing cartridge 488 mounted within the annular recess 486a of the barrel connector 486. In this manner, during longitudinal displacement of the connector tube 522 relative to the barrel connector 486, a fluidic seal is maintained between the exterior surface of the connector tube and the interior surface of the barrel connector. An end of the connector tube 522 is received within and is threadably coupled to an end of dart/ball guide 524 that defines a tapered passage 524a at the other end.

[0132] The other end of the connector tube 522 is received within and threadably coupled to an end of a piston 526 that defines a longitudinal passage 526a and radial passages, 526b and 526c, that includes a flange 526d at one end. A sealing cartridge 528 is mounted onto and sealingly coupled to the exterior of the piston 526 proximate the flange 526d. The sealing cartridge 528 also mates with and sealingly engages the interior surface of the actuator barrel 492. In this manner, during longitudinal displacement of the piston 526 relative to the actuator barrel 492, a fluidic seal is maintained between the exterior surface of the piston and the interior surface of the actuator barrel.

[0133] The other end of the piston 526 receives and is threadably coupled to an end of a connector tube 529 that defines a longitudinal passage 528a. The connector tube 529 is received within and sealingly and movably engages the interior surface of the sealing cartridge 498 mounted within the annular recess 496a of the barrel connector 496. In this manner, during longitudinal displacement of the connector tube 529 relative to the barrel connector 496, a fluidic seal is maintained between the exterior surface of the connector tube and the interior surface of the barrel connector.

[0134] The other end of the connector tube 529 is received within and threadably coupled to an end of a piston 530 that defines a longitudinal passage 530a and radial passages, 530b and 530c, that includes a flange 530d at one end. A sealing cartridge 532 is mounted onto and sealingly coupled to the exterior of the piston 530 proximate the flange 530d. The sealing cartridge 532 also mates with and sealingly engages the interior surface of the actuator barrel 502. In this manner, during longitudinal displacement of the piston 530 relative to the actuator barrel 502, a fluidic seal is maintained between the exterior surface of the piston and the interior surface of the actuator barrel.

[0135] The other end of the piston 530 receives and is threadably coupled to an end of a connector tube 534 that defines a longitudinal passage 534a. The connector tube 534 is received within and sealingly and movably engages the interior surface of the sealing cartridge 510 mounted within the annular recess 506a of the barrel connector 506. In this manner, during longitudinal displacement of the connector tube 534 relative to the barrel connector 506, a fluidic seal is maintained between the exterior surface of the connector tube and the interior surface of the barrel connector.



[0136] The other end of the connector tube 534 is received within and threadably coupled to an end of a piston 536 that defines a longitudinal passage 536a, radial passages, 536b and 536c, and external radial mounting holes, 536d and 536e, that includes a flange 536f at one end. A sealing cartridge 538 is mounted onto and sealingly coupled to the exterior of the piston 536 proximate the flange 536d. The sealing cartridge 538 also mates with and sealingly engages the interior surface of the actuator barrel 512. In this manner, during longitudinal displacement of the piston 536 relative to the actuator barrel 512, a fluidic seal is maintained between the exterior surface of the piston and the interior surface of the actuator barrel.

[0137] The other end of the piston 536 is received within and threadably coupled to an end of a lock nut 540 that defines radial passages, 540a and 540b, and includes one or more circumferentially spaced apart locking teeth 540c at the other end for engaging the circumferentially spaced apart locking teeth 516e of the lower stop 516.

[0138] A threaded bushing 542 is received within and threadably coupled to the circumferentially spaced apart locking teeth 540c of the lock nut 540. An end of a connector tube 544 that defines a longitudinal passage 544a is received within and is threadably coupled to the threaded bushing 542. A sealing sleeve 546 is received within and is threadably coupled to adjacent ends of the piston 536 and the connector tube 544 for fluidically sealing the interface between the end of the piston and the end of the connector tube. Torsional locking pins, 548a and 548b, are mounted within and coupled to the external radial mounting holes, 536d and 536e, respectively, of the piston 536 that are received within the radial passages, 540a and 540b, of the stop nut 540.

[0139] The connector tube 544 is received within and sealingly and movably engages the interior surface of the sealing cartridge 518 mounted within the annular recess 516a of the barrel connector 516. In this manner, during longitudinal displacement of the connector tube 544 relative to the barrel connector 516, a fluidic seal is maintained between the exterior surface of the connector tube and the interior surface of the barrel connector.

[0140] The other end of the connector tube 544 is received within and is threadably coupled to a threaded bushing 550. The threaded bushing 550 is received within and threadably coupled to a lock nut 552 that defines radial passages, 552a and 552b, and includes one or more circumferentially spaced apart locking teeth 552c at one end for engaging the circumferentially spaced apart locking teeth 516f of the lower stop 516. The other end of the lock nut 552 receives and is threadably coupled to an end of tool joint adaptor 554 that defines a longitudinal passage 554a, external radial mounting holes, 554b and 554c. Torsional locking pins, 556a and 556b, are mounted within and coupled to the external radial mounting holes, 554b and 554c, respectively, of the tool joint adaptor 554 that are received within the radial passages, 552a and 552b, of the stop nut 552. A sealing sleeve 558 is received within and is threadably coupled to adjacent ends of the connector tube 544 and the tool joint adaptor 554 for fluidically sealing the interface between the end of the connector tube and the end of the tool joint adaptor.

[0141] The other end of the tool joint adaptor 554 is received within and threadably coupled to an end of a tool joint adaptor 560 that defines a longitudinal passage 560a. A torsion plate 562 is received within and threadably coupled to the other end of the tool joint adaptor 560 that defines a longitudinal passage 562a and includes one or more circumferentially spaced apart locking teeth 562b at one end. An end of an upper bushing 564 is also received within and threadably coupled to the other end of the tool joint adaptor 560 proximate the torsion plate 562 that receives and is threadably coupled to an end of a cup mandrel 566 that defines a longitudinal passage 566a and includes a plurality of circumferentially spaced apart locking teeth 566b at one end for engaging the circumferentially spaced apart locking teeth 562b of the torsion plate 562. The end of the cup mandrel 566 is further positioned proximate an end face of the torsion plate 562.

[0142] A thimble 568 is mounted on and is threadably coupled to the cup mandrel 566 proximate an end face of the upper bushing 564. An inner thimble 570 is mounted on and is threadably coupled to the cup mandrel 566 proximate an end of the thimble 568, and one end of the inner thimble is received within and mates with the end of the thimble. A resilient packer cup 572 is mounted on and sealingly engages the cup mandrel 566 proximate an end of the inner thimble 570, and one end of the packer cup is received within and mates with the end of the inner thimble. A packer cup backup ring 574 is mounted on the inner thimble 570 proximate an end face of the thimble 568, and an end of the packer cup backup ring 574 receives and mates with the packer cup 572. A spacer 576 is mounted on and threadably engages the cup mandrel 566 proximate an end face of the packer cup 572.

[0143] A thimble 578 is mounted on and is threadably coupled to the cup mandrel 566 proximate an end of the spacer 576. An inner thimble 580 is mounted on and is threadably coupled to the cup mandrel 566 proximate an end of the thimble 578, and one end of the inner thimble is received within and mates with the end of the thimble. A resilient packer cup 582 is mounted on and sealingly engages the cup mandrel 566 proximate an end of the inner thimble 580, and one end of the packer cup is received within and mates with the end of the inner thimble. A packer cup backup ring 584 is mounted on the inner thimble 580 proximate an end face of the thimble 578, and an end of the packer cup backup ring 584 receives and mates with the packer cup 582. An adjustable spacer 586 is mounted on and threadably engages the cup mandrel 566 proximate an end face of the packer cup 582.

[0144] An end of a cone mandrel 588 that defines a longitudinal passage 588a, an external lock ring groove 588b, an external lock ring groove 588c, an external lock ring groove 588d, an external lock ring groove 588e, radial passages, 588f and 588g, and locking dog grooves 588h receives and is threadably coupled to an end of the cup mandrel 566. A shear pin bushing 590 that defines external radial mounting holes, 590a and 590b, at one end and an annular recess 590c at another end and includes circumferentially spaced apart locking teeth 590d at the other end is mounted on and is movably coupled to the cone mandrel 588. Torsional shear pins, 592a and 592b, are mounted within and coupled to the external radial mounting holes, 590a and 590b, respectively, of the shear pin bushing 590 and received within the radial passages, 470a and 470b, respectively, of the end of the casing 470.

In this manner, torque loads may be transmitted between the casing 470 and the shear pin bushing 590. A resilient lock ring 594 is retained in the external lock ring groove 588b of the cone mandrel and received within the internal annular recess 590c at the end of the shear pin bushing 590.

[0145] Referring to Figs. 24j, 25a, and 25b, an upper cone retainer 596 receives, mates with, and is coupled to the end of the shear pin bushing 590 that includes an internal flange 596a and an internal upper pivot point flange 596b. An end of an upper cam 598 includes a tubular base 598a that mates with, receives, and is movably coupled to the cone mandrel 588. The tubular base 598a of the upper cam 598 further includes an external flange 598b that is received within and mates with the upper cone retainer 596 proximate the internal flange 596a of the upper cone retainer and a plurality of circumferentially spaced apart locking teeth 598c that engage the circumferentially spaced apart locking teeth 590d of the end of the shear pin bushing 590. In this manner, the upper cam 598 is retained within the upper cone retainer 596 and torque loads may be transmitted between the upper cam and the shear pin bushing 590.

[0146] Referring to Figs. 25b and 25c, the upper cam 598 further includes a plurality of circumferentially spaced apart cam arms 598d that extend from the tubular base 598a in the longitudinal direction that mate with, receive, and are movably coupled to the cone mandrel 588. Each cam arm 598d includes an inner surface 598da that is an arcuate cylindrical segment, a first outer surface 598db that is an arcuate cylindrical segment, a second outer surface 598dc that is an arcuate conical segment, and a third outer surface 598dd that is an arcuate cylindrical segment. In an exemplary embodiment, each of the cam arms 598d are identical.

[0147] Referring to Figs. 24j, 25a, and 25d, a plurality of circumferentially spaced apart upper cone segments 600 are interleaved among the cam arms 598d of the upper cam 598. In an exemplary embodiment, each upper cone segment 600 includes a first outer surface 600a that defines a hinge groove 600b, a second outer surface 600c, a third outer surface 600d, a fourth outer surface 600e, a first inner surface 600f, a second inner surface 600g, a third inner surface 600h, and a fourth inner surface 600i. In an exemplary embodiment, the first outer surface 600a, the second outer surface 600c, the fourth outer surface 600e, the first inner surface 600f, the second inner surface 600g, and the fourth inner surface 600i are arcuate cylindrical segments. In an exemplary embodiment, the third outer surface 600d is an arcuate spherical segment. In an exemplary embodiment, the third inner surface 600h is an arcuate conical segment. In an exemplary embodiment, each of the upper cone segments 600 are identical. In an exemplary embodiment, the hinge grooves 600b of the upper cone segments 600 receive and mate with the pivot point 596b of the upper cone retainer 596. In this manner, the upper cone segments 600 are pivotally coupled to the upper cone retainer 596.

[0148] Referring to Figs. 24j, 25a, and 25e, a plurality of circumferentially spaced apart lower cone segments 602 overlap with and are interleaved among the upper cone segments 600. In an exemplary embodiment, each lower cone segment 602 includes a first outer surface 602a that defines a hinge groove 602b, a second outer surface 602c, a third outer surface 602d, a fourth outer surface 602e,

a first inner surface 602f, a second inner surface 602g, a third inner surface 602h, and a fourth inner surface 602i. In an exemplary embodiment, the first outer surface 602a, the second outer surface 602c, the fourth outer surface 602e, the first inner surface 602f, the second inner surface 602g, and the fourth inner surface 602i are arcuate cylindrical segments. In an exemplary embodiment, the third outer surface 602d is an arcuate spherical segment. In an exemplary embodiment, the third inner surface 602h is an arcuate conical segment. In an exemplary embodiment, each of the lower cone segments 602 are identical.

[0149] Referring to Figs. 24j, 25a, 25b, and 25f, a plurality of circumferentially spaced apart cam arms 604a that extend in the longitudinal direction from a tubular base 604b of a lower cam 604 overlap and are interleaved among the circumferentially spaced apart cam arms 598d of the upper cam 598 and mate with, receive, and are movably coupled to the cone mandrel 588. The tubular base 604b of the lower cam 604 mates with, receives, and is movably coupled to the cone mandrel 588 and includes an external flange 604c and a plurality of circumferentially spaced apart locking teeth 604d. Each cam arm 604a includes an inner surface 604aa that is an arcuate cylindrical segment, a first outer surface 604ab that is an arcuate cylindrical segment, a second outer surface 604ac that is an arcuate conical segment, and a third outer surface 604ad that is an arcuate cylindrical segment. In an exemplary embodiment, each of the cam arms 604a are identical.

[0150] An end of a lower cone retainer 606 includes an inner pivot point flange 606a that mates with and is received within the hinge grooves 602b of the lower cone segments 602. In this manner, the lower cone segments 602 are pivotally coupled to the lower cone retainer 606. The lower cone retainer 606 further includes an inner flange 606b that mates with and retains the external flange 604c of the lower cam 604. In this manner, the lower cam 604 is retained within the lower cone retainer 606.

[0151] The other end of the lower cone retainer 606 receives and is threadably coupled to an end of a release housing 608 that defines a radial passage 608a at another end and includes a plurality of circumferentially spaced apart locking teeth 608b at the end of the release housing for engaging the circumferentially spaced apart locking teeth 604d of the lower cam 604. In this manner, torque loads may be transmitted between the release housing 608 and the lower cam 604. An end of a lower mandrel 610 that defines a longitudinal passage 610a, an external radial mounting hole 610b, and radial passages 610c is received within, mates with, and is movably coupled to the other end of the release housing 608. A torsion locking pin 612 is mounted within and coupled to the external radial mounting hole 610b of the lower mandrel 610 and received within the radial passage 608a of the release housing 608. In this manner, longitudinal and torque loads may be transmitted between the release housing 608 and the lower mandrel 610.

[0152] An end of a locking dog retainer sleeve 614 that defines an inner annular recess 614a at one end and includes a plurality of circumferentially spaced apart locking teeth 614b at one end for engaging the locking teeth 604d of the lower cam 604 is received within and threadably coupled to an end of the lower mandrel 610. The locking dog retainer sleeve 614 is also positioned between and

movably coupled to the release housing 608 and the cone mandrel 588. Locking dogs 616 are received within the inner annular recess 614a of the locking dog retainer sleeve 614 that releasably engage the locking dog grooves 588h provided in the exterior surface of the cone mandrel 588. In this manner, the locking dogs 616 releasably limit the longitudinal displacement of the lower cone segments 602, lower cam 604, and the lower cone retainer 606 relative to the cone mandrel 588.

[0153] A locking ring retainer 618 is received within and is threadably coupled to an end of the lower mandrel 610 that defines an inner annular recess 618a for retaining a resilient locking ring 620 within the lock ring groove 588d of the cone mandrel 588. The locking ring retainer 618 further mates with and is movably coupled to the cone mandrel 588. An end of an emergency release sleeve 622 that defines radial passages 622a, an outer annular recess 622b, and a longitudinal passage 622c is received within and is threadably coupled to an end of the lower mandrel 610. The emergency release sleeve 622 is also received within, mates with, and slidably and sealingly engages an end of the cone mandrel 588.

[0154] An end of a pressure balance piston 624 is received within, mates with, and slidably and sealingly engages the end of the lower mandrel 610 and receives, mates with, and is threadably coupled to an end of the cone mandrel 588. The other end of the pressure balance piston 624 receives, mates with, and slidably and sealingly engages the emergency release sleeve 622.

[0155] An end of a bypass valve operating probe 626 that defines a longitudinal passage 626a is received within and is threadably coupled to another end of the lower mandrel 610. An end of an expansion cone mandrel 628 that defines radial passages 628a receives and is threadably coupled to the other end of the lower mandrel 610. A sealing sleeve expansion cone 630 is slidably coupled to the other end of the expansion cone mandrel 628 that includes an outer tapered expansion surface 630a. A guide 632 is releasably coupled to another end of the expansion cone mandrel 628 by a retaining collet 634.

[0156] An end of an expandable sealing sleeve 636 receives and is mounted on the sealing sleeve expansion cone 630 and the guide 632. The other end of the expandable sealing sleeve 636 receives and is threadably coupled to an end of a bypass valve body 638 that defines radial passages, 638a and 638b. An elastomeric coating 640 is coupled to the exterior of at least a portion of the expandable sealing sleeve 636. An end of a probe guide 642 that defines an inner annular recess 642a is received within and is threadably coupled to an end of the bypass valve body 638 and receives and mates with an end of the bypass valve operating probe 626.

[0157] A bypass valve 644 that defines a longitudinal passage 644a and radial passages, 644b and 644c, and includes a collet locking member 644d at one end for releasably engaging an end of the bypass valve operating probe 626 is received within, mates with, and slidably and sealingly engages the bypass valve body 638. An end of a lower mandrel 646 that defines a longitudinal passage 646a receives and is threadably coupled to an end of the bypass valve body 638.

[0158] An end of a dart guide sleeve 648 that defines a longitudinal passage 648a is received within and is coupled to an end of the bypass valve body 638 and the other end of the dart guide sleeve 648 is received within and is coupled with the lower mandrel 646. An end of a differential piston 650 that includes an inner flange 650a at another end receives and is coupled to an end of the lower mandrel 646 by one or more shear pins 652. An end of a float valve assembly 654 including a float valve 654a, a valve guard 654b, and a guide nose 654c receives and is threadably coupled to an end of the lower mandrel 646. A plurality of circumferentially spaced apart locking dogs 656 are pivotally coupled to the inner flange 650a of the differential piston 650 and are further supported by an end of the float valve assembly 654.

[0159] As illustrated in Figs. 24a-24k, in an exemplary embodiment, during operation of the apparatus 400, the apparatus is initially positioned within a preexisting structure 700 such as, for example, a wellbore that traverses a subterranean formation. In several alternative embodiments, the wellbore 700 may have any inclination from vertical to horizontal. Furthermore, in several alternative embodiments, the wellbore 700 may also include one or more preexisting wellbore casings, or other well construction elements, coupled to the wellbore. During the positioning of the apparatus 400 within the wellbore 700, the casings, 468 and 470, are supported by the positive casing locking dog 464 and the torsional shear pins, 592a and 592b. In this manner, axial and torque loads may be transmitted between the casings, 468 and 470, and the tubular support member 402.

[0160] In an exemplary embodiment, as illustrated in Fig. 25h, prior to the assembly of the apparatus 400, the force of the spring 418 applies a sufficient downward longitudinal force to position the ends of the casing gripper locking dogs, 424a and 424b, between the outer annular recesses, 406d and 406e, of the gripper upper mandrel 406 thereby placing the bypass valve body 412 in a neutral position. In an exemplary embodiment, when the apparatus 400 is assembled by inserting the apparatus into the casing 468, the ends of the casing gripper locking dogs, 424a and 424b, impact the upper end of the casing 468 and are thereby displaced, along with the bypass valve body 412, upwardly relative to the gripper upper mandrel 406 until the ends of the casing gripper locking dogs pivot radially inwardly into engagement with the outer annular recess 406d of the gripper upper mandrel. In this manner, the bypass valve body 412 is positioned in an inactive position, as illustrated in Fig. 24a, that fluidically decouples the casing gripper hydraulic ports, 406f and 406h. The upward displacement of the bypass valve body 412 relative to the gripper upper mandrel 406 further compresses the spring 418. The bypass valve body 412 is then maintained in the inactive position due to the placement of the casing gripper locking dogs, 424a and 424b, within the casing 468 thereby preventing the ends of the casing gripper locking dogs from pivoting radially outward out of engagement with the outer annular recess 406d.

[0161] Referring to Figs. 26a-26k, when the apparatus 400 is positioned at a desired predetermined position within the wellbore 700, a fluidic material 702 is injected into the apparatus through the passages 402a, 404a, 406a, 454a, 450a, 456a, 458a, 476a, 478a, 484a, 522a, 529a, 534a, 544a, 554a,

566a, 588a, 622c, 610a, 626a, 644a, and 646a and out of the apparatus through the float valve 654a. In this manner the proper operation of the passages 402a, 404a, 406a, 454a, 450a, 456a, 458a, 476a, 478a, 484a, 522a, 529a, 534a, 544a, 554a, 566a, 588a, 622c, 610a, 626a, 644a, and 646a and the float valve 654a may be tested. A dart 704 is then injected into the apparatus with the fluidic material 702 through the passages 402a, 404a, 406a, 454a, 450a, 456a, 458a, 476a, 478a, 484a, 522a, 529a, 534a, 544a, 554a, 566a, 588a, 622c, 610a, 626a, and 644a until the dart is positioned and seated in the passage 646a of the lower mandrel 646. As a result of the positioning of the dart 704 in the passage 646a of the lower mandrel 646, the passage of the lower mandrel is thereby closed.

[0162] The fluidic material 702 is then injected into the apparatus thereby increasing the operating pressure within the passages 402a, 404a, 406a, 454a, 450a, 456a, 458a, 476a, 478a, 484a, 522a, 529a, 534a, 544a, 554a, 566a, 588a, 622c, 610a, 626a, and 644a. Furthermore, the continued injection of the fluidic material 702 into the apparatus 400 also causes the fluidic material 702 to pass through the radial passages, 526b and 526c, 530b and 530c, and 536b and 536c, of the piston 526, 530, and 536, respectively, into an annular pressure chamber 706 defined between the actuator barrel 492 and the connector tube 529, an annular pressure chamber 708 defined between the actuator barrel 502 and the connector tube 534, and an annular pressure chamber 710 defined between the actuator barrel 512 and the connector tube 544.

[0163] The pressurization of the annular pressure chambers, 706, 708, and 710 then cause the pistons 526, 530, and 536 to be displaced upwardly relative to the casing 470. As a result, the connector tube 529, the connector tube 534, the connector tube 544, the threaded bushing 550, the lock nut 552, the tool joint adaptor 554, the sealing sleeve 558, the tool joint adaptor 560, the torsion plate 562, the upper bushing 564, the cup mandrel 566, the thimble 568, the inner thimble 570, the packer cup 572, the backup ring 574, the spacer 576, the thimble 578, the inner thimble 580, the packer cup 582, the backup ring 584, the spacer 586, and the cone mandrel 588 are displaced upwardly relative to the casing 470, the shear pin bushing 590, the locking ring 594, the upper cone retainer 596, the upper cam 598, and the upper cone segments 600.

[0164] As a result, as illustrated in Figs. 26j, 27a, and 27b, the shear pin bushing 590, the locking ring 594, the upper cone retainer 596, the upper cam 598, and the upper cone segments 600 are displaced downwardly relative to the cone mandrel 588, the lower cone segments 602, and the lower cam 604 thereby driving the upper cone segments 600 onto and up the cam arms 604a of the lower cam 604, and driving the lower cone segments 602 onto and up the cam arms 598d of the upper cam 598. During the outward radial displacement of the upper and lower cone segments, 600 and 602, the upper and cone segments translate towards one another in the longitudinal direction and also pivot about the pivot points, 596b and 606a, of the upper and lower cone retainers, 596 and 606, respectively.

[0165] As a result, a segmented expansion cone is formed that includes a substantially continuous outer arcuate spherical surface provided by the axially aligned and interleaved upper and lower expansion cone segments, 600 and 602. Furthermore, the resilient locking ring 594 is relocated from

the lock ring groove 588b to the lock ring groove 588c thereby releasably locking the positions of the shear pin bushing 590, the locking ring 594, the upper cone retain r 596, the upper cam 598, and the upper cone segments 600 relative to the cone mandrel 588.

[0166] Referring to Figs. 28a to 28j, the continued injection of the fluidic material 702 into the apparatus 400 continues to pressurize annular pressure chambers, 706, 708, and 710. As a result, an upward axial force is applied to the shear pin bushing 590 that causes the torsional shear pins, 592a and 592b, to be sheared thereby decoupling the wellbore casing 470 from the shear pin bushing 590 and permitting the pistons 526, 530, and 536 to be further displaced upwardly relative to the casing 470. The further upward displacement of the pistons 526, 530, and 536 in turn displaces the cone mandrel 588, the upper cam 598, the upper cone segments 600, the lower cone segments 602, and the lower cam 604 upwardly relative to the casing 470. As a result, the segmented expansion cone provided by the interleaved and axially aligned upper and lower cone segments, 600 and 602, radially expands and plastically deforms a portion of the casing 470.

[0167] Referring to Figs. 29a-29m, during the continued injection of the fluidic material 702, the segmented expansion cone provided by the interleaved and axially aligned upper and lower cone segments, 600 and 602, will continue to be displaced upwardly relative to the casing 470 thereby continuing to radially expand and plastically deform the casing until the locking dogs 656 engage and push on the lower end of the casing 470. When the locking dogs 656 engage and push on the lower end of the casing 470, the locking dogs 656, the float valve assembly 654, the differential piston 650, the dart guide sleeve 648, the lower mandrel 646, the bypass valve 644, the elastomeric coating 640, the bypass valve body 638, the expandable sealing sleeve 636, the retaining collet 634, the guide 632, the sealing sleeve expansion cone 630, the expansion cone mandrel 628, the bypass valve operating probe 626, the pressure balance piston 624, the emergency release sleeve 622, the resilient locking ring 620, the locking ring retainer 618, the locking dogs 616, the locking dog retainer sleeve 614, the torsion locking pin 612, the lower mandrel 610, the release housing 608, the lower cone retainer 606, the lower cam 604, and the lower cone segments 602 are displaced downwardly in the longitudinal direction relative to the cone mandrel 588. As a result, the upper cam 598 and the upper cone segments 600 are moved out of axial alignment with the lower cone segments 602 and the lower cam 604 thereby collapsing the segmented expansion cone. Furthermore, the locking ring 620 is moved from the lock ring groove 588d to the lock ring groove 588e thereby releasably fixing the new position of the lower cone segments 602 and the lower cam 604.

[0168] In particular, as illustrated in Fig. 30a, when a downward tensile longitudinal force is initially applied to the lower mandrel 610 relative to cone mandrel 588, the lower mandrel, the locking dog retainer sleeve 614, and the locking ring retainer 618 are displaced downwardly relative to the cone mandrel 588 when the applied tensile force is sufficient to release the locking ring 620 from engagement with the lock ring groove 588d. As illustrated in Fig. 30b, if the applied tensile force is sufficient to release the locking ring 620 from engagement with the lock ring groove 588d, the lower



mandrel 610, the locking dog retainer sleeve 614, and the locking ring retainer 618 are displaced downwardly relative to the cone mandrel 588 thereby displacing the annular recess 614a of the locking dog retainer sleeve downwardly relative to the locking dogs 616. As a result, the locking dogs 616 are released from engagement with the locking dog grooves 588h of the cone mandrel 588 thereby permitting the lower cone segments 602, the lower cam 604, and the lower cone retainer 606 to be displaced downwardly relative to the cone mandrel 588.

[0169] As illustrated in Fig. 30c, further downward displacement of the lower mandrel 610 then causes the torsion locking pin 612 to engage and displace the release housing 608 downwardly relative to the cone mandrel 588 thereby displacing the locking dogs 616, the lower cone retainer 606, the lower cam 604, and the lower cam segments 602 downwardly relative to the cone mandrel. As a result, the lower cone segments 602 and the lower cam 604 are displaced downwardly out of axial alignment with the upper cam 598 and the upper cam segments 600 thereby collapsing the segmented expansion cone. Furthermore, the downward displacement of the locking dog retainer sleeve 614 also displaced the locking ring retainer 618 and the locking ring 620 downwardly relative to the cone mandrel 588 thereby relocating the locking ring from the lock ring groove 588d to the lock ring groove 588e. In this manner, the now position of the lower cone segments 602 and the lower cam 604 are thereby releasably fixed relative to the cam mandrel 588 by the locking ring 620.

[0170] The operations of Figs. 30a-30c may be reversed, and the segmented expansion cone may again be expanded, by applying an upward compressive force to the lower mandrel 610. If the compressive force is sufficient, the locking ring 620 will be released from engagement with the lock ring groove 588e, thereby permitting the lower mandrel 610 and the locking dog retainer 614 to be displaced upwardly relative to the cone mandrel 588. As a result, the locking dog retainer 614 will engage and displace the locking dogs 616, the lower cam 604, the lower cone segments 602, the lower cone retainer 606, and the release housing 608 upwardly relative to the cone mandrel 588 thereby bringing the upper cam 598 and the upper cone segments 600 back into axial alignment with the lower cone segments 602 and the lower cam 604. As a result, the segmented expansion cone is once again expanded. Once the segmented cone has been fully expanded, the locking dogs 616 will once again be positioned in alignment with the locking dog grooves 588h of the cone mandrel 588 and will thereby once again engage the locking dog grooves. The continued upward displacement of the lower mandrel 610 relative to cone mandrel 588 will thereby also upwardly displace the locking dog retainer 614 upwardly relative to the cone mandrel thereby once again capturing and restraining the locking dogs 616 within the annular recess 614a of the locking dog retainer. As a result, the new expansion position of the lower cone segments 602 and the lower cam 604 relative to the cone mandrel 588 will be releasably locked by the locking dogs 616. Furthermore, the locking ring 620 will also be relocated from engagement with the lock ring groove 588e to engagement with the lock ring groove 588d thereby releasably lock the expanded segmented cone in the expanded position.

[0171] Referring to Figs. 31a-31n, the continued injection of the fluidic material 702 into the apparatus 400 continues to pressurize the piston chambers 706, 708, and 710 thereby further displacing the pistons upwardly 526, 530, and 536 upwardly relative to the support member 402. Because the engagement of the locking dogs 656 with the lower end of the casing 470 prevents float valve 654 from entering the casing, the continued upward displacement of the pistons 526, 530, and 536 relative to the support member 402 causes the bypass valve operating probe 626 to be displaced upwardly relative to the support member thereby disengaging the bypass valve operating probe from the probe guide 642, and also causes the sealing sleeve expansion cone 630 to be displaced upwardly relative to the expandable sealing sleeve 636 thereby radially expanding and plastically deforming the sealing sleeve 636 and the elastomeric coating 640 into sealing engagement with the interior surface of the lower end of the casing 470. As a result, the lower end of the casing 470 is fluidically sealed by the combination of the sealing engagement of the sealing sleeve 636 and elastomeric coating 640 with the interior surface of the lower end of the casing and the positioning the dart 704 within the passage 646a of the lower mandrel 646.

[0172] Continued injection of the fluidic material 702 into the apparatus 400 continues to pressurize the piston chambers 706, 708, and 710 until the pistons 536, 530 and 536 are displaced upwardly relative to the casing 470 to their maximum upward position relative to the support member 402. As a result, the dart ball guide 524 impacts the positive casing lock mandrel 478 with sufficient force to shear the shear pins, 428a and 428b, thereby decoupling the positive casing lock mandrel 478 from the casing lock barrel adaptor 474. The positive casing lock mandrel 478 is then displaced upwardly relative to the support member 402 which in turn displaces the positive casing lock releasing mandrel 476 upwardly relative to the positive casing locking dogs 464. As a result, the internal flanges, 464a and 464b, of the positive casing locking dogs are relocated into engagement with the annular recesses, 476c and 476d, respectively, of the positive casing lock releasing mandrel 476. The positive casing lock casing collar 466 is thereby released from engagement with the positive casing locking dogs 464 thereby releasing the casings 468 and 470 from engagement with the support member 402. As a result, the positions of the casings, 468 and 470, are no longer fixed relative to the support member 402.

[0173] Referring to Figs. 32a-32k, the injection of the fluidic material 702 is stopped and the support member 402 is then lowered into the wellbore 700 until the float valve assembly 654 impacts the bottom of the wellbore. The support member 402 is then further lowered into the wellbore 700, with the float valve assembly 654 resting on the bottom of the wellbore, until the bypass valve operating probe 626 impacts and displaces the bypass valve 644 downwardly relative to the bypass valve body 638 to fluidically couple the passages, 638a and 644b, and the passages, 638b and 644c, and until sufficient upward compressive force has been applied to the lower mandrel 610 to re-expand the segmented expansion cone provided by the cone segments, 600 and 602. In an exemplary embodiment, the collet locking member 644d of the bypass valve 644 will also engage an end of the bypass valve operating probe 626.

[0174] In an exemplary embodiment, the support member 402 is lowered downwardly into the wellbore 700 such that sufficient upward compressive force is applied to the lower mandrel 610 to release the locking ring 620 from engagement with the lock ring groove 588e, thereby permitting the lower mandrel 610 and the locking dog retainer 614 to be displaced upwardly relative to the cone mandrel 588. As a result, the locking dog retainer 614 will engage and displace the locking dogs 616, the lower cam 604, the lower cone segments 602, the lower cone retainer 606, and the release housing 608 upwardly relative to the cone mandrel 588 thereby bringing the upper cam 598 and the upper cone segments 600 back into axial alignment with the lower cone segments 602 and the lower cam 604. As a result, the segmented expansion cone is once again expanded. Once the segmented cone has been fully expanded, the locking dogs 616 will once again be positioned in alignment with the locking dog grooves 588h of the cone mandrel 588 and will thereby once again engage the locking dog grooves. The continued upward displacement of the lower mandrel 610 relative to cone mandrel 588 will thereby also upwardly displace the locking dog retainer 614 upwardly relative to the cone mandrel thereby once again capturing and restraining the locking dogs 616 within the annular recess 614a of the locking dog retainer. As a result, the new expansion position of the lower cone segments 602 and the lower cam 604 relative to the cone mandrel 588 will be releasably locked by the locking dogs 616. Furthermore, the locking ring 620 will also be relocated from engagement with the lock ring groove 588e to engagement with the lock ring groove 588d to thereby releasably lock the expanded segmented cone in the expanded position.

[0175] A hardenable fluidic sealing material 712 may then be injected into the apparatus 400 through the passages 402a, 404a, 406a, 454a, 450a, 456a, 458a, 476a, 478a, 522a, 526a, 529a, 530a, 534a, 536a, 544a, 554a, 566a, 588a, 622a, 610a, 626a, 638a, 638b, 644b, and 644c, and out of the apparatus through the circumferential gaps defined between the circumferentially spaced apart locking dogs 656 into the annulus between the casings 468 and 470 and the wellbore 700. In an exemplary embodiment, the hardenable fluidic sealing material 712 is a cement suitable for well construction. The hardenable fluidic sealing material 712 may then be allowed to cure before or after the further radial expansion and plastic deformation of the casings 468 and/or 470.

[0176] Referring to Figs. 33a-33p, after completing the injection of the fluidic material 712, the support member 402 is then lifted upwardly thereby displacing the bypass valve operating probe 626 and the bypass valve 644 upwardly to fluidically decouple the passages, 638a and 644b and 638b and 644c, until the collet locking member 644d of the bypass valve is decoupled from the bypass valve operating probe. The support member 402 is then further lifted upwardly until the segmented expansion cone, provided by the interleaved and axially aligned cone segments, 600 and 602, impacts the transition between the expanded and unexpanded sections of the casing 470. A fluidic material 714 is then injected into the apparatus 400 through the passages 402a, 404a, 406a, 454a, 450a, 456a, 458a, 476a, 478a, 484a, 524a, 522a, 526a, 529a, 530a, 534a, 536a, 544a, 554a, 566a, 588a, 622c, 610a, and 626a thereby pressurizing the interior portion of the casing 470 below the packer cups, 572 and 582. In

particular, the packer cups, 572 and 582, engage the interior surface of the casings 468 and/or 470 and thereby provide a dynamic movable fluidic seal. As a result, the pressure differential across the packer cups, 572 and 582, causes an upward tensile force that pulls the segmented expansion cone provided by the axially aligned and interleaved cone segments, 600 and 602, to be pulled upwardly out of the casings 468 and/or 470 by the packer cups thereby radially expanding and plastically deforming the casings. Furthermore, the lack of a fluid tight seal between the cone segments, 572 and 582, and the casings 468 and/or 470 permits the fluidic material 714 to lubricate the interface between the cone segments and the casings during the radial expansion and plastic deformations of the casings by the cone segments. In an exemplary embodiment, during the radial expansion and plastic deformation of the wellbore casings 468 and/or 470, the support member 402 is lifted upwardly out of the wellbore 700. In several alternative embodiments, the casings 468 and/or 470 are radially expanded and plastically deformed into engagement with at least a portion of the interior surface of the wellbore 700.

[0177] Referring to Figs. 34a-34l, in an exemplary embodiment, a preexisting wellbore casing 716 is coupled to, or otherwise supported by or within, the wellbore 700. In an exemplary embodiment, during the radial expansion and plastic deformation of the portion of the casing 468 and/or 470 that overlaps with the preexisting casing 716, during the continued injection of the fluidic material 714, the bypass valve body 412 is shifted downwardly relative to the gripper upper mandrel 406 thereby fluidically coupling the casing gripper hydraulic ports, 406f and 406h. As a result, the interior passages, 428a and 440a, of the gripper bodies, 428 and 440, are pressurized thereby displacing the hydraulic slip pistons, 432a-432j and 442a-442j, radially outward into engagement with the interior surface of the preexisting wellbore casing 716. After the hydraulic slip pistons, 432a-432j and 442a-442j, engage the preexisting wellbore casing 716, the continued injection of the fluidic material 714 causes the segmented expansion cone including the axially aligned and interleaved cone segments, 600 and 602, to be pulled through the overlapping portions of the casings 468 and/or 470 and the preexisting wellbore casing by the upward displacement of the pistons, 526, 530, and 536, relative to the preexisting wellbore casing. In this manner, the overlapping portions of the casings 468 and/or 470 and the preexisting wellbore casing 716 are simultaneously radially expanded and plastically deformed by the upward displacement of the segmented expansion cone including the axially aligned and interleaved cone segments, 600 and 602. In several alternative embodiments, the hydraulic slip pistons, 432a-432j and 442a-442j, are displaced radially outward into engagement with the interior surface of the casings 468 and/or 470 and/or the preexisting wellbore casing 716.

[0178] In an exemplary embodiment, the bypass valve body 412 is shifted downwardly relative to the gripper upper mandrel 406 by lowering the casing gripper locking dogs, 424a and 424b, using the support member 402 to a position below the unexpanded portions of the casings 468 and/or 470 into the radially expanded and plastically deformed portions of the casings. The ends of the casing gripper locking dogs, 424a and 424b, may then pivot outwardly out of engagement with the outer annular recess 406d of the gripper upper mandrel 406 and then are displaced downwardly relative to the gripper

upper mandrel, along with the bypass valve body 412, due to the downward longitudinal force provided by the compressed spring 418. As a result, the bypass valve body 412 is placed in the neutral position illustrated in Fig. 25h. The casing gripper locking dogs, 424a and 424b, are then displaced upwardly relative to the casing gripper upper mandrel 406 using the support member 402 thereby impacting the casing gripper locking dogs with the interior diameter of the unexpanded portion of the casings 468 and/or 470. As a result, the casing gripper locking dogs, 424a and 424b, are displaced downwardly, along with the bypass valve body 412, relative to the casing gripper upper mandrel 406 until the ends of the casing gripper locking dogs pivot radially inwardly into engagement with the outer annular recess 406e of the casing gripper upper mandrel thereby positioning the bypass valve body in an active position, as illustrated in Fig. 34a, in which the casing gripper hydraulic ports, 406f and 406h, are fluidically coupled.

[0179] In an alternative embodiment, the bypass valve body 412 is shifted downwardly relative to the gripper upper mandrel 406 by raising the casing gripper locking dogs, 424a and 424b, to a position above the casing 468 using the support member 402 thereby permitting the ends of the casing gripper locking dogs to pivot radially outward out of engagement with the outer annular recess 406d of the gripper upper mandrel 406. The ends of the casing gripper locking dogs, 424a and 424b, are then displaced downwardly relative to the gripper upper mandrel, along with the bypass valve body 412, due to the downward longitudinal force provided by the compressed spring 418, into engagement with the outer annular recess 406e of the casing gripper upper mandrel thereby positioning the bypass valve body in an active position, as illustrated in Fig. 34a, in which the casing gripper hydraulic ports, 406f and 406h, are fluidically coupled.

[0180] In an exemplary embodiment, the process of pulling the segmented expansion cone provided by pulling the interleaved and axially aligned cone segments, 600 and 602, upwardly through the overlapping portions of the casings 468 and/or 470 and the preexisting wellbore casing 716 is repeated by repeatedly stroking the pistons, 526, 530, and 536, upwardly by repeatedly a) injecting the fluidic material 714 to pressurize the apparatus 400 thereby displacing the segmented expansion cone upwardly, b) depressurizing the apparatus by halting the injection of the fluidic material, and then c) lifting the elements of the apparatus upwardly using the support member 402 in order to properly position the pistons for another upward stroke.

[0181] Referring to Figs. 35a-35l, in an exemplary embodiment, during the operation of the apparatus 400, the segmented expansion cone provided by the interleaved and axially aligned cone segments, 600 and 602, may be collapsed thereby moving the cone segments out of axial alignment by injecting a ball plug 718 into the apparatus using the injected fluidic material 714 through the passages 402a, 404a, 406a, 454a, 450a, 456a, 458a, 476a, 484a, 522a, 529a, 534a, 544a, 554a, 566a, and 588a into sealing engagement with the end of the emergency releasing sleeve 622. The continued injection of the fluidic material 714 following the sealing engagement of the ball plug 718 with the end of the emergency releasing sleeve 622 will apply a downward longitudinal tensile force to the lower mandrel

610. As a result, as illustrated and described above with reference to Fig. 30a, when the downward tensile longitudinal force is initially applied to the lower mandrel 610 relative to cone mandrel 588, the lower mandrel, the locking dog retainer sleeve 614, and the locking ring retainer 618 are displaced downwardly relative to the cone mandrel 588 when the applied tensile force is sufficient to release the locking ring 620 from engagement with the lock ring groove 588d. As illustrated in Fig. 30b, if the applied downward tensile longitudinal force is sufficient to release the locking ring 620 from engagement with the lock ring groove 588d, the lower mandrel 610, the locking dog retainer sleeve 614, and the locking ring retainer 618 are displaced downwardly relative to the cone mandrel 588 thereby displacing the annular recess 614a of the locking dog retainer sleeve downwardly relative to the locking dogs 616. As a result, the locking dogs 616 are released from engagement with the locking dog grooves 588h of the cone mandrel 588 thereby permitting the lower cone segments 602, the lower cam 604, and the lower cone retainer 606 to be displaced downwardly relative to the cone mandrel 588.

[0182] As illustrated in Fig. 30c, further downward displacement of the lower mandrel 610 then causes the torsion locking pin 612 to engage and displace the release housing 608 downwardly relative to the cone mandrel 588 thereby displacing the locking dogs 616, the lower cone retainer 606, the lower cam 604, and the lower cam segments 602 downwardly relative to the cone mandrel. As a result, the lower cone segments 602 and the lower cam 604 are displaced downwardly out of axial alignment with the upper cam 598 and the upper cam segments 600 thereby collapsing the segmented expansion cone. Furthermore, the downward displacement of the locking dog retainer sleeve 614 also displaced the locking ring retainer 618 and the locking ring 620 downwardly relative to the cone mandrel 588 thereby relocating the locking ring from the lock ring groove 588d to the lock ring groove 588e. In this manner, the now position of the lower cone segments 602 and the lower cam 604 are thereby releasably fixed relative to the cam mandrel 588 by the locking ring 620.

[0183] Referring now to Fig. 36a, an exemplary embodiment of the operation of the pressure balance piston 624 during an exemplary embodiment of the operation of the apparatus 400 will now be described. In particular, after the dart 704 is positioned and seated in the passage 646a of the lower mandrel 646, the operating pressure within the passage 622c will increase. As a result, the operating pressure within the passages 622a will increase thereby increasing the operating pressures within the passages, 588f and 588g, of the cone mandrel 588, and within an annulus 720 defined between the cone mandrel 588 and lower mandrel 610. The operating pressure within the annulus 720 acts upon an end face of the pressure balance piston 624 thereby applying a downward longitudinal force to the cone mandrel 588. As a result, the cone mandrel 588 and the locking dog retainer sleeve 614 could inadvertently be displaced away from each other in opposite directions during the pressurization of the interior passages of the apparatus 400 caused by the placement of the dart 704 in the passage 646a of the lower mandrel 646 thereby potentially collapsing the segmented expansion cone including the interleaved and axially aligned cone segments, 600 and 602. Thus, the pressure balance piston 624, in an exemplary embodiment, neutralizes the potential effects of the pressurization of the interior passages

of the apparatus 400 caused by the placement of the dart 704 in the passage 646a of the lower mandrel 646.

[0184] Referring now to Fig. 36b, an exemplary embodiment of the operation of the pressure balance piston 624 during another exemplary embodiment of the operation of the apparatus 400 will now be described. In particular, during the placement of the ball 718 within the passage 622c of the releasing sleeve 622, the interior passages of the apparatus 400 upstream from the ball are pressurized. However, since the ball 718 blocks the passage 622c, the passage 622a is not pressurized. As a result, the pressure balance piston 624 does not apply a downward longitudinal force to the cone mandrel 588. As a result, the pressure balance piston 624 does not interfere with the collapse of the segmented expansion cone including the interleaved and axially aligned cone segments, 600 and 602, caused by the placement of the ball 718 within the mouth of the passage 622c of the release sleeve 622.

[0185] An apparatus for radially expanding and plastically deforming an expandable tubular member has been described that includes a float shoe adapted to mate with an end of the expandable tubular member, an adjustable expansion mandrel coupled to the float shoe adapted to be controllably expanded to a larger outside dimension for radial expansion of the expandable tubular member or collapsed to a smaller outside dimension, an actuator coupled to the adjustable expansion mandrel adapted to controllably displace the adjustable expansion mandrel relative to the expandable tubular member, a locking device coupled to the actuator adapted to controllably engage the expandable tubular member, and a support member coupled to the locking device.

[0186] A method for radially expanding and plastically deforming an expandable tubular member within a borehole has been described that includes positioning an adjustable expansion mandrel within the expandable tubular member, supporting the expandable tubular member and the adjustable expansion mandrel within the borehole, lowering the adjustable expansion mandrel out of the expandable tubular member, increasing the outside dimension of the adjustable expansion mandrel, and displacing the adjustable expansion mandrel upwardly relative to the expandable tubular member n times to radially expand and plastically deform n portions of the expandable tubular member.

[0187] A method for forming a mono diameter wellbore casing has been described that includes positioning an adjustable expansion mandrel within a first expandable tubular member, supporting the first expandable tubular member and the adjustable expansion mandrel within a borehole, lowering the adjustable expansion mandrel out of the first expandable tubular member, increasing the outside dimension of the adjustable expansion mandrel, displacing the adjustable expansion mandrel upwardly relative to the first expandable tubular member m times to radially expand and plastically deform m portions of the first expandable tubular member within the borehole, positioning the adjustable expansion mandrel within a second expandable tubular member, supporting the second expandable tubular member and the adjustable expansion mandrel within the borehole in overlapping relation to the first expandable tubular member, lowering the adjustable expansion mandrel out of the second expandable tubular member, increasing the outside dimension of the adjustable expansion mandrel, and

displacing the adjustable expansion mandrel upwardly relative to the second expandable tubular member  $n$  times to radially expand and plastically deform  $n$  portions of the second expandable tubular member within the borehole.

[0188] An apparatus for radially expanding and plastically deforming an expandable tubular member has been described that includes a float shoe adapted to mate with an end of the expandable tubular member, an adjustable expansion mandrel coupled to the float shoe adapted to be controllably expanded to a larger outside dimension for radial expansion of the expandable tubular member or collapsed to a smaller outside dimension, an actuator coupled to the adjustable expansion mandrel adapted to controllably displace the adjustable expansion mandrel relative to the expandable tubular member, a locking device coupled to the actuator adapted to controllably engage the expandable tubular member, a support member coupled to the locking device, and a sealing member for sealingly engaging the expandable tubular member adapted to define a pressure chamber above the adjustable expansion mandrel during radial expansion of the expandable tubular member.

[0189] A method for radially expanding and plastically deforming an expandable tubular member within a borehole has been described that includes positioning an adjustable expansion mandrel within the expandable tubular member, supporting the expandable tubular member and the adjustable expansion mandrel within the borehole, lowering the adjustable expansion mandrel out of the expandable tubular member, increasing the outside dimension of the adjustable expansion mandrel, displacing the adjustable expansion mandrel upwardly relative to the expandable tubular member  $n$  times to radially expand and plastically deform  $n$  portions of the expandable tubular member within the borehole, and pressurizing an interior region of the expandable tubular member above the adjustable expansion mandrel during the radial expansion and plastic deformation of the expandable tubular member within the borehole.

[0190] A method for forming a mono diameter wellbore casing has been described that includes positioning an adjustable expansion mandrel within a first expandable tubular member, supporting the first expandable tubular member and the adjustable expansion mandrel within a borehole, lowering the adjustable expansion mandrel out of the first expandable tubular member, increasing the outside dimension of the adjustable expansion mandrel, displacing the adjustable expansion mandrel upwardly relative to the first expandable tubular member  $m$  times to radially expand and plastically deform  $m$  portions of the first expandable tubular member within the borehole, pressurizing an interior region of the first expandable tubular member above the adjustable expansion mandrel during the radial expansion and plastic deformation of the first expandable tubular member within the borehole, positioning the adjustable expansion mandrel within a second expandable tubular member, supporting the second expandable tubular member and the adjustable expansion mandrel within the borehole in overlapping relation to the first expandable tubular member, lowering the adjustable expansion mandrel out of the second expandable tubular member, increasing the outside dimension of the adjustable expansion mandrel, displacing the adjustable expansion mandrel upwardly relative to the second



expandable tubular member  $n$  times to radially expand and plastically deform  $n$  portions of the second expandable tubular member within the borehole, and pressurizing an interior region of the second expandable tubular member above the adjustable expansion mandrel during the radial expansion and plastic deformation of the second expandable tubular member within the borehole.

[0191] An apparatus for drilling a borehole within a subterranean formation and then radially expanding and plastically deforming an expandable tubular member within the drilled borehole has been described that includes a float shoe adapted to mate with an end of the expandable tubular member, a drilling member coupled to the float shoe adapted to drill the borehole, an adjustable expansion mandrel coupled to the float shoe adapted to be controllably expanded to a larger outside dimension for radial expansion of the expandable tubular member or collapsed to a smaller outside dimension, an actuator coupled to the adjustable expansion mandrel adapted to controllably displace the adjustable expansion mandrel relative to the expandable tubular member, a locking device coupled to the actuator adapted to controllably engage the expandable tubular member, and a support member coupled to the locking device.

[0192] A method for drilling a borehole within a subterranean formation and then radially expanding and plastically deforming an expandable tubular member within the drilled borehole has been described that includes positioning an adjustable expansion mandrel within the expandable tubular member, coupling a drilling member to an end of the expandable tubular member, drilling the borehole using the drilling member, positioning the adjustable expansion mandrel and the expandable tubular member within the drilled borehole, lowering the adjustable expansion mandrel out of the expandable tubular member, increasing the outside dimension of the adjustable expansion mandrel, and displacing the adjustable expansion mandrel upwardly relative to the expandable tubular member  $n$  times to radially expand and plastically deform  $n$  portions of the expandable tubular member within the drilled borehole.

[0193] A method for forming a mono diameter wellbore casing within a borehole has been described that includes positioning an adjustable expansion mandrel within a first expandable tubular member, coupling a drilling member to an end of the first expandable tubular member, drilling a first section of the borehole using the drilling member, supporting the first expandable tubular member and the adjustable expansion mandrel within the drilled first section of the borehole, lowering the adjustable expansion mandrel out of the first expandable tubular member, increasing the outside dimension of the adjustable expansion mandrel, displacing the adjustable expansion mandrel upwardly relative to the first expandable tubular member  $m$  times to radially expand and plastically deform  $m$  portions of the first expandable tubular member within the drilled first section of the borehole, positioning the adjustable expansion mandrel within a second expandable tubular member, coupling the drilling member to an end of the second expandable tubular member, drilling a second section of the borehole using the drilling member, supporting the second expandable tubular member and the adjustable expansion mandrel within the borehole in overlapping relation to the first expandable tubular member

within the second drilled section of the borehole, lowering the adjustable expansion mandrel out of the second expandable tubular member, increasing the outside dimension of the adjustable expansion mandrel, and displacing the adjustable expansion mandrel upwardly relative to the second expandable tubular member  $n$  times to radially expand and plastically deform  $n$  portions of the second expandable tubular member within the drilled second section of the borehole.

[0194] An apparatus for drilling a borehole within a subterranean formation and then radially expanding and plastically deforming an expandable tubular member within the drilled borehole has been described that includes a float shoe adapted to mate with an end of the expandable tubular member, a drilling member coupled to the float shoe adapted to drill the borehole, an adjustable expansion mandrel coupled to the float shoe adapted to be controllably expanded to a larger outside dimension for radial expansion of the expandable tubular member or collapsed to a smaller outside dimension, an actuator coupled to the adjustable expansion mandrel adapted to controllably displace the adjustable expansion mandrel relative to the expandable tubular member, a locking device coupled to the actuator adapted to controllably engage the expandable tubular member, a support member coupled to the locking device, and a sealing member for sealing engaging the expandable tubular member adapted to define a pressure chamber above the adjustable expansion mandrel during the radial expansion of the expandable tubular member.

[0195] A method for drilling a borehole within a subterranean formation and then radially expanding and plastically deforming an expandable tubular member within the drilled borehole has been described that includes positioning an adjustable expansion mandrel within the expandable tubular member, coupling a drilling member to an end of the expandable tubular member, drilling the borehole using the drilling member, positioning the adjustable expansion mandrel and the expandable tubular member within the drilled borehole, lowering the adjustable expansion mandrel out of the expandable tubular member, increasing the outside dimension of the adjustable expansion mandrel, displacing the adjustable expansion mandrel upwardly relative to the expandable tubular member  $n$  times to radially expand and plastically deform  $n$  portions of the expandable tubular member within the drilled borehole, and pressuring an interior portion of the expandable tubular member above the adjustable expansion mandrel during the radial expansion and plastic deformation of the expandable tubular member within the drilled borehole.

[0196] A method for forming a mono diameter wellbore casing within a borehole has been described that includes positioning an adjustable expansion mandrel within a first expandable tubular member, coupling a drilling member to an end of the first expandable tubular member, drilling a first section of the borehole using the drilling member, supporting the first expandable tubular member and the adjustable expansion mandrel within the drilled first section of the borehole, lowering the adjustable expansion mandrel out of the first expandable tubular member, increasing the outside dimension of the adjustable expansion mandrel, displacing the adjustable expansion mandrel upwardly relative to the first expandable tubular member  $m$  times to radially expand and plastically deform  $m$  portions of the

first expandable tubular member within the drilled first section of the borehole, pressuring an interior portion of the first expandable tubular member above the adjustable expansion mandrel during the radial expansion and plastic deformation of the first expandable tubular member within the first drilled section of the borehole, positioning the adjustable expansion mandrel within a second expandable tubular member, coupling the drilling member to an end of the second expandable tubular member, drilling a second section of the borehole using the drilling member, supporting the second expandable tubular member and the adjustable expansion mandrel within the borehole in overlapping relation to the first expandable tubular member within the second drilled section of the borehole, lowering the adjustable expansion mandrel out of the second expandable tubular member, increasing the outside dimension of the adjustable expansion mandrel, displacing the adjustable expansion mandrel upwardly relative to the second expandable tubular member  $n$  times to radially expand and plastically deform  $n$  portions of the second expandable tubular member within the drilled second section of the borehole, and pressuring an interior portion of the second expandable tubular member above the adjustable expansion mandrel during the radial expansion and plastic deformation of the second expandable tubular member within the drilled second section of the borehole.

[0197] An apparatus for radially expanding and plastically deforming an expandable tubular member has been described that includes a float shoe adapted to mate with an end of the expandable tubular member, a first adjustable expansion mandrel coupled to the float shoe adapted to be controllably expanded to a first larger outside dimension for radial expansion of the expandable tubular member or collapsed to a first smaller outside dimension, a second adjustable expansion mandrel coupled to the first adjustable expansion mandrel adapted to be controllably expanded to a second larger outside dimension for radial expansion of the expandable tubular member or collapsed to a second smaller outside dimension, an actuator coupled to the first and second adjustable expansion mandrels adapted to controllably displace the first and second adjustable expansion mandrels relative to the expandable tubular member, a locking device coupled to the actuator adapted to controllably engage the expandable tubular member, and a support member coupled to the locking device. The first larger outside dimension of the first adjustable expansion mandrel is larger than the second larger outside dimension of the second adjustable expansion mandrel.

[0198] A method for radially expanding and plastically deforming an expandable tubular member within a borehole has been described that includes positioning first and second adjustable expansion mandrels within the expandable tubular member, supporting the expandable tubular member and the first and second adjustable expansion mandrels within the borehole, lowering the first adjustable expansion mandrel out of the expandable tubular member, increasing the outside dimension of the first adjustable expansion mandrel, displacing the first adjustable expansion mandrel upwardly relative to the expandable tubular member to radially expand and plastically deform a lower portion of the expandable tubular member, displacing the first adjustable expansion mandrel and the second adjustable expansion mandrel downwardly relative to the expandable tubular member, decreasing the

outside dimension of the first adjustable expansion mandrel and increasing the outside dimension of the second adjustable expansion mandrel, and displacing the second adjustable expansion mandrel upwardly relative to the expandable tubular member to radially expand and plastically deform portions of the expandable tubular member above the lower portion of the expandable tubular member. The outside dimension of the first adjustable expansion mandrel is greater than the outside dimension of the second adjustable expansion mandrel.

[0199] A method for forming a mono diameter wellbore casing has been described that includes positioning first and second adjustable expansion mandrels within a first expandable tubular member, supporting the first expandable tubular member and the first and second adjustable expansion mandrels within a borehole, lowering the first adjustable expansion mandrel out of the first expandable tubular member, increasing the outside dimension of the first adjustable expansion mandrel, displacing the first adjustable expansion mandrel upwardly relative to the first expandable tubular member to radially expand and plastically deform a lower portion of the first expandable tubular member, displacing the first adjustable expansion mandrel and the second adjustable expansion mandrel downwardly relative to the first expandable tubular member, decreasing the outside dimension of the first adjustable expansion mandrel and increasing the outside dimension of the second adjustable expansion mandrel, displacing the second adjustable expansion mandrel upwardly relative to the first expandable tubular member to radially expand and plastically deform portions of the first expandable tubular member above the lower portion of the expandable tubular member, positioning first and second adjustable expansion mandrels within a second expandable tubular member, supporting the first expandable tubular member and the first and second adjustable expansion mandrels within the borehole in overlapping relation to the first expandable tubular member, lowering the first adjustable expansion mandrel out of the second expandable tubular member, increasing the outside dimension of the first adjustable expansion mandrel, displacing the first adjustable expansion mandrel upwardly relative to the second expandable tubular member to radially expand and plastically deform a lower portion of the second expandable tubular member, displacing the first adjustable expansion mandrel and the second adjustable expansion mandrel downwardly relative to the second expandable tubular member, decreasing the outside dimension of the first adjustable expansion mandrel and increasing the outside dimension of the second adjustable expansion mandrel, and displacing the second adjustable expansion mandrel upwardly relative to the second expandable tubular member to radially expand and plastically deform portions of the second expandable tubular member above the lower portion of the second expandable tubular member. The outside dimension of the first adjustable expansion mandrel is greater than the outside dimension of the second adjustable expansion mandrel.

[0200] An apparatus for radially expanding and plastically deforming an expandable tubular member has been described that includes a float shoe adapted to mate with an end of the expandable tubular member, a first adjustable expansion mandrel coupled to the float shoe adapted to be controllably expanded to a first larger outside dimension for radial expansion of the expandable tubular

member or collapsed to a first smaller outside dimension, a second adjustable expansion mandrel coupled to the first adjustable expansion mandrel adapted to be controllably expanded to a second larger outside dimension for radial expansion of the expandable tubular member or collapsed to a second smaller outside dimension, an actuator coupled to the first and second adjustable expansion mandrels adapted to controllably displace the first and second adjustable expansion mandrels relative to the expandable tubular member, a locking device coupled to the actuator adapted to controllably engage the expandable tubular member, a support member coupled to the locking device, and a sealing member for sealingly engaging the expandable tubular adapted to define a pressure chamber above the first and second adjustable expansion mandrels during the radial expansion of the expandable tubular member. The first larger outside dimension of the first adjustable expansion mandrel is larger than the second larger outside dimension of the second adjustable expansion mandrel.

[0201] A method for radially expanding and plastically deforming an expandable tubular member within a borehole has been described that includes positioning first and second adjustable expansion mandrels within the expandable tubular member, supporting the expandable tubular member and the first and second adjustable expansion mandrels within the borehole, lowering the first adjustable expansion mandrel out of the expandable tubular member, increasing the outside dimension of the first adjustable expansion mandrel, displacing the first adjustable expansion mandrel upwardly relative to the expandable tubular member to radially expand and plastically deform a lower portion of the expandable tubular member, pressurizing an interior region of the expandable tubular member above the first adjustable expansion mandrel during the radial expansion of the lower portion of the expandable tubular member by the first adjustable expansion mandrel, displacing the first adjustable expansion mandrel and the second adjustable expansion mandrel downwardly relative to the expandable tubular member, decreasing the outside dimension of the first adjustable expansion mandrel and increasing the outside dimension of the second adjustable expansion mandrel, displacing the second adjustable expansion mandrel upwardly relative to the expandable tubular member to radially expand and plastically deform portions of the expandable tubular member above the lower portion of the expandable tubular member, and pressurizing an interior region of the expandable tubular member above the second adjustable expansion mandrel during the radial expansion of the portions of the expandable tubular member above the lower portion of the expandable tubular member by the second adjustable expansion mandrel. The outside dimension of the first adjustable expansion mandrel is greater than the outside dimension of the second adjustable expansion mandrel.

[0202] A method for forming a mono diameter wellbore casing has been described that includes positioning first and second adjustable expansion mandrels within a first expandable tubular member, supporting the first expandable tubular member and the first and second adjustable expansion mandrels within a borehole, lowering the first adjustable expansion mandrel out of the first expandable tubular member, increasing the outside dimension of the first adjustable expansion mandrel, displacing the first adjustable expansion mandrel upwardly relative to the first expandable tubular member to radially

expand and plastically deform a lower portion of the first expandable tubular member, pressurizing an interior region of the first expandable tubular member above the first adjustable expansion mandrel during the radial expansion of the lower portion of the first expandable tubular member by the first adjustable expansion mandrel, displacing the first adjustable expansion mandrel and the second adjustable expansion mandrel downwardly relative to the first expandable tubular member, decreasing the outside dimension of the first adjustable expansion mandrel and increasing the outside dimension of the second adjustable expansion mandrel, displacing the second adjustable expansion mandrel upwardly relative to the first expandable tubular member to radially expand and plastically deform portions of the first expandable tubular member above the lower portion of the expandable tubular member, pressurizing an interior region of the first expandable tubular member above the second adjustable expansion mandrel during the radial expansion of the portions of the first expandable tubular member above the lower portion of the first expandable tubular member by the second adjustable expansion mandrel, positioning first and second adjustable expansion mandrels within a second expandable tubular member, supporting the first expandable tubular member and the first and second adjustable expansion mandrels within the borehole in overlapping relation to the first expandable tubular member, lowering the first adjustable expansion mandrel out of the second expandable tubular member, increasing the outside dimension of the first adjustable expansion mandrel, displacing the first adjustable expansion mandrel upwardly relative to the second expandable tubular member to radially expand and plastically deform a lower portion of the second expandable tubular member, pressurizing an interior region of the second expandable tubular member above the first adjustable expansion mandrel during the radial expansion of the lower portion of the second expandable tubular member by the first adjustable expansion mandrel, displacing the first adjustable expansion mandrel and the second adjustable expansion mandrel downwardly relative to the second expandable tubular member, decreasing the outside dimension of the first adjustable expansion mandrel and increasing the outside dimension of the second adjustable expansion mandrel, displacing the second adjustable expansion mandrel upwardly relative to the second expandable tubular member to radially expand and plastically deform portions of the second expandable tubular member above the lower portion of the second expandable tubular member, and pressurizing an interior region of the second expandable tubular member above the second adjustable expansion mandrel during the radial expansion of the portions of the second expandable tubular member above the lower portion of the second expandable tubular member by the second adjustable expansion mandrel. The outside dimension of the first adjustable expansion mandrel is greater than the outside dimension of the second adjustable expansion mandrel.

[0203] An apparatus for radially expanding and plastically deforming an expandable tubular member has been described that includes a support member, a locking device coupled to the support member and releasably coupled to the expandable tubular member, an adjustable expansion mandrel adapted to be controllably expanded to a larger outside dimension for radial expansion and plastic deformation of the expandable tubular member or collapsed to a smaller outside dimension, and an

actuator coupled to the locking member and the adjustable expansion mandrel adapted to displace the adjustable expansion mandrel upwardly through the expandable tubular member to radially expand and plastically deform a portion of the expandable tubular member. In an exemplary embodiment, the apparatus further includes a gripping assembly coupled to the support member and the actuator for controllably gripping at least one of the expandable tubular member or another tubular member. In an exemplary embodiment, the apparatus further includes one or more cup seals coupled to the support member for sealingly engaging the expandable tubular member above the adjustable expansion mandrel. In an exemplary embodiment, the apparatus further includes an expansion mandrel coupled to the adjustable expansion mandrel, and a float collar assembly coupled to the adjustable expansion mandrel that includes a float valve assembly and a sealing sleeve coupled to the float valve assembly adapted to be radially expanded and plastically deformed by the expansion mandrel.

[0204] A method for radially expanding and plastically deforming an expandable tubular member within a borehole has also been described that includes supporting the expandable tubular member, an hydraulic actuator, and an adjustable expansion mandrel within the borehole, increasing the size of the adjustable expansion mandrel, and displacing the adjustable expansion mandrel upwardly relative to the expandable tubular member using the hydraulic actuator to radially expand and plastically deform a portion of the expandable tubular member. In an exemplary embodiment, the method further includes reducing the size of the adjustable expansion mandrel after the portion of the expandable tubular member has been radially expanded and plastically deformed. In an exemplary embodiment, the method further includes fluidically sealing the radially expanded and plastically deformed end of the expandable tubular member after reducing the size of the adjustable expansion mandrel. In an exemplary embodiment, the method further includes permitting the position of the expandable tubular member to float relative to the position of the hydraulic actuator after fluidically sealing the radially expanded and plastically deformed end of the expandable tubular member. In an exemplary embodiment, the method further includes injecting a hardenable fluidic sealing material into an annulus between the expandable tubular member and a preexisting structure after permitting the position of the expandable tubular member to float relative to the position of the hydraulic actuator. In an exemplary embodiment, the method further includes increasing the size of the adjustable expansion mandrel after permitting the position of the expandable tubular member to float relative to the position of the hydraulic actuator. In an exemplary embodiment, the method further includes displacing the adjustable expansion cone upwardly relative to the expandable tubular member to radially expand and plastically deform another portion of the expandable tubular member. In an exemplary embodiment, the method further includes if the end of the other portion of the expandable tubular member overlaps with a preexisting structure, then not permitting the position of the expandable tubular member to float relative to the position of the hydraulic actuator, and displacing the adjustable expansion cone upwardly relative to the expandable tubular member using the hydraulic actuator to radially expand and plastically

deform the end of the other portion of the expandable tubular member that overlaps with the preexisting structure.

[0205] A method for forming a mono diameter wellbore casing within a borehole that includes a preexisting wellbore casing has been described that includes supporting the expandable tubular member, an hydraulic actuator, and an adjustable expansion mandrel within the borehole, increasing the size of the adjustable expansion mandrel, displacing the adjustable expansion mandrel upwardly relative to the expandable tubular member using the hydraulic actuator to radially expand and plastically deform a portion of the expandable tubular member, and displacing the adjustable expansion mandrel upwardly relative to the expandable tubular member to radially expand and plastically deform the remaining portion of the expandable tubular member and a portion of the preexisting wellbore casing that overlaps with an end of the remaining portion of the expandable tubular member. In an exemplary embodiment, the method further includes reducing the size of the adjustable expansion mandrel after the portion of the expandable tubular member has been radially expanded and plastically deformed. In an exemplary embodiment, the method further includes fluidically sealing the radially expanded and plastically deformed end of the expandable tubular member after reducing the size of the adjustable expansion mandrel. In an exemplary embodiment, the method further includes permitting the position of the expandable tubular member to float relative to the position of the hydraulic actuator after fluidically sealing the radially expanded and plastically deformed end of the expandable tubular member. In an exemplary embodiment, the method further includes injecting a hardenable fluidic sealing material into an annulus between the expandable tubular member and the borehole after permitting the position of the expandable tubular member to float relative to the position of the hydraulic actuator. In an exemplary embodiment, the method further includes increasing the size of the adjustable expansion mandrel after permitting the position of the expandable tubular member to float relative to the position of the hydraulic actuator. In an exemplary embodiment, the method further includes displacing the adjustable expansion cone upwardly relative to the expandable tubular member to radially expand and plastically deform the remaining portion of the expandable tubular member. In an exemplary embodiment, the method further includes not permitting the position of the expandable tubular member to float relative to the position of the hydraulic actuator, and displacing the adjustable expansion cone upwardly relative to the expandable tubular member using the hydraulic actuator to radially expand and plastically deform the end of the remaining portion of the expandable tubular member that overlaps with the preexisting wellbore casing after not permitting the position of the expandable tubular member to float relative to the position of the hydraulic actuator.

[0206] It is understood that variations may be made in the foregoing without departing from the scope of the invention. For example, the teachings of the present illustrative embodiments may be used to provide a wellbore casing, a pipeline, or a structural support. Furthermore, the elements and teachings of the various illustrative embodiments may be combined in whole or in part in some or all of the illustrative embodiments. In addition, the expansion surfaces of the upper and lower cone



segments, 600 and 602, may include any form of inclined surface or combination of inclined surfaces such as, for example, conical, spherical, elliptical, and/or parabolic that may or may not be faceted. Finally, one or more of the steps of the methods of operation of the exemplary embodiments may be omitted and/or performed in another order.

[0207] Although illustrative embodiments of the invention have been shown and described, a wide range of modification, changes and substitution is contemplated in the foregoing disclosure. In some instances, some features of the present invention may be employed without a corresponding use of the other features. Accordingly, it is appropriate that the appended claims be construed broadly and in a manner consistent with the scope of the invention.

## Claims

What is claimed is:

1. An apparatus for radially expanding and plastically deforming an expandable tubular member, comprising:
  - a float shoe adapted to mate with an end of the expandable tubular member;
  - an adjustable expansion mandrel coupled to the float shoe adapted to be controllably expanded to a larger outside dimension for radial expansion of the expandable tubular member or collapsed to a smaller outside dimension;
  - an actuator coupled to the adjustable expansion mandrel adapted to controllably displace the adjustable expansion mandrel relative to the expandable tubular member;
  - a locking device coupled to the actuator adapted to controllably engage the expandable tubular member; and
  - a support member coupled to the locking device.
  
2. A method for radially expanding and plastically deforming an expandable tubular member within a borehole, comprising:
  - positioning an adjustable expansion mandrel within the expandable tubular member;
  - supporting the expandable tubular member and the adjustable expansion mandrel within the borehole;
  - lowering the adjustable expansion mandrel out of the expandable tubular member;
  - increasing the outside dimension of the adjustable expansion mandrel; and
  - displacing the adjustable expansion mandrel upwardly relative to the expandable tubular member  $n$  times to radially expand and plastically deform  $n$  portions of the expandable tubular member.
  
3. A method for forming a mono diameter wellbore casing, comprising:
  - positioning an adjustable expansion mandrel within a first expandable tubular member;
  - supporting the first expandable tubular member and the adjustable expansion mandrel within a borehole;
  - lowering the adjustable expansion mandrel out of the first expandable tubular member;
  - increasing the outside dimension of the adjustable expansion mandrel;
  - displacing the adjustable expansion mandrel upwardly relative to the first expandable tubular member  $m$  times to radially expand and plastically deform  $m$  portions of the first expandable tubular member within the borehole;
  - positioning the adjustable expansion mandrel within a second expandable tubular member;

supporting the second expandable tubular member and the adjustable expansion mandrel within the borehole in overlapping relation to the first expandable tubular member; lowering the adjustable expansion mandrel out of the second expandable tubular member; increasing the outside dimension of the adjustable expansion mandrel; and displacing the adjustable expansion mandrel upwardly relative to the second expandable tubular member n times to radially expand and plastically deform n portions of the second expandable tubular member within the borehole.

4. An apparatus for radially expanding and plastically deforming an expandable tubular member, comprising:

a float shoe adapted to mate with an end of the expandable tubular member;  
an adjustable expansion mandrel coupled to the float shoe adapted to be controllably expanded to a larger outside dimension for radial expansion of the expandable tubular member or collapsed to a smaller outside dimension;  
an actuator coupled to the adjustable expansion mandrel adapted to controllably displace the adjustable expansion mandrel relative to the expandable tubular member;  
a locking device coupled to the actuator adapted to controllably engage the expandable tubular member;  
a support member coupled to the locking device; and  
a sealing member for sealingly engaging the expandable tubular member adapted to define a pressure chamber above the adjustable expansion mandrel during radial expansion of the expandable tubular member.

5. A method for radially expanding and plastically deforming an expandable tubular member within a borehole, comprising:

positioning an adjustable expansion mandrel within the expandable tubular member;  
supporting the expandable tubular member and the adjustable expansion mandrel within the borehole;  
lowering the adjustable expansion mandrel out of the expandable tubular member;  
increasing the outside dimension of the adjustable expansion mandrel;  
displacing the adjustable expansion mandrel upwardly relative to the expandable tubular member n times to radially expand and plastically deform n portions of the expandable tubular member within the borehole; and  
pressurizing an interior region of the expandable tubular member above the adjustable expansion mandrel during the radial expansion and plastic deformation of the expandable tubular member within the borehole.

6. A method for forming a minimum diameter wellbore casing, comprising:
- positioning an adjustable expansion mandrel within a first expandable tubular member;
  - supporting the first expandable tubular member and the adjustable expansion mandrel within a borehole;
  - lowering the adjustable expansion mandrel out of the first expandable tubular member;
  - increasing the outside dimension of the adjustable expansion mandrel;
  - displacing the adjustable expansion mandrel upwardly relative to the first expandable tubular member  $m$  times to radially expand and plastically deform  $m$  portions of the first expandable tubular member within the borehole;
  - pressurizing an interior region of the first expandable tubular member above the adjustable expansion mandrel during the radial expansion and plastic deformation of the first expandable tubular member within the borehole;
  - positioning the adjustable expansion mandrel within a second expandable tubular member;
  - supporting the second expandable tubular member and the adjustable expansion mandrel within the borehole in overlapping relation to the first expandable tubular member;
  - lowering the adjustable expansion mandrel out of the second expandable tubular member;
  - increasing the outside dimension of the adjustable expansion mandrel;
  - displacing the adjustable expansion mandrel upwardly relative to the second expandable tubular member  $n$  times to radially expand and plastically deform  $n$  portions of the second expandable tubular member within the borehole; and
  - pressurizing an interior region of the second expandable tubular member above the adjustable expansion mandrel during the radial expansion and plastic deformation of the second expandable tubular member within the borehole.
7. An apparatus for drilling a borehole within a subterranean formation and then radially expanding and plastically deforming an expandable tubular member within the drilled borehole, comprising:
- a float shoe adapted to mate with an end of the expandable tubular member;
  - a drilling member coupled to the float shoe adapted to drill the borehole;
  - an adjustable expansion mandrel coupled to the float shoe adapted to be controllably expanded to a larger outside dimension for radial expansion of the expandable tubular member or collapsed to a smaller outside dimension;
  - an actuator coupled to the adjustable expansion mandrel adapted to controllably displace the adjustable expansion mandrel relative to the expandable tubular member;

a locking device coupled to the actuator adapted to controllably engage the expandable tubular member; and  
a support member coupled to the locking device.

8. A method for drilling a borehole within a subterranean formation and then radially expanding and plastically deforming an expandable tubular member within the drilled borehole, comprising:  
positioning an adjustable expansion mandrel within the expandable tubular member;  
coupling a drilling member to an end of the expandable tubular member;  
drilling the borehole using the drilling member;  
positioning the adjustable expansion mandrel and the expandable tubular member within the drilled borehole;  
lowering the adjustable expansion mandrel out of the expandable tubular member;  
increasing the outside dimension of the adjustable expansion mandrel; and  
displacing the adjustable expansion mandrel upwardly relative to the expandable tubular member  $n$  times to radially expand and plastically deform  $n$  portions of the expandable tubular member within the drilled borehole.
9. A method for forming a mono diameter wellbore casing within a borehole, comprising:  
positioning an adjustable expansion mandrel within a first expandable tubular member;  
coupling a drilling member to an end of the first expandable tubular member;  
drilling a first section of the borehole using the drilling member;  
supporting the first expandable tubular member and the adjustable expansion mandrel within the drilled first section of the borehole;  
lowering the adjustable expansion mandrel out of the first expandable tubular member;  
increasing the outside dimension of the adjustable expansion mandrel;  
displacing the adjustable expansion mandrel upwardly relative to the first expandable tubular member  $m$  times to radially expand and plastically deform  $m$  portions of the first expandable tubular member within the drilled first section of the borehole;  
positioning the adjustable expansion mandrel within a second expandable tubular member;  
coupling the drilling member to an end of the second expandable tubular member;  
drilling a second section of the borehole using the drilling member;  
supporting the second expandable tubular member and the adjustable expansion mandrel within the borehole in overlapping relation to the first expandable tubular member within the second drilled section of the borehole;  
lowering the adjustable expansion mandrel out of the second expandable tubular member;  
increasing the outside dimension of the adjustable expansion mandrel; and

displacing the adjustable expansion mandrel upwardly relative to the second expandable tubular member  $n$  times to radially expand and plastically deform  $n$  portions of the second expandable tubular member within the drilled second section of the borehole.

10. An apparatus for drilling a borehole within a subterranean formation and then radially expanding and plastically deforming an expandable tubular member within the drilled borehole, comprising:
- a float shoe adapted to mate with an end of the expandable tubular member;
  - a drilling member coupled to the float shoe adapted to drill the borehole;
  - an adjustable expansion mandrel coupled to the float shoe adapted to be controllably expanded to a larger outside dimension for radial expansion of the expandable tubular member or collapsed to a smaller outside dimension;
  - an actuator coupled to the adjustable expansion mandrel adapted to controllably displace the adjustable expansion mandrel relative to the expandable tubular member;
  - a locking device coupled to the actuator adapted to controllably engage the expandable tubular member;
  - a support member coupled to the locking device; and
  - a sealing member for sealing engaging the expandable tubular member adapted to define a pressure chamber above the adjustable expansion mandrel during the radial expansion of the expandable tubular member.
11. A method for drilling a borehole within a subterranean formation and then radially expanding and plastically deforming an expandable tubular member within the drilled borehole, comprising:
- positioning an adjustable expansion mandrel within the expandable tubular member;
  - coupling a drilling member to an end of the expandable tubular member;
  - drilling the borehole using the drilling member;
  - positioning the adjustable expansion mandrel and the expandable tubular member within the drilled borehole;
  - lowering the adjustable expansion mandrel out of the expandable tubular member;
  - increasing the outside dimension of the adjustable expansion mandrel;
  - displacing the adjustable expansion mandrel upwardly relative to the expandable tubular member  $n$  times to radially expand and plastically deform  $n$  portions of the expandable tubular member within the drilled borehole; and
  - pressuring an interior portion of the expandable tubular member above the adjustable expansion mandrel during the radial expansion and plastic deformation of the expandable tubular member within the drilled borehole.

12. A method for forming a mono diameter wellbore casing within a borehole, comprising:  
positioning an adjustable expansion mandrel within a first expandable tubular member;  
coupling a drilling member to an end of the first expandable tubular member;  
drilling a first section of the borehole using the drilling member;  
supporting the first expandable tubular member and the adjustable expansion mandrel within the drilled first section of the borehole;  
lowering the adjustable expansion mandrel out of the first expandable tubular member;  
increasing the outside dimension of the adjustable expansion mandrel;  
displacing the adjustable expansion mandrel upwardly relative to the first expandable tubular member  $m$  times to radially expand and plastically deform  $m$  portions of the first expandable tubular member within the drilled first section of the borehole;  
pressuring an interior portion of the first expandable tubular member above the adjustable expansion mandrel during the radial expansion and plastic deformation of the first expandable tubular member within the first drilled section of the borehole;  
positioning the adjustable expansion mandrel within a second expandable tubular member;  
coupling the drilling member to an end of the second expandable tubular member;  
drilling a second section of the borehole using the drilling member;  
supporting the second expandable tubular member and the adjustable expansion mandrel within the borehole in overlapping relation to the first expandable tubular member within the second drilled section of the borehole;  
lowering the adjustable expansion mandrel out of the second expandable tubular member;  
increasing the outside dimension of the adjustable expansion mandrel;  
displacing the adjustable expansion mandrel upwardly relative to the second expandable tubular member  $n$  times to radially expand and plastically deform  $n$  portions of the second expandable tubular member within the drilled second section of the borehole; and  
pressuring an interior portion of the second expandable tubular member above the adjustable expansion mandrel during the radial expansion and plastic deformation of the second expandable tubular member within the drilled second section of the borehole.
13. An apparatus for radially expanding and plastically deforming an expandable tubular member, comprising:  
a float shoe adapted to mate with an end of the expandable tubular member;  
a first adjustable expansion mandrel coupled to the float shoe adapted to be controllably expanded to a first larger outside dimension for radial expansion of the expandable tubular member or collapsed to a first smaller outside dimension;

a second adjustable expansion mandrel coupled to the first adjustable expansion mandrel adapted to controllably expanded to a second larger outside dimension for radial expansion of the expandable tubular member or collapsed to a second smaller outside dimension;

an actuator coupled to the first and second adjustable expansion mandrels adapted to controllably displace the first and second adjustable expansion mandrels relative to the expandable tubular member;

a locking device coupled to the actuator adapted to controllably engage the expandable tubular member; and

a support member coupled to the locking device;

wherein the first larger outside dimension of the first adjustable expansion mandrel is larger than the second larger outside dimension of the second adjustable expansion mandrel.

14. A method for radially expanding and plastically deforming an expandable tubular member within a borehole, comprising:
- positioning first and second adjustable expansion mandrels within the expandable tubular member;
  - supporting the expandable tubular member and the first and second adjustable expansion mandrels within the borehole;
  - lowering the first adjustable expansion mandrel out of the expandable tubular member;
  - increasing the outside dimension of the first adjustable expansion mandrel;
  - displacing the first adjustable expansion mandrel upwardly relative to the expandable tubular member to radially expand and plastically deform a lower portion of the expandable tubular member;
  - displacing the first adjustable expansion mandrel and the second adjustable expansion mandrel downwardly relative to the expandable tubular member;
  - decreasing the outside dimension of the first adjustable expansion mandrel and increasing the outside dimension of the second adjustable expansion mandrel;
  - displacing the second adjustable expansion mandrel upwardly relative to the expandable tubular member to radially expand and plastically deform portions of the expandable tubular member above the lower portion of the expandable tubular member;
  - wherein the outside dimension of the first adjustable expansion mandrel is greater than the outside dimension of the second adjustable expansion mandrel.
15. A method for forming a mono diameter wellbore casing, comprising:



positioning first and second adjustable expansion mandrels within a first expandable tubular member;

supporting the first expandable tubular member and the first and second adjustable expansion mandrels within a borehole;

lowering the first adjustable expansion mandrel out of the first expandable tubular member;

increasing the outside dimension of the first adjustable expansion mandrel;

displacing the first adjustable expansion mandrel upwardly relative to the first expandable tubular member to radially expand and plastically deform a lower portion of the first expandable tubular member;

displacing the first adjustable expansion mandrel and the second adjustable expansion mandrel downwardly relative to the first expandable tubular member;

decreasing the outside dimension of the first adjustable expansion mandrel and increasing the outside dimension of the second adjustable expansion mandrel;

displacing the second adjustable expansion mandrel upwardly relative to the first expandable tubular member to radially expand and plastically deform portions of the first expandable tubular member above the lower portion of the expandable tubular member;

positioning first and second adjustable expansion mandrels within a second expandable tubular member;

supporting the first expandable tubular member and the first and second adjustable expansion mandrels within the borehole in overlapping relation to the first expandable tubular member;

lowering the first adjustable expansion mandrel out of the second expandable tubular member;

increasing the outside dimension of the first adjustable expansion mandrel;

displacing the first adjustable expansion mandrel upwardly relative to the second expandable tubular member to radially expand and plastically deform a lower portion of the second expandable tubular member;

displacing the first adjustable expansion mandrel and the second adjustable expansion mandrel downwardly relative to the second expandable tubular member;

decreasing the outside dimension of the first adjustable expansion mandrel and increasing the outside dimension of the second adjustable expansion mandrel; and

displacing the second adjustable expansion mandrel upwardly relative to the second expandable tubular member to radially expand and plastically deform portions of the second expandable tubular member above the lower portion of the second expandable tubular member;

wherein the outside dimension of the first adjustable expansion mandrel is greater than the outside dimension of the second adjustable expansion mandrel.

16. An apparatus for radially expanding and plastically deforming an expandable tubular member, comprising:

- a float shoe adapted to mate with an end of the expandable tubular member;
  - a first adjustable expansion mandrel coupled to the float shoe adapted to be controllably expanded to a first larger outside dimension for radial expansion of the expandable tubular member or collapsed to a first smaller outside dimension;
  - a second adjustable expansion mandrel coupled to the first adjustable expansion mandrel adapted to be controllably expanded to a second larger outside dimension for radial expansion of the expandable tubular member or collapsed to a second smaller outside dimension;
  - an actuator coupled to the first and second adjustable expansion mandrels adapted to controllably displace the first and second adjustable expansion mandrels relative to the expandable tubular member;
  - a locking device coupled to the actuator adapted to controllably engage the expandable tubular member;
  - a support member coupled to the locking device; and
  - a sealing member for sealingly engaging the expandable tubular adapted to define a pressure chamber above the first and second adjustable expansion mandrels during the radial expansion of the expandable tubular member;
- wherein the first larger outside dimension of the first adjustable expansion mandrel is larger than the second larger outside dimension of the second adjustable expansion mandrel.

17. A method for radially expanding and plastically deforming an expandable tubular member within a borehole, comprising:

- positioning first and second adjustable expansion mandrels within the expandable tubular member;
- supporting the expandable tubular member and the first and second adjustable expansion mandrels within the borehole;
- lowering the first adjustable expansion mandrel out of the expandable tubular member;
- increasing the outside dimension of the first adjustable expansion mandrel;
- displacing the first adjustable expansion mandrel upwardly relative to the expandable tubular member to radially expand and plastically deform a lower portion of the expandable tubular member;

pressurizing an interior region of the expandable tubular member above the first adjustable expansion mandrel during the radial expansion of the lower portion of the expandable tubular member by the first adjustable expansion mandrel;  
displacing the first adjustable expansion mandrel and the second adjustable expansion mandrel downwardly relative to the expandable tubular member;  
decreasing the outside dimension of the first adjustable expansion mandrel and increasing the outside dimension of the second adjustable expansion mandrel;  
displacing the second adjustable expansion mandrel upwardly relative to the expandable tubular member to radially expand and plastically deform portions of the expandable tubular member above the lower portion of the expandable tubular member; and  
pressurizing an interior region of the expandable tubular member above the second adjustable expansion mandrel during the radial expansion of the portions of the expandable tubular member above the lower portion of the expandable tubular member by the second adjustable expansion mandrel;  
wherein the outside dimension of the first adjustable expansion mandrel is greater than the outside dimension of the second adjustable expansion mandrel.

18. A method for forming a mono diameter wellbore casing, comprising:  
positioning first and second adjustable expansion mandrels within a first expandable tubular member;  
supporting the first expandable tubular member and the first and second adjustable expansion mandrels within a borehole;  
lowering the first adjustable expansion mandrel out of the first expandable tubular member;  
increasing the outside dimension of the first adjustable expansion mandrel;  
displacing the first adjustable expansion mandrel upwardly relative to the first expandable tubular member to radially expand and plastically deform a lower portion of the first expandable tubular member;  
pressurizing an interior region of the first expandable tubular member above the first adjustable expansion mandrel during the radial expansion of the lower portion of the first expandable tubular member by the first adjustable expansion mandrel;  
displacing the first adjustable expansion mandrel and the second adjustable expansion mandrel downwardly relative to the first expandable tubular member;  
decreasing the outside dimension of the first adjustable expansion mandrel and increasing the outside dimension of the second adjustable expansion mandrel;  
displacing the second adjustable expansion mandrel upwardly relative to the first expandable tubular member to radially expand and plastically deform portions of the first

expandable tubular member above the lower portion of the expandable tubular member;

pressurizing an interior region of the first expandable tubular member above the second adjustable expansion mandrel during the radial expansion of the portions of the first expandable tubular member above the lower portion of the first expandable tubular member by the second adjustable expansion mandrel;

positioning first and second adjustable expansion mandrels within a second expandable tubular member;

supporting the first expandable tubular member and the first and second adjustable expansion mandrels within the borehole in overlapping relation to the first expandable tubular member;

lowering the first adjustable expansion mandrel out of the second expandable tubular member;

increasing the outside dimension of the first adjustable expansion mandrel;

displacing the first adjustable expansion mandrel upwardly relative to the second expandable tubular member to radially expand and plastically deform a lower portion of the second expandable tubular member;

pressurizing an interior region of the second expandable tubular member above the first adjustable expansion mandrel during the radial expansion of the lower portion of the second expandable tubular member by the first adjustable expansion mandrel;

displacing the first adjustable expansion mandrel and the second adjustable expansion mandrel downwardly relative to the second expandable tubular member;

decreasing the outside dimension of the first adjustable expansion mandrel and increasing the outside dimension of the second adjustable expansion mandrel;

displacing the second adjustable expansion mandrel upwardly relative to the second expandable tubular member to radially expand and plastically deform portions of the second expandable tubular member above the lower portion of the second expandable tubular member; and

pressurizing an interior region of the second expandable tubular member above the second adjustable expansion mandrel during the radial expansion of the portions of the second expandable tubular member above the lower portion of the second expandable tubular member by the second adjustable expansion mandrel;

wherein the outside dimension of the first adjustable expansion mandrel is greater than the outside dimension of the second adjustable expansion mandrel.

19. An apparatus for radially expanding and plastically deforming an expandable tubular member, comprising:

a support member;

- a locking device coupled to the support member and releasably coupled to the expandable tubular member;
- an adjustable expansion mandrel adapted to be controllably expanded to a larger outside dimension for radial expansion and plastic deformation of the expandable tubular member or collapsed to a smaller outside dimension; and
- an actuator coupled to the locking member and the adjustable expansion mandrel adapted to displace the adjustable expansion mandrel upwardly through the expandable tubular member to radially expand and plastically deform a portion of the expandable tubular member.
20. The apparatus of claim 19, further comprising:  
a gripping assembly coupled to the support member and the actuator for controllably gripping at least one of the expandable tubular member or another tubular member.
21. The apparatus of claim 19, further comprising:  
one or more cup seals coupled to the support member for sealingly engaging the expandable tubular member above the adjustable expansion mandrel.
22. The apparatus of claim 19, further comprising:  
an expansion mandrel coupled to the adjustable expansion mandrel; and  
a float collar assembly coupled to the adjustable expansion mandrel comprising:  
a float valve assembly; and  
a sealing sleeve coupled to the float valve assembly adapted to be radially expanded and plastically deformed by the expansion mandrel.
23. A method for radially expanding and plastically deforming an expandable tubular member within a borehole, comprising:  
supporting the expandable tubular member, an hydraulic actuator, and an adjustable expansion mandrel within the borehole;  
increasing the size of the adjustable expansion mandrel; and  
displacing the adjustable expansion mandrel upwardly relative to the expandable tubular member using the hydraulic actuator to radially expand and plastically deform a portion of the expandable tubular member.
24. The method of claim 23, further comprising:

reducing the size of the adjustable expansion mandrel after the portion of the expandable tubular member has been radially expanded and plastically deformed.

25. The method of claim 24, further comprising:  
fluidically sealing the radially expanded and plastically deformed end of the expandable tubular member after reducing the size of the adjustable expansion mandrel.
26. The method of claim 25, further comprising:  
permitting the position of the expandable tubular member to float relative to the position of the hydraulic actuator after fluidically sealing the radially expanded and plastically deformed end of the expandable tubular member.
27. The method of claim 26, further comprising:  
injecting a hardenable fluidic sealing material into an annulus between the expandable tubular member and a preexisting structure after permitting the position of the expandable tubular member to float relative to the position of the hydraulic actuator.
28. The method of claim 26, further comprising:  
increasing the size of the adjustable expansion mandrel after permitting the position of the expandable tubular member to float relative to the position of the hydraulic actuator.
29. The method of claim 28, further comprising:  
displacing the adjustable expansion cone upwardly relative to the expandable tubular member to radially expand and plastically deform another portion of the expandable tubular member.
30. The method of claim 29, further comprising:  
if the end of the other portion of the expandable tubular member overlaps with a preexisting structure, then  
not permitting the position of the expandable tubular member to float relative to the position of the hydraulic actuator; and  
displacing the adjustable expansion cone upwardly relative to the expandable tubular member using the hydraulic actuator to radially expand and plastically deform the end of the other portion of the expandable tubular member that overlaps with the preexisting structure.

31. A method for forming a mono diameter wellbore casing within a borehole that includes a preexisting wellbore casing, comprising:  
supporting the expandable tubular member, an hydraulic actuator, and an adjustable expansion mandrel within the borehole;  
increasing the size of the adjustable expansion mandrel;  
displacing the adjustable expansion mandrel upwardly relative to the expandable tubular member using the hydraulic actuator to radially expand and plastically deform a portion of the expandable tubular member; and  
displacing the adjustable expansion mandrel upwardly relative to the expandable tubular member to radially expand and plastically deform the remaining portion of the expandable tubular member and a portion of the preexisting wellbore casing that overlaps with an end of the remaining portion of the expandable tubular member.
32. The method of claim 31, further comprising:  
reducing the size of the adjustable expansion mandrel after the portion of the expandable tubular member has been radially expanded and plastically deformed.
33. The method of claim 32, further comprising:  
fluidically sealing the radially expanded and plastically deformed end of the expandable tubular member after reducing the size of the adjustable expansion mandrel.
34. The method of claim 33, further comprising:  
permitting the position of the expandable tubular member to float relative to the position of the hydraulic actuator after fluidically sealing the radially expanded and plastically deformed end of the expandable tubular member.
35. The method of claim 34, further comprising:  
injecting a hardenable fluidic sealing material into an annulus between the expandable tubular member and the borehole after permitting the position of the expandable tubular member to float relative to the position of the hydraulic actuator.
36. The method of claim 34, further comprising:  
increasing the size of the adjustable expansion mandrel after permitting the position of the expandable tubular member to float relative to the position of the hydraulic actuator.
37. The method of claim 36, further comprising:

displacing the adjustable expansion cone upwardly relative to the expandable tubular member to radially expand and plastically deform the remaining portion of the expandable tubular member.

38. The method of claim 37, further comprising:  
not permitting the position of the expandable tubular member to float relative to the position of the hydraulic actuator; and  
displacing the adjustable expansion cone upwardly relative to the expandable tubular member using the hydraulic actuator to radially expand and plastically deform the end of the remaining portion of the expandable tubular member that overlaps with the preexisting wellbore casing after not permitting the position of the expandable tubular member to float relative to the position of the hydraulic actuator.



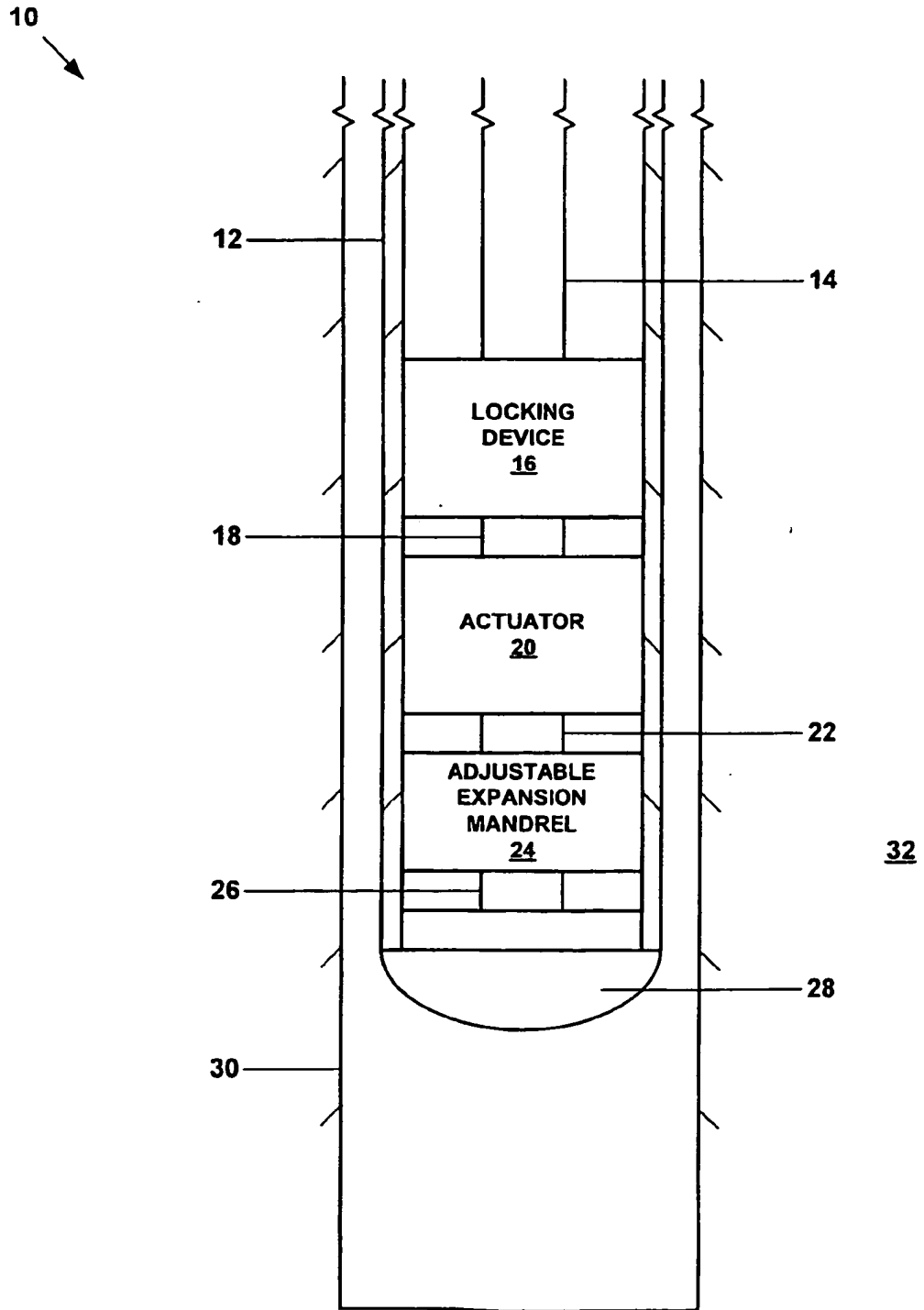

Fig. 1

10  
↙

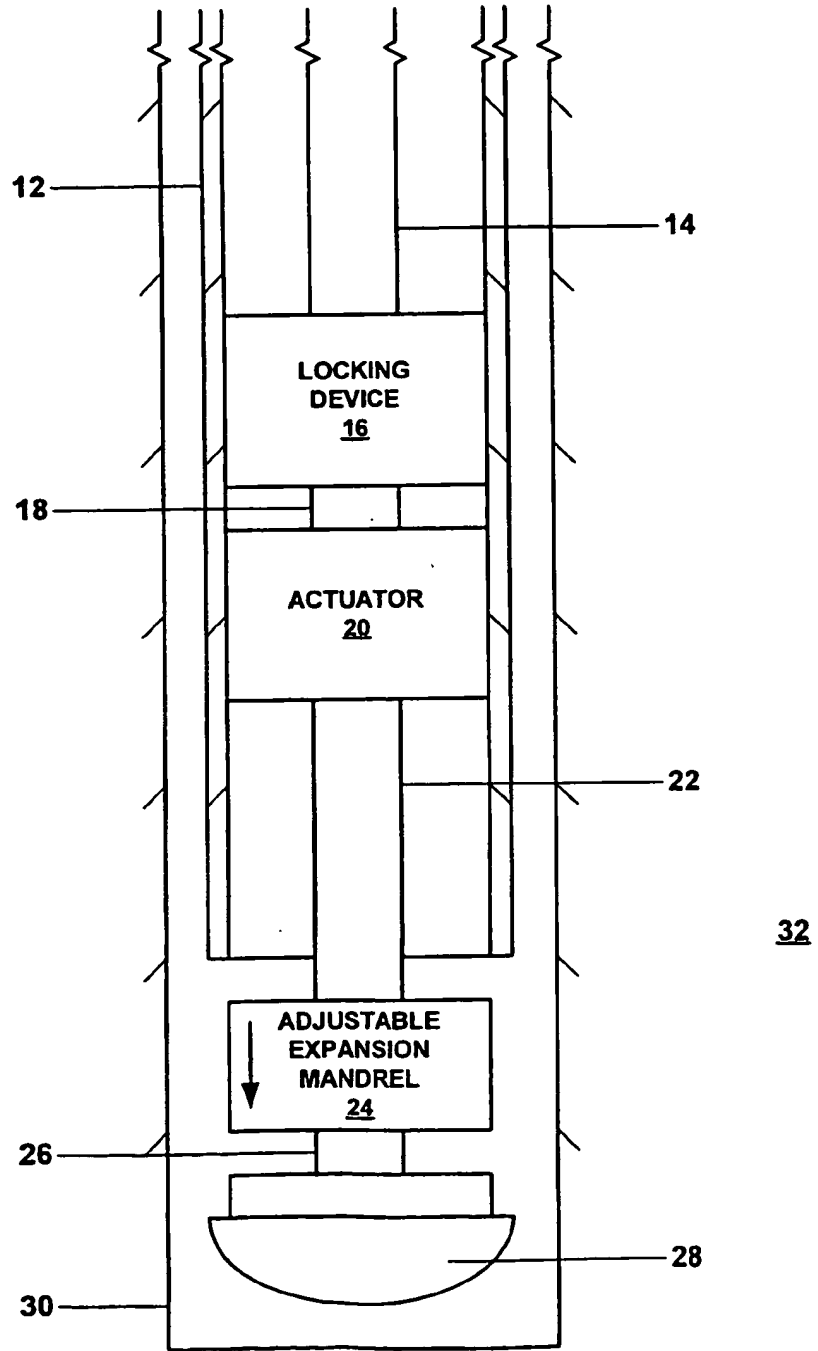

Fig. 2

10  
↙

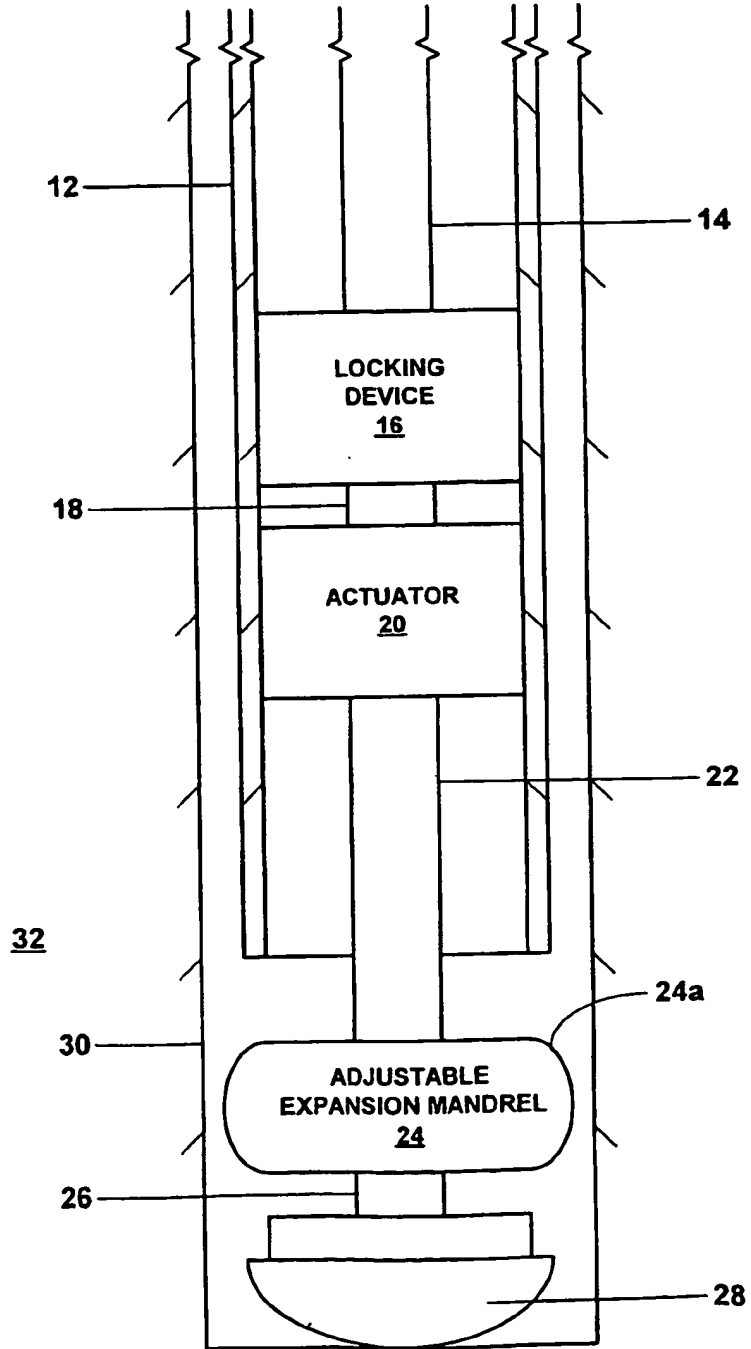

Fig. 3

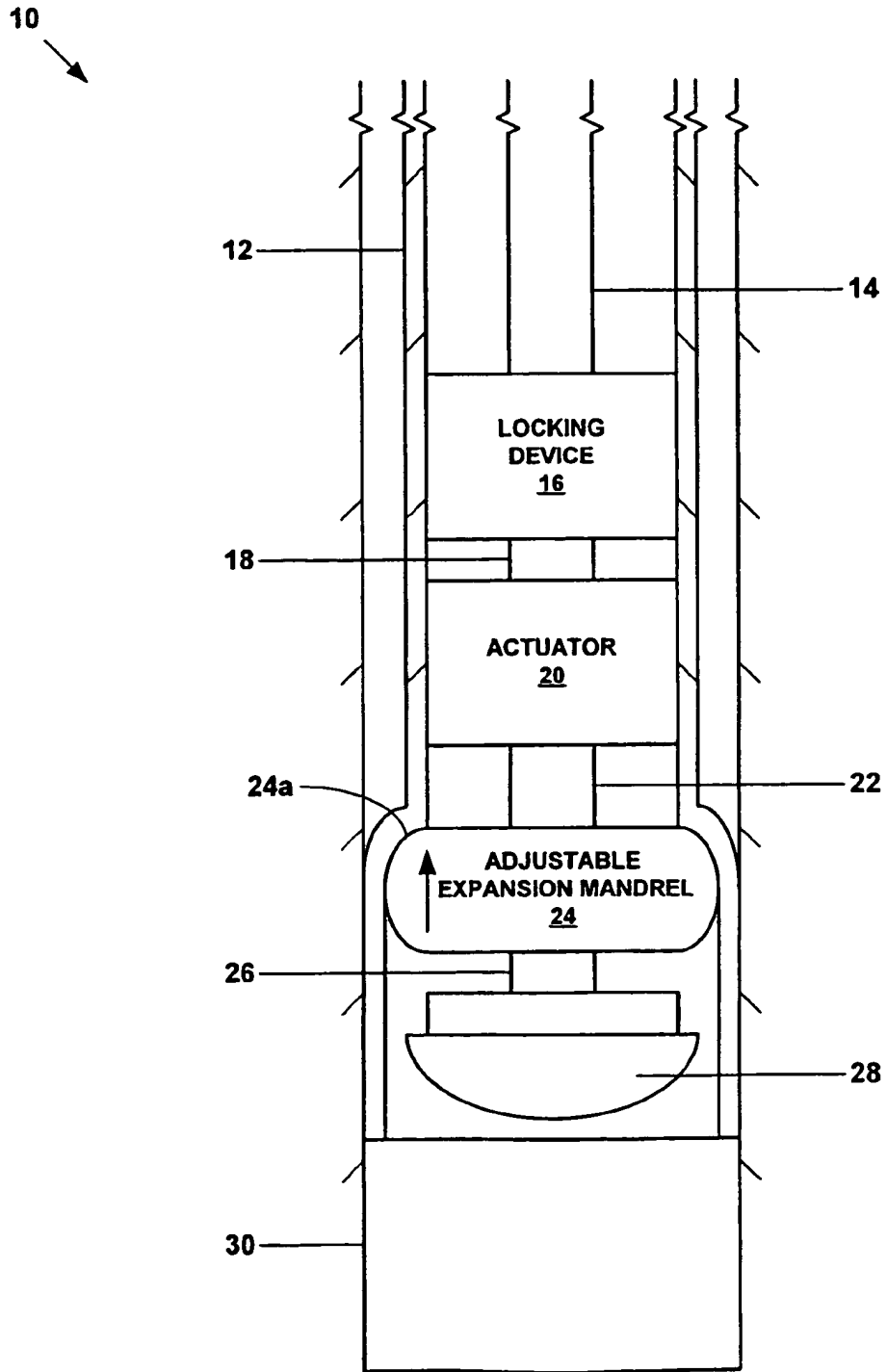

Fig. 4

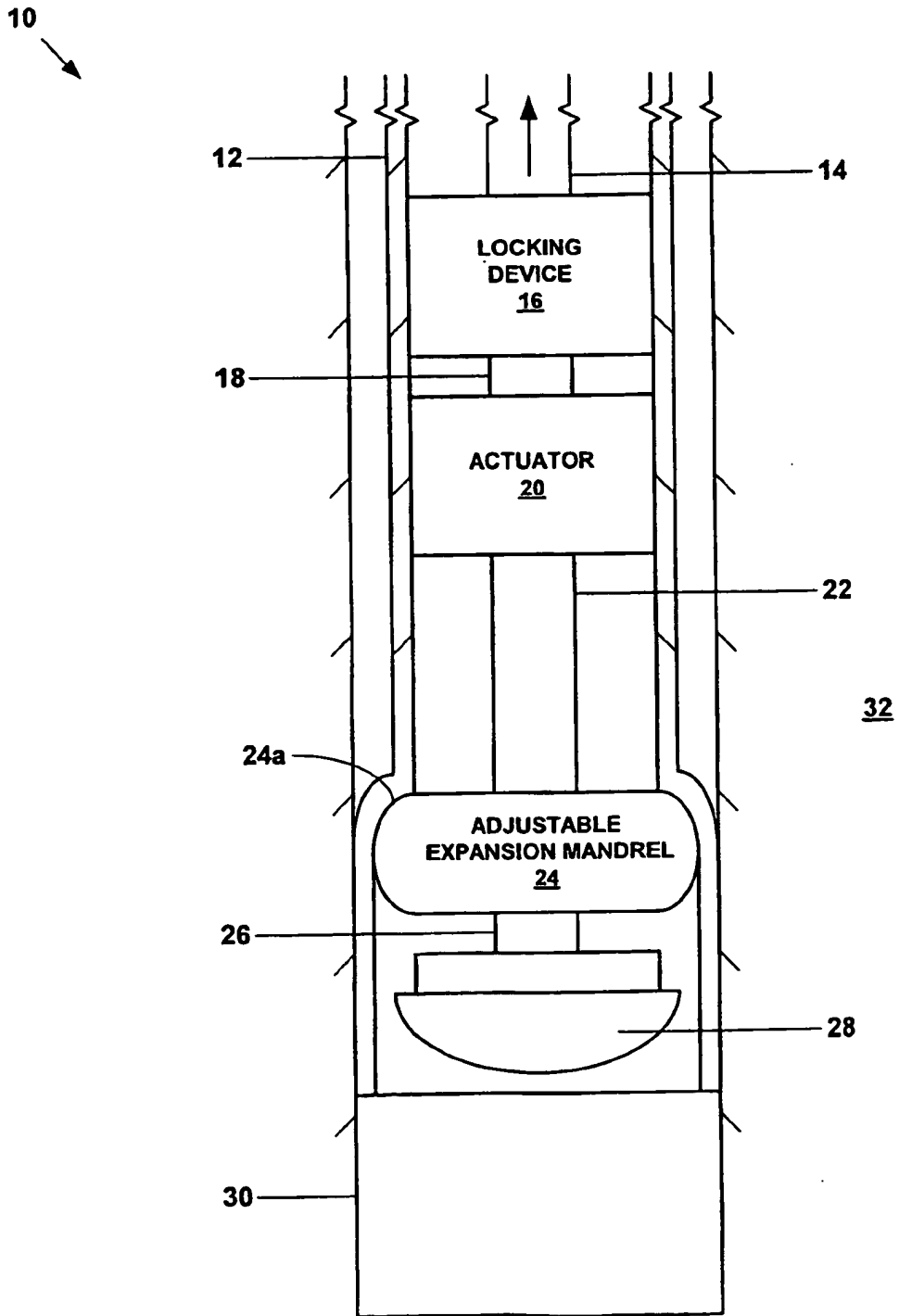

Fig. 5

10  
↙

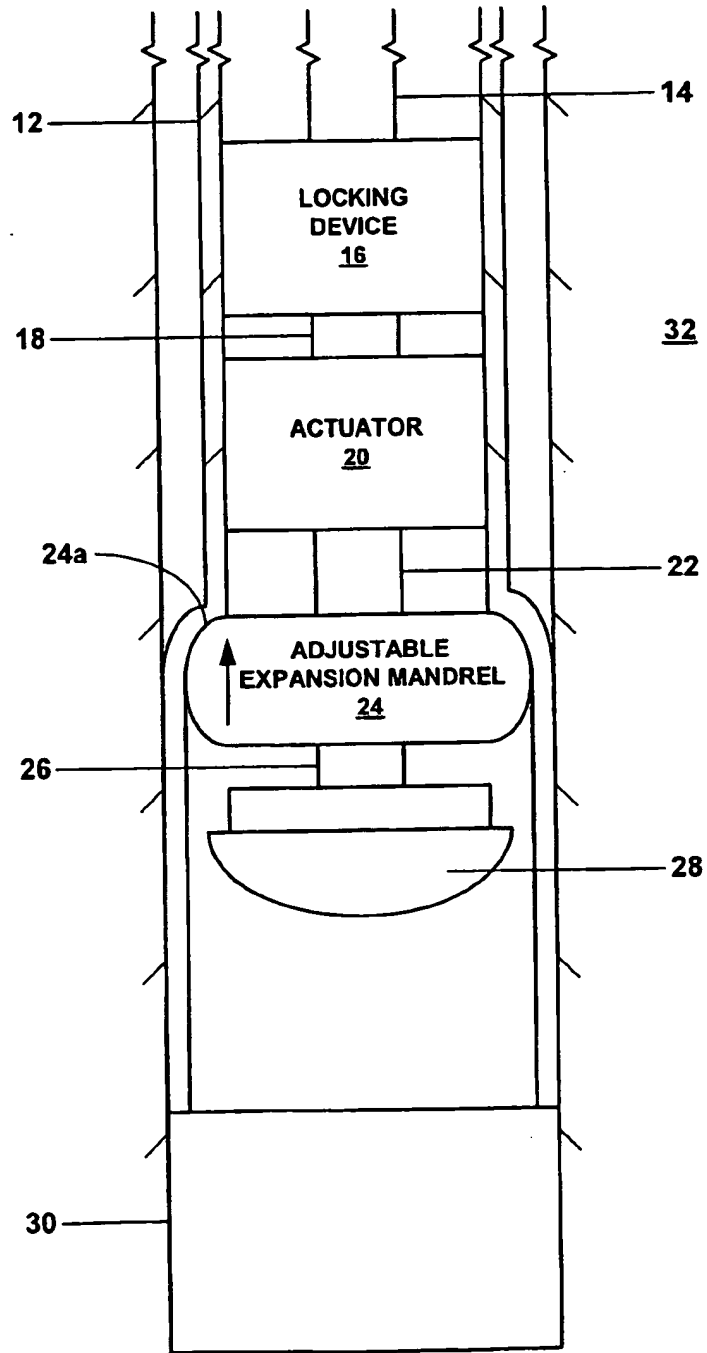

Fig. 6

10

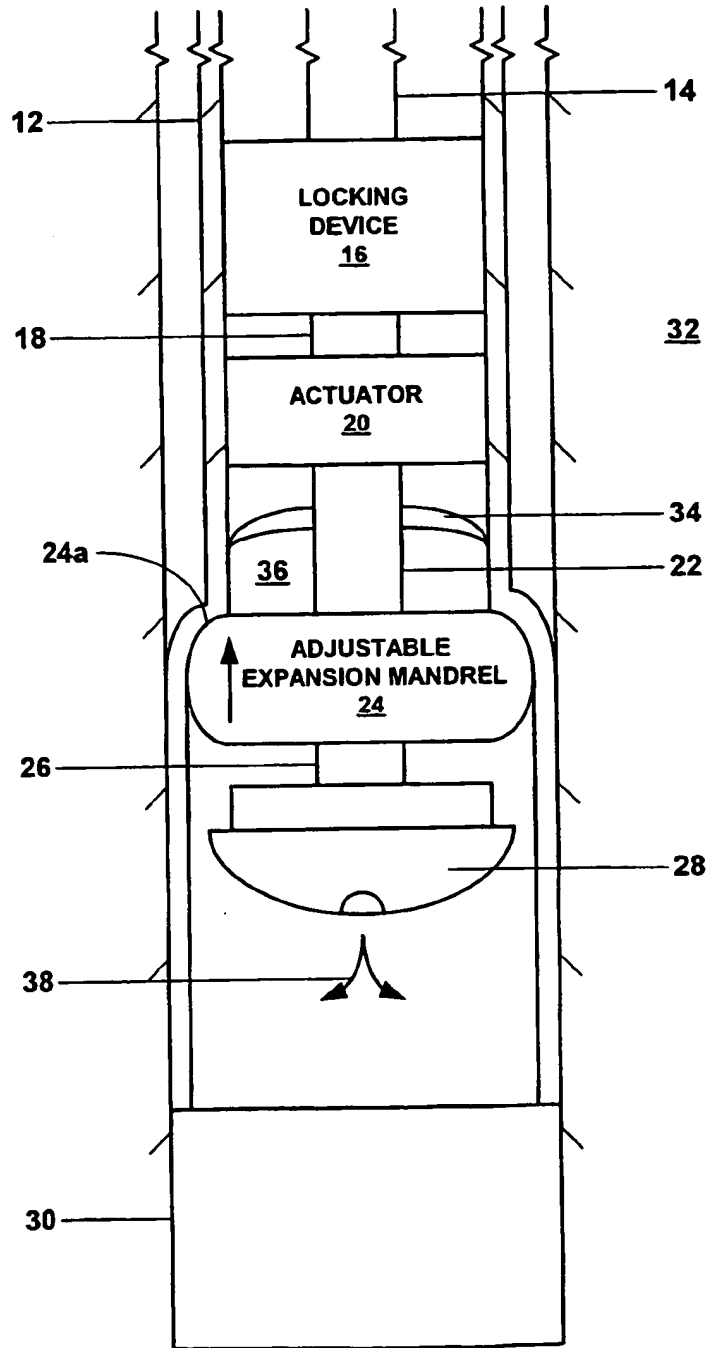

Fig. 6a

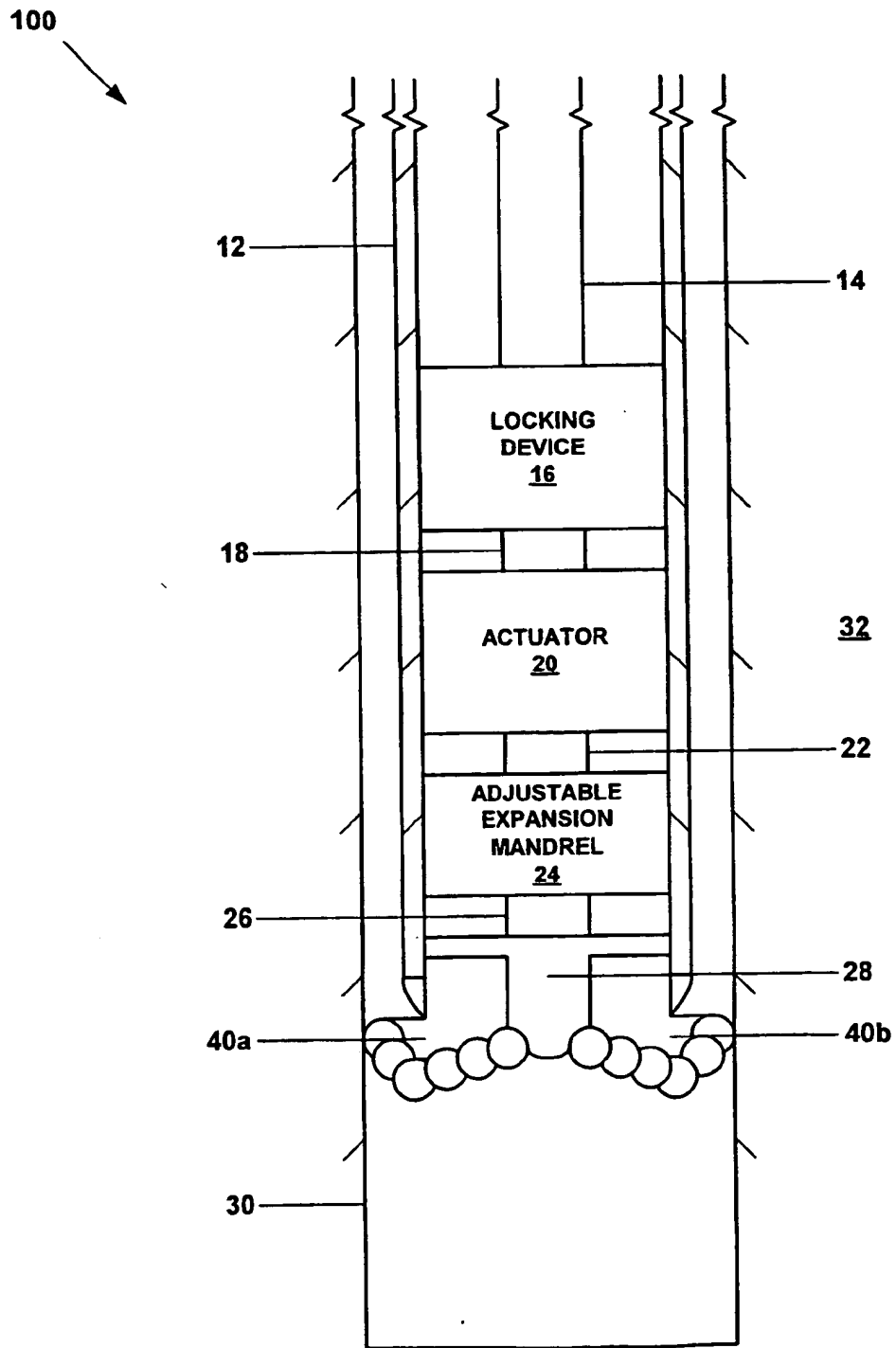

Fig. 7



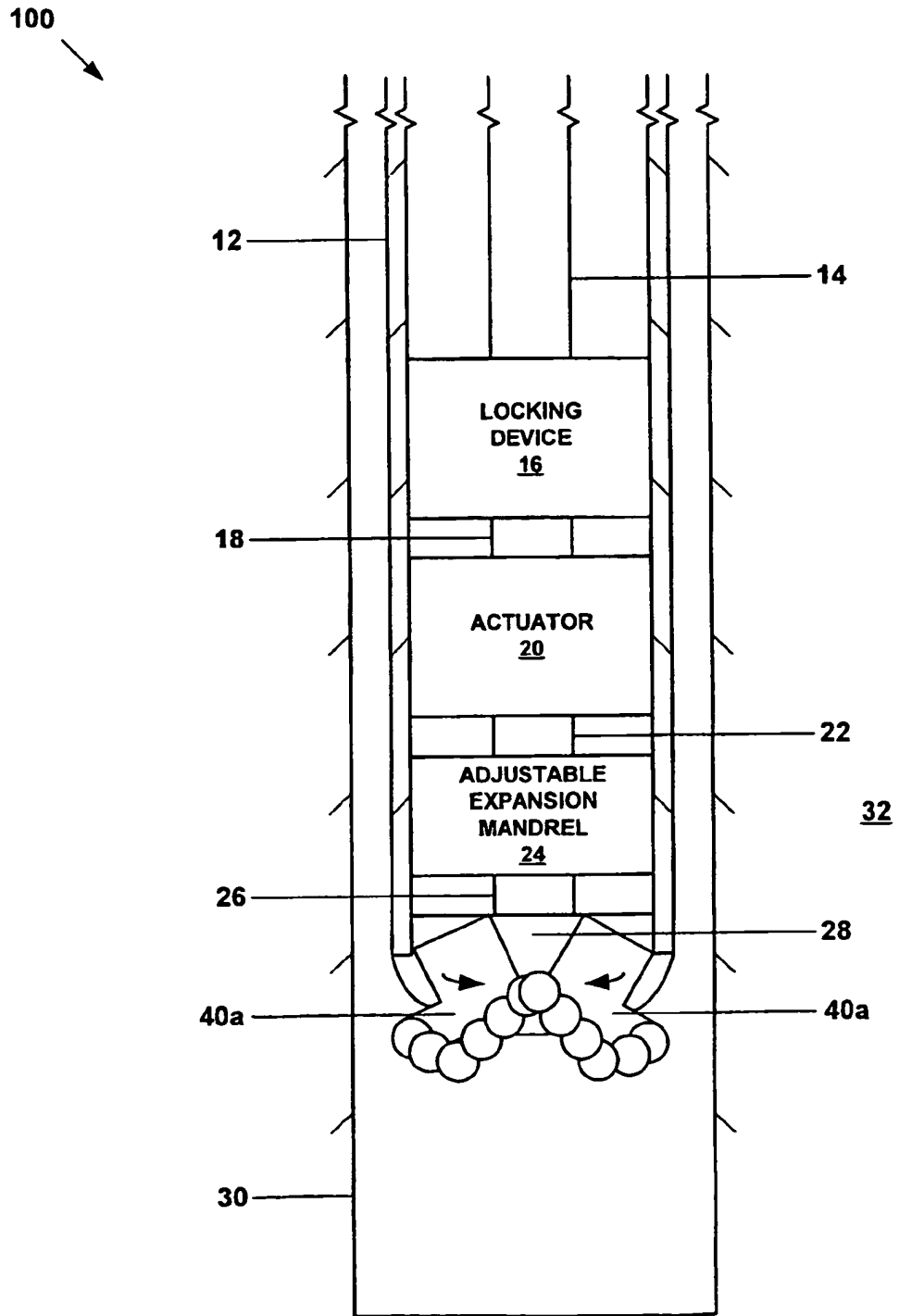

Fig. 8

100 ↘

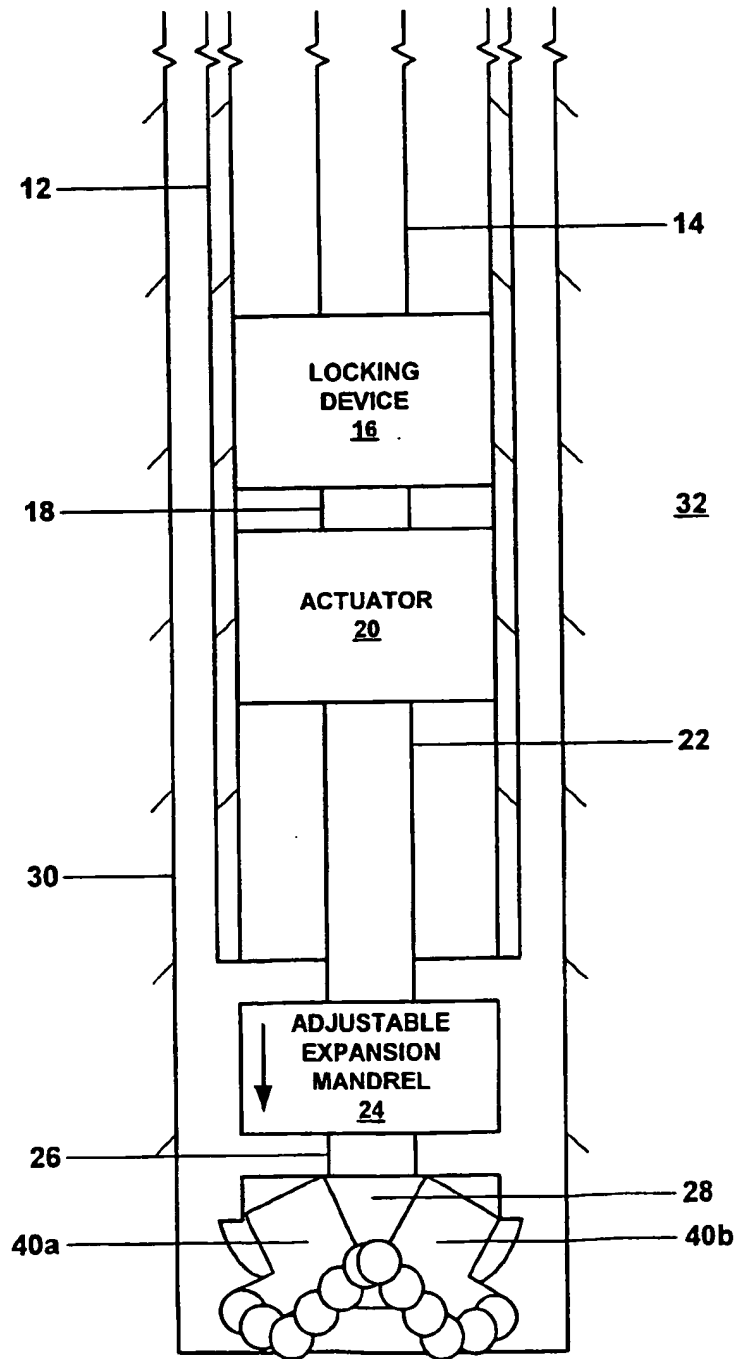

Fig. 9

100

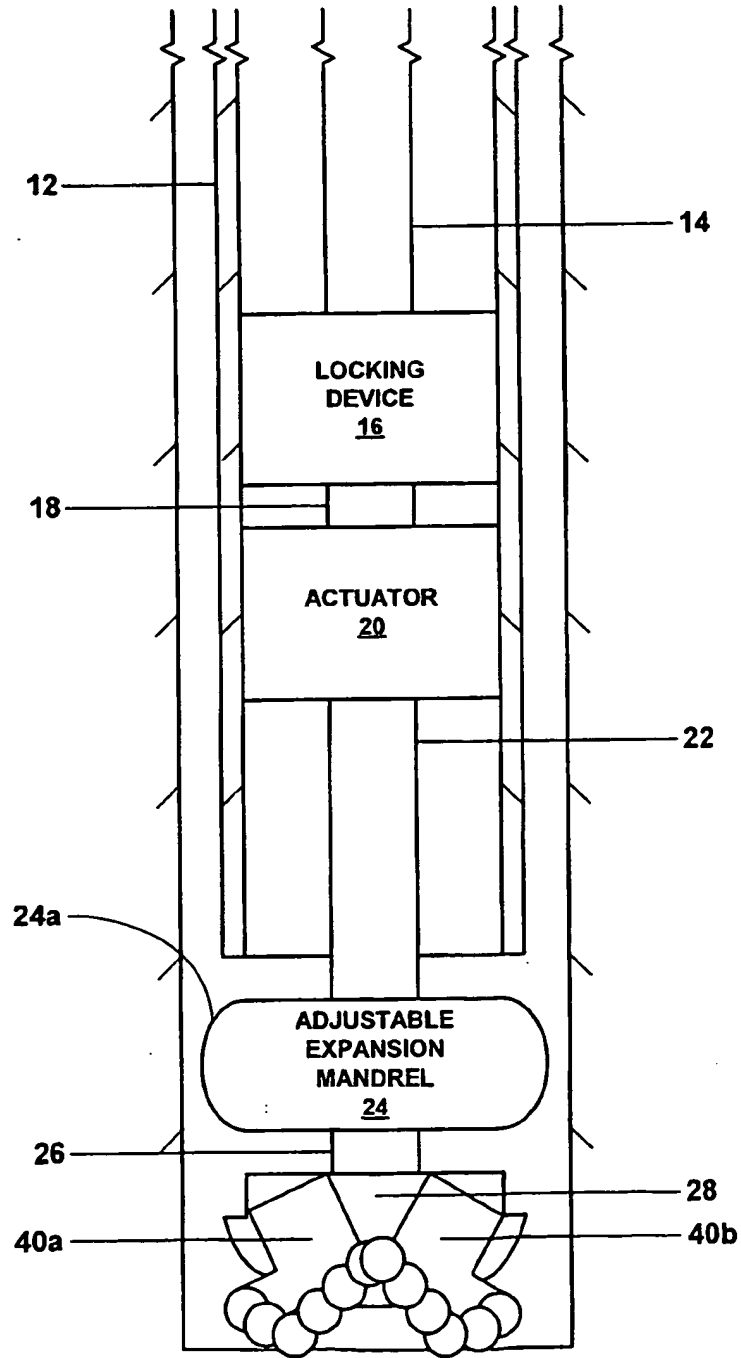

Fig. 10

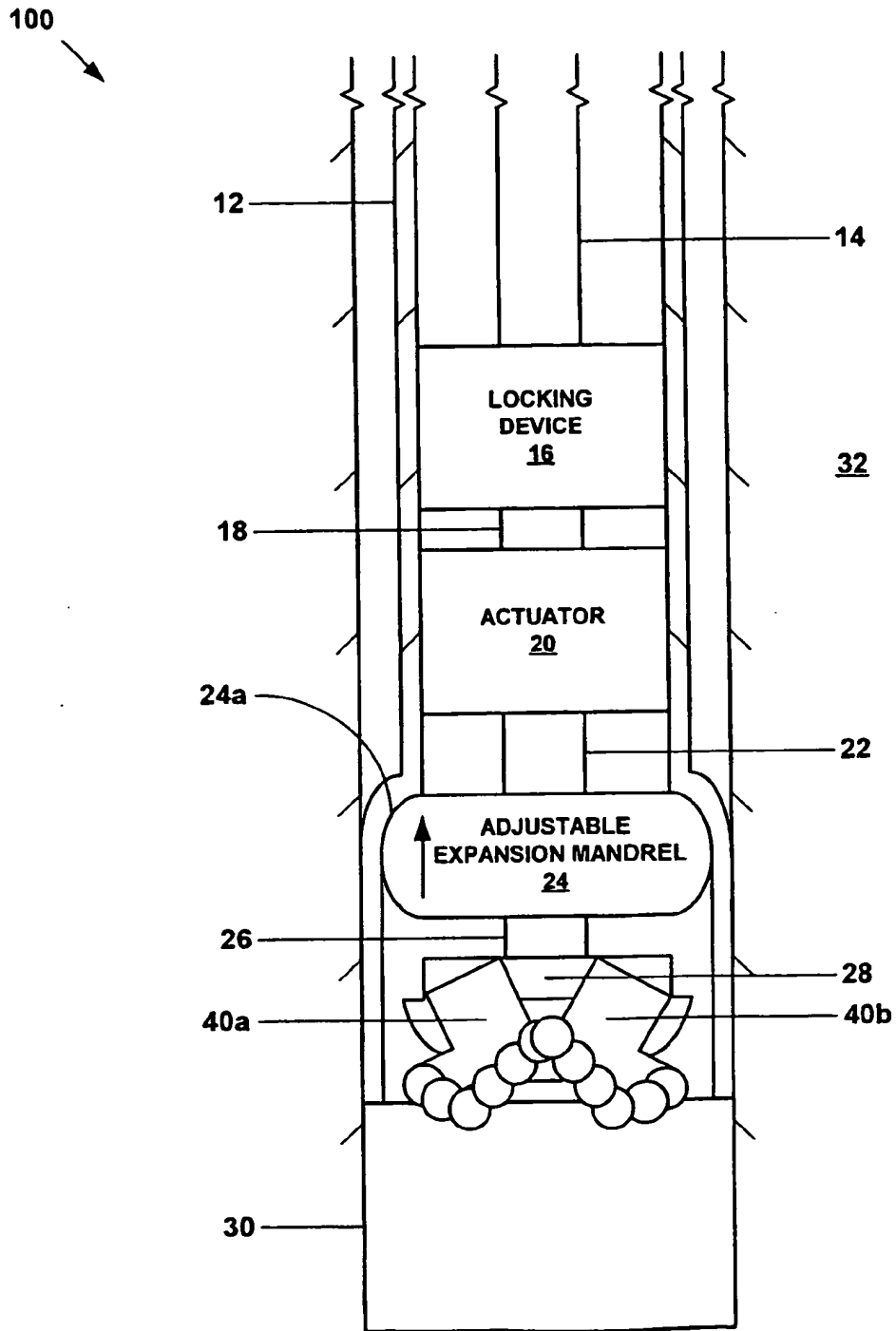

Fig. 11

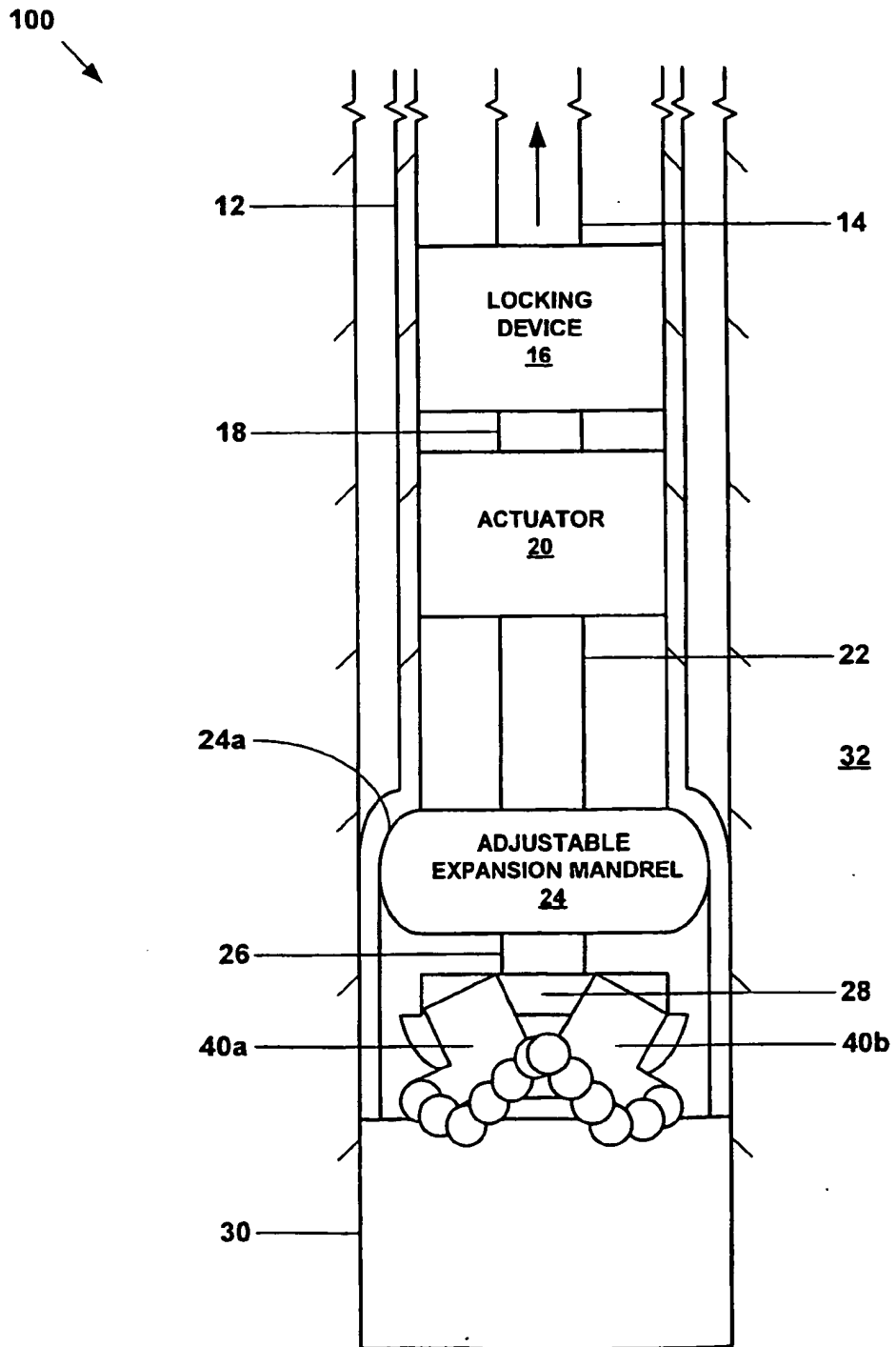

Fig. 12

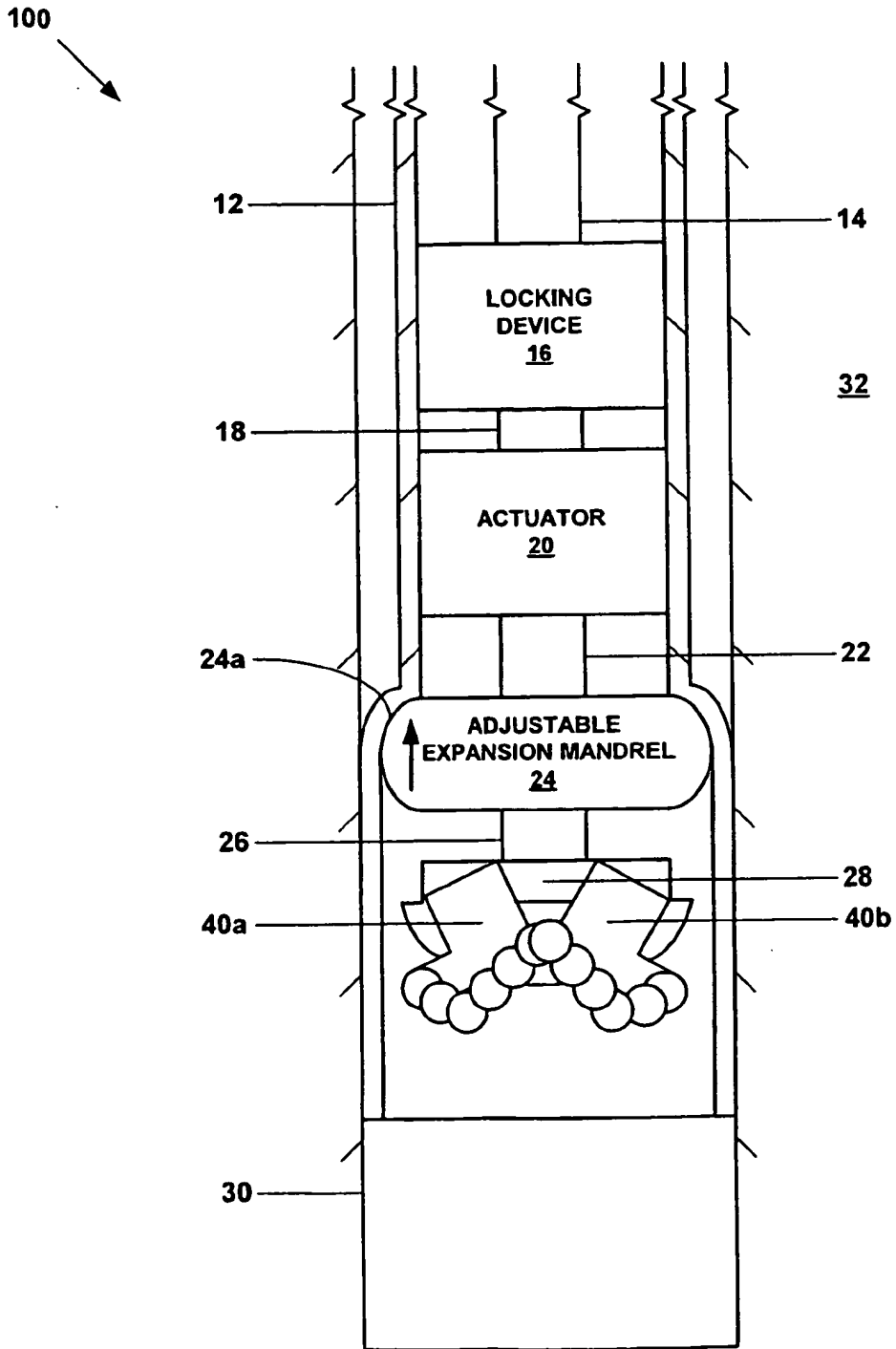

Fig. 13

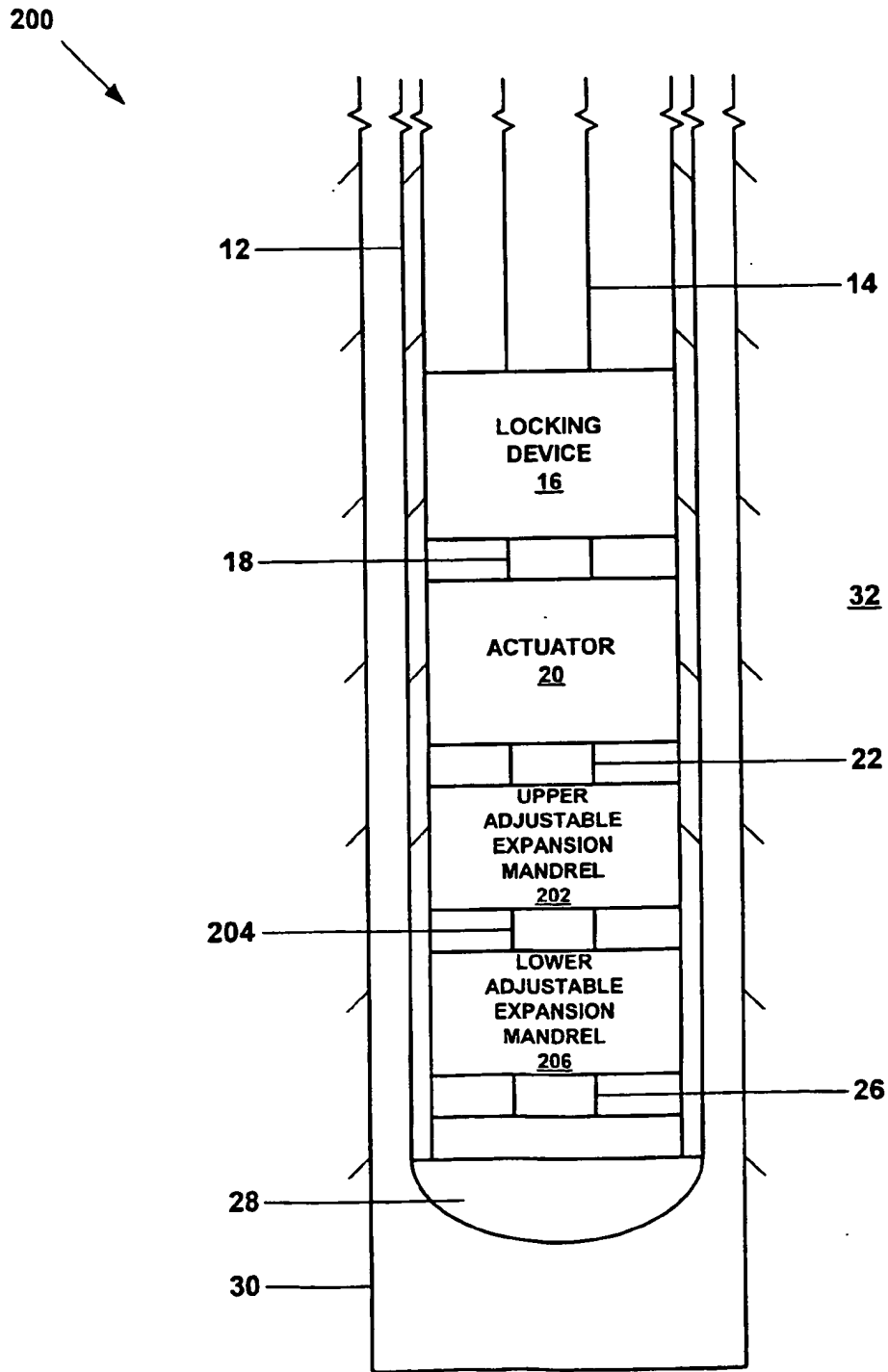

Fig. 14.

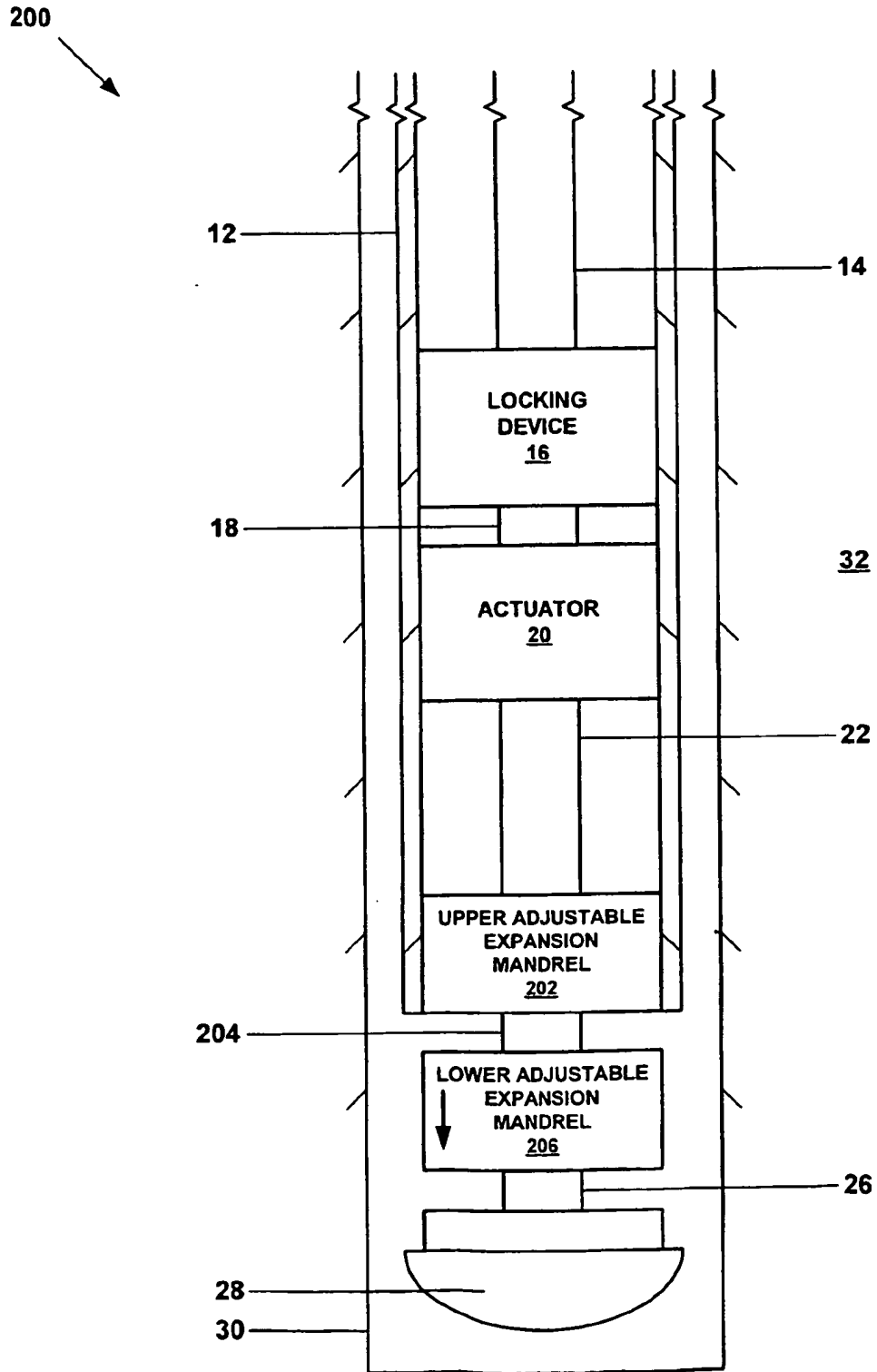

Fig. 15



200

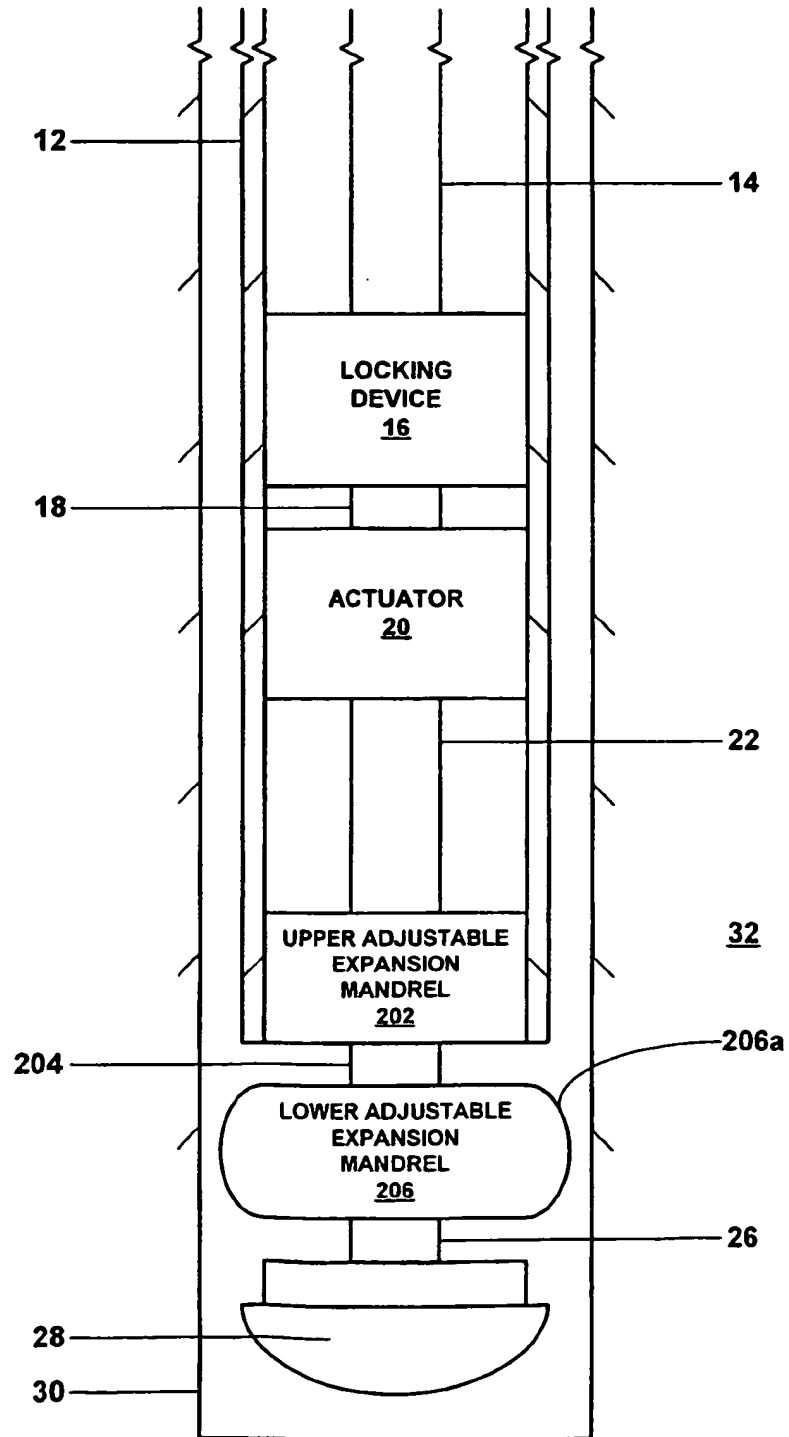

Fig. 16

200

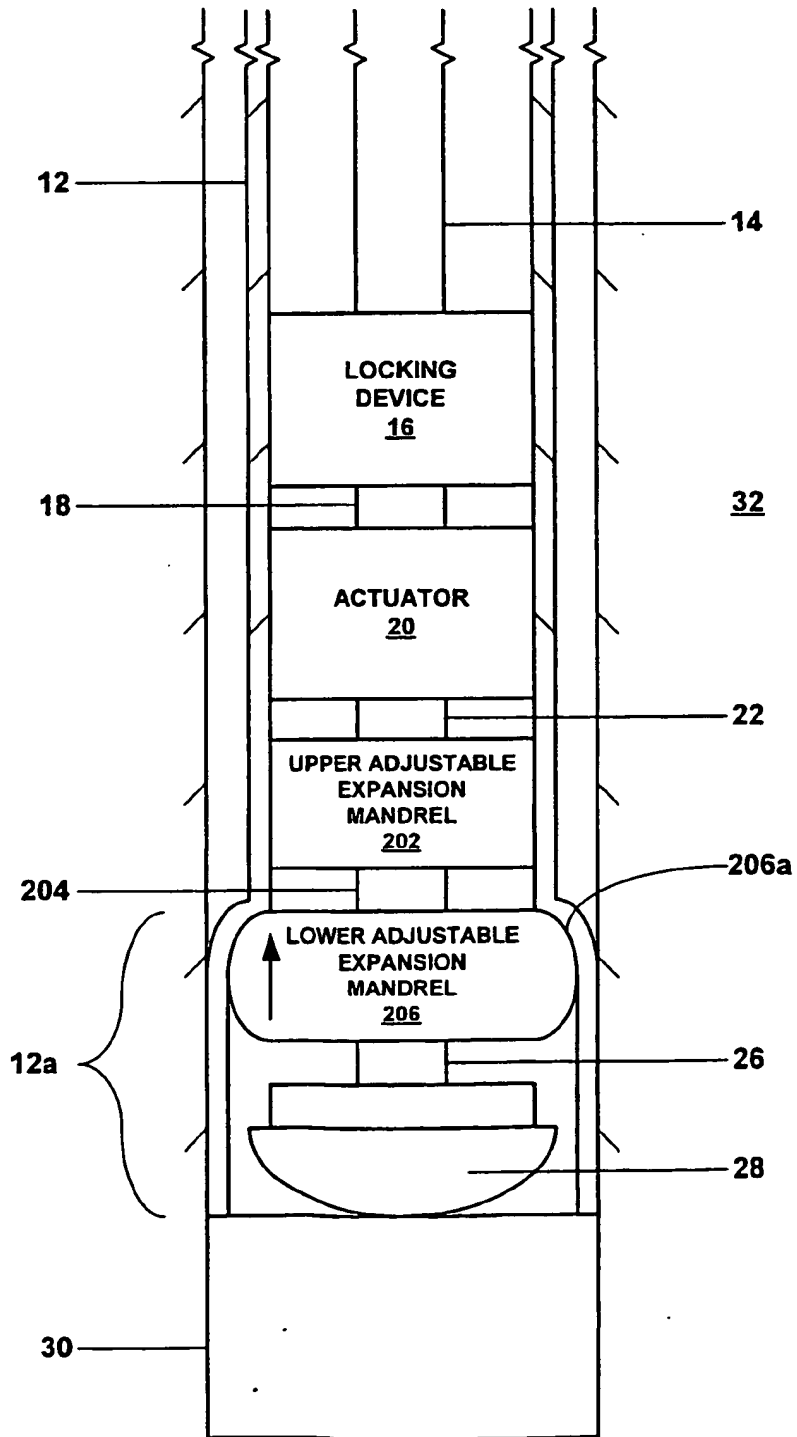

Fig. 17

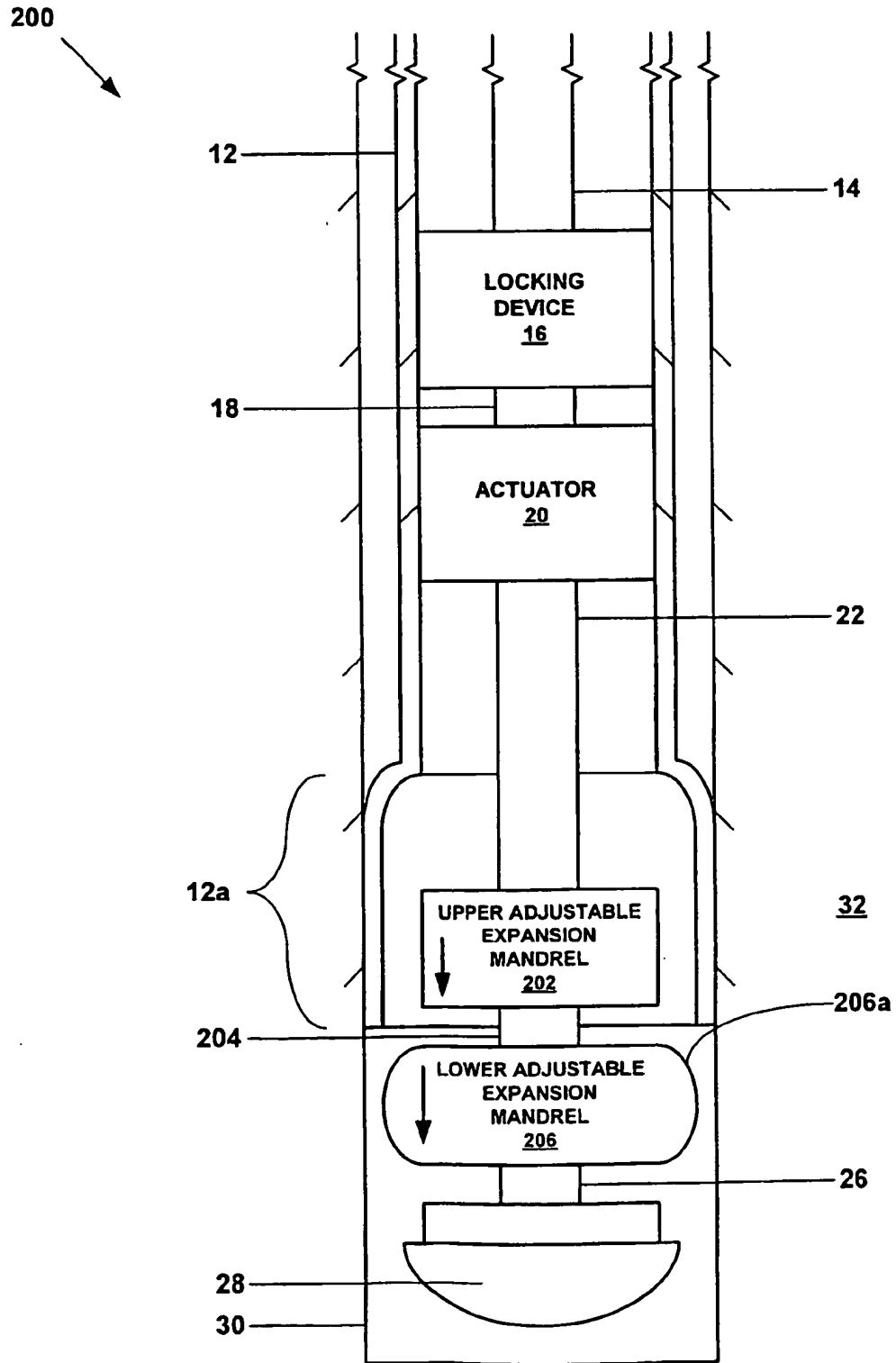

Fig. 18

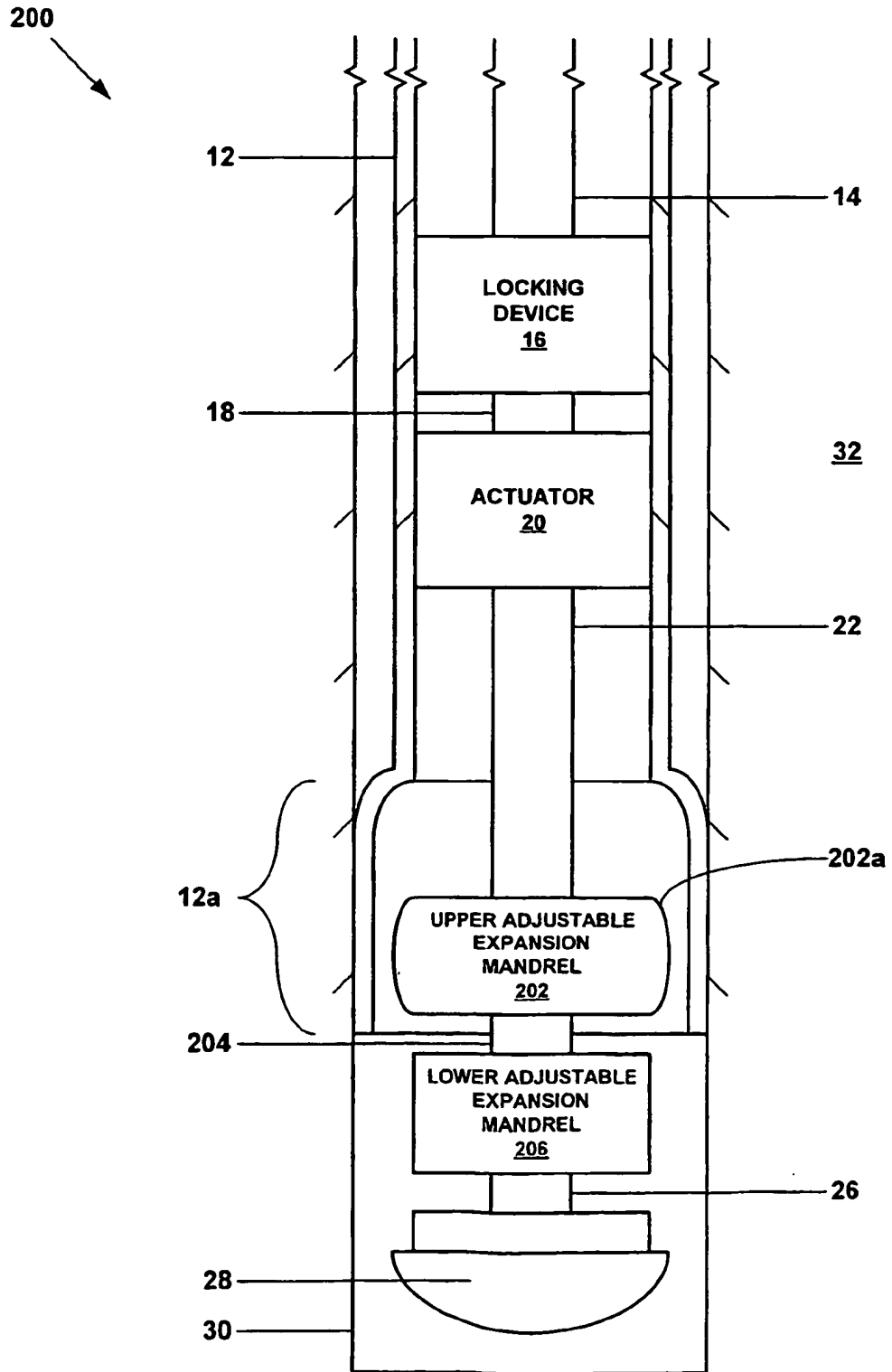

Fig. 19

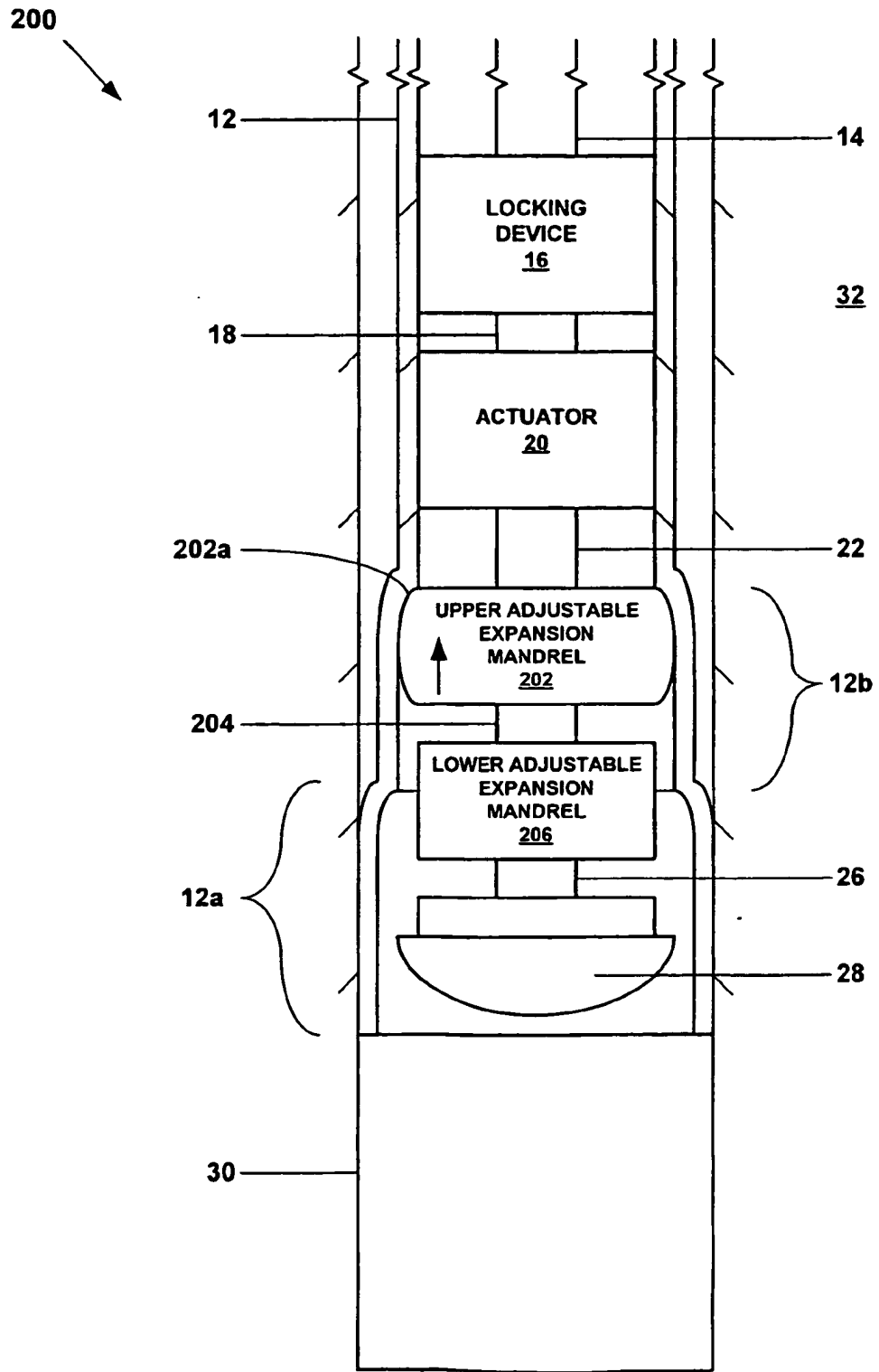

Fig. 20

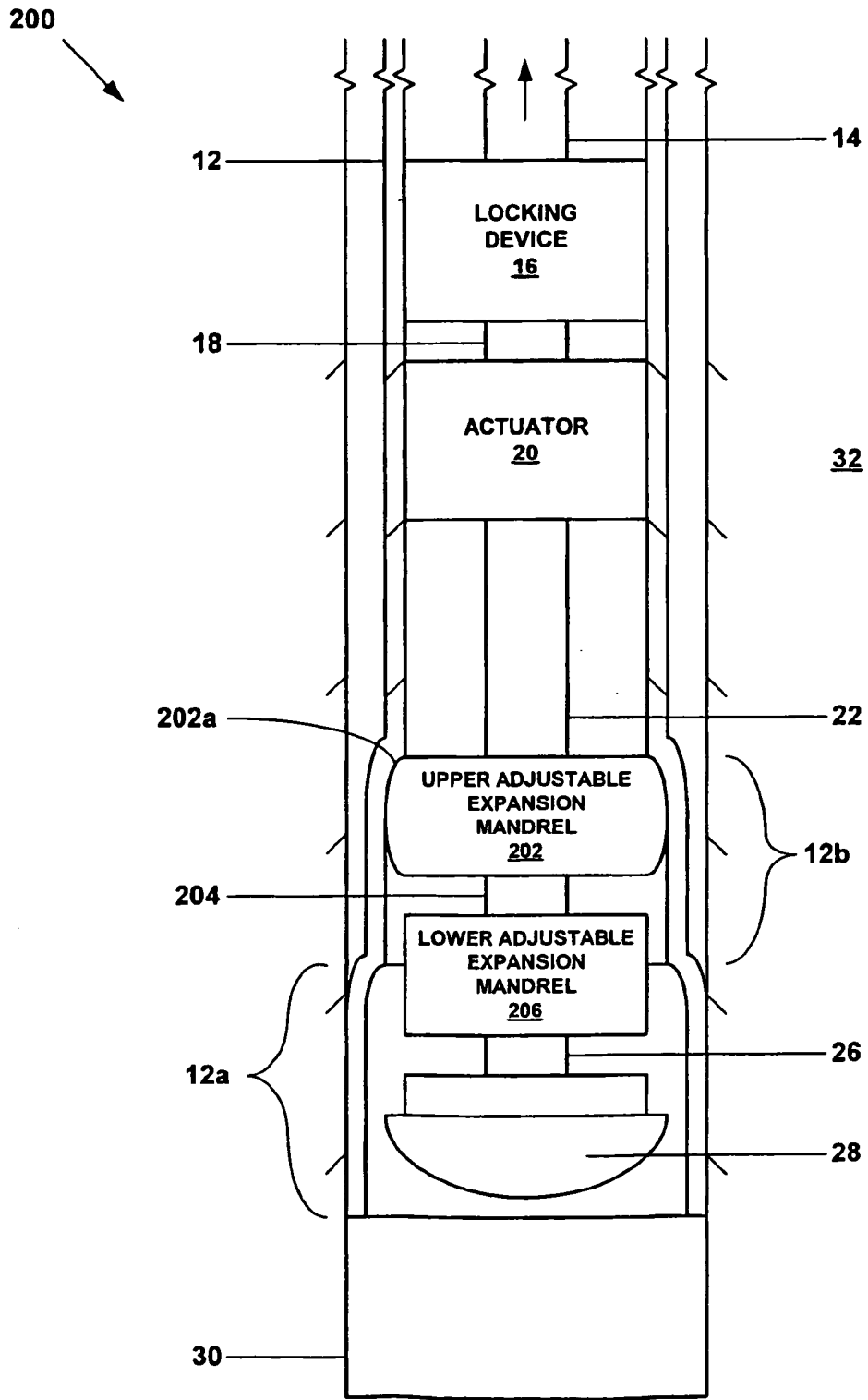

Fig. 21

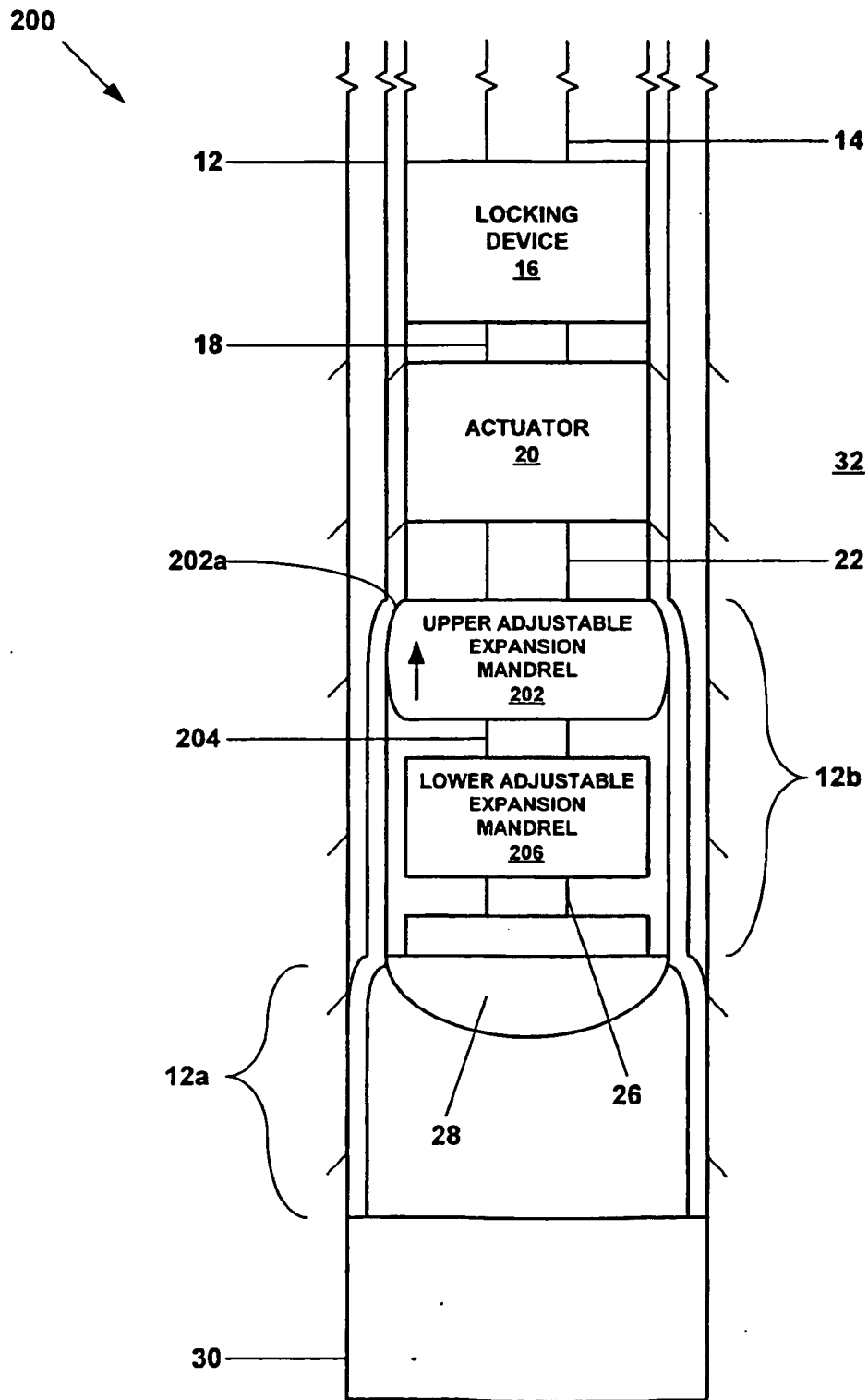

Fig. 22

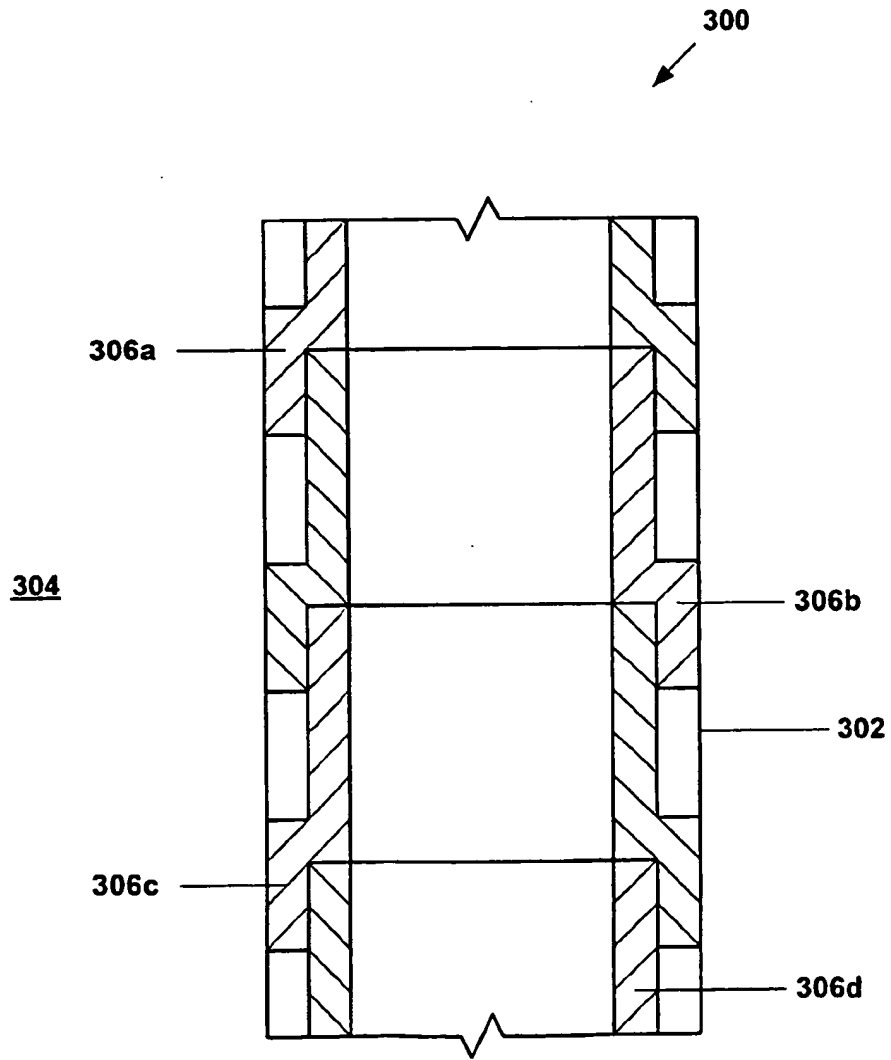

Fig. 23



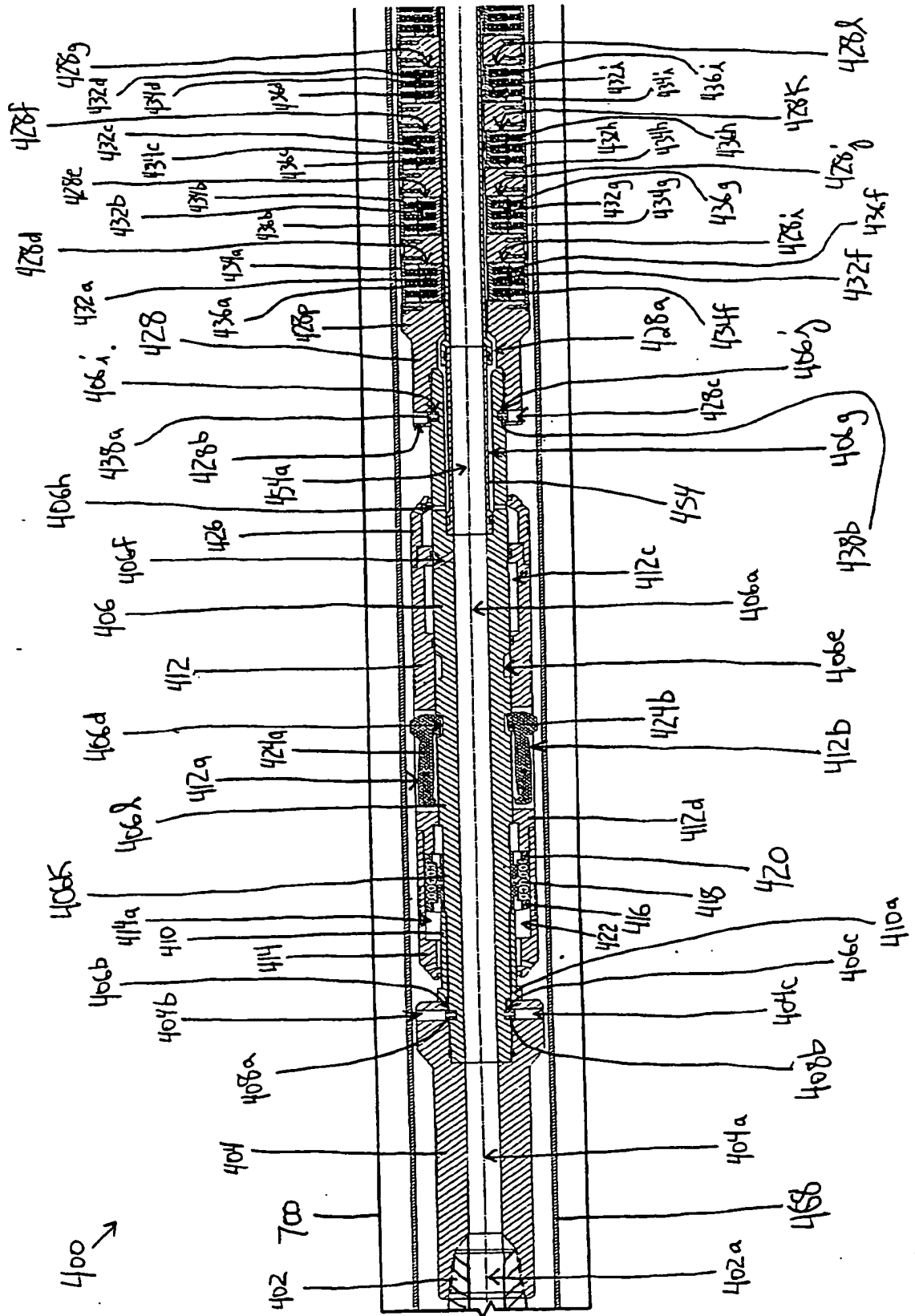

Fig. 24a

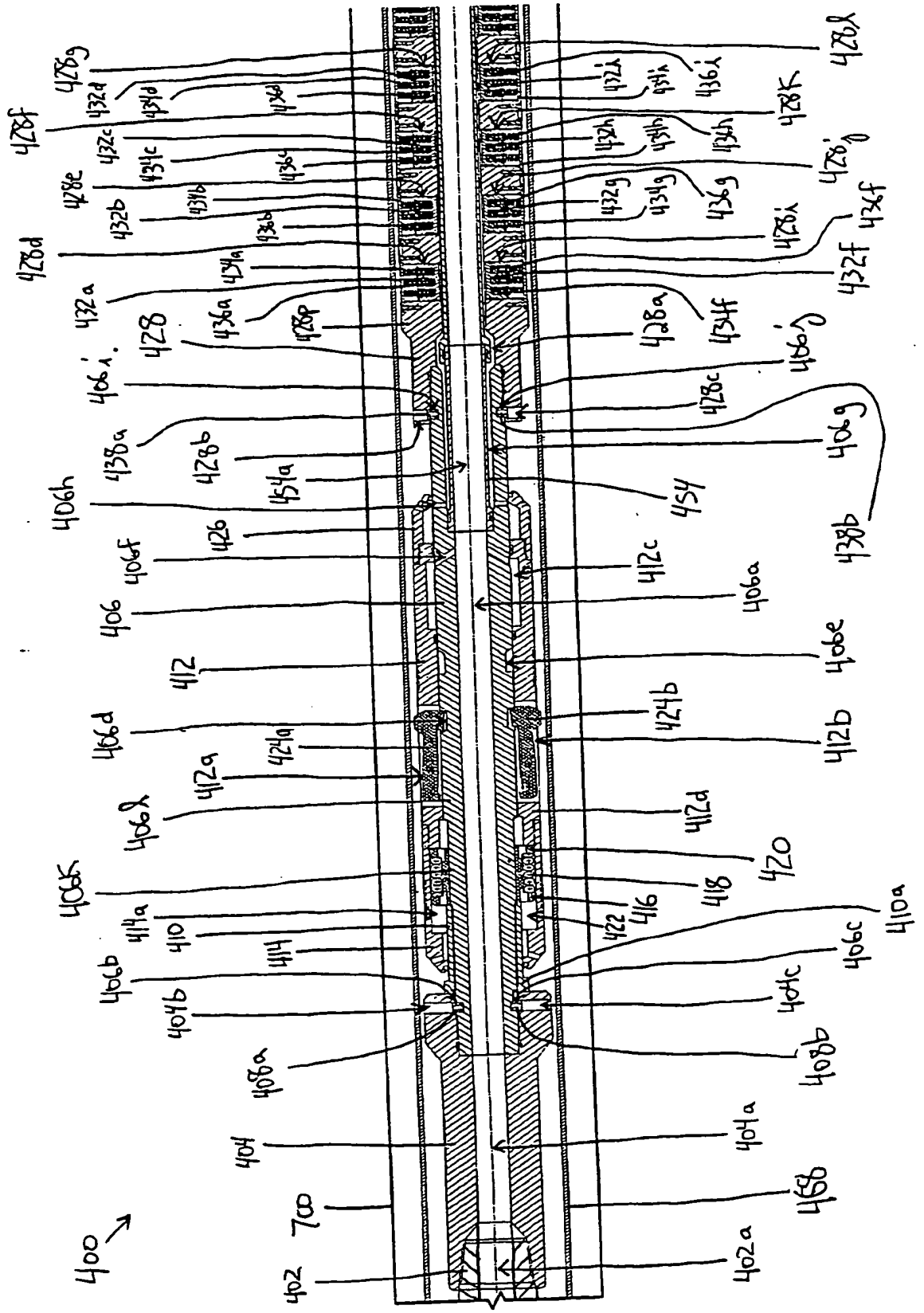

Fig. 24a





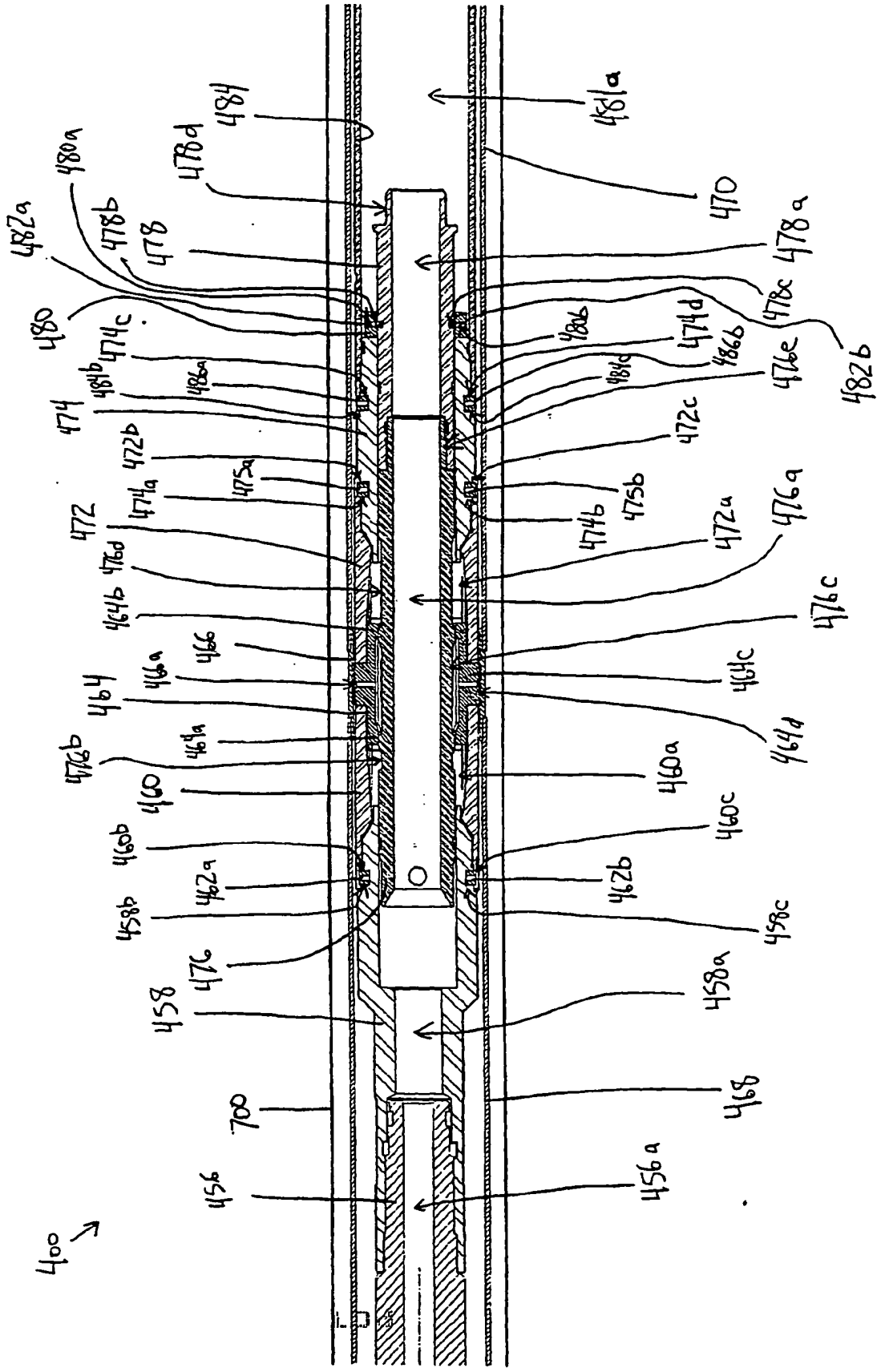

Fig. 24d

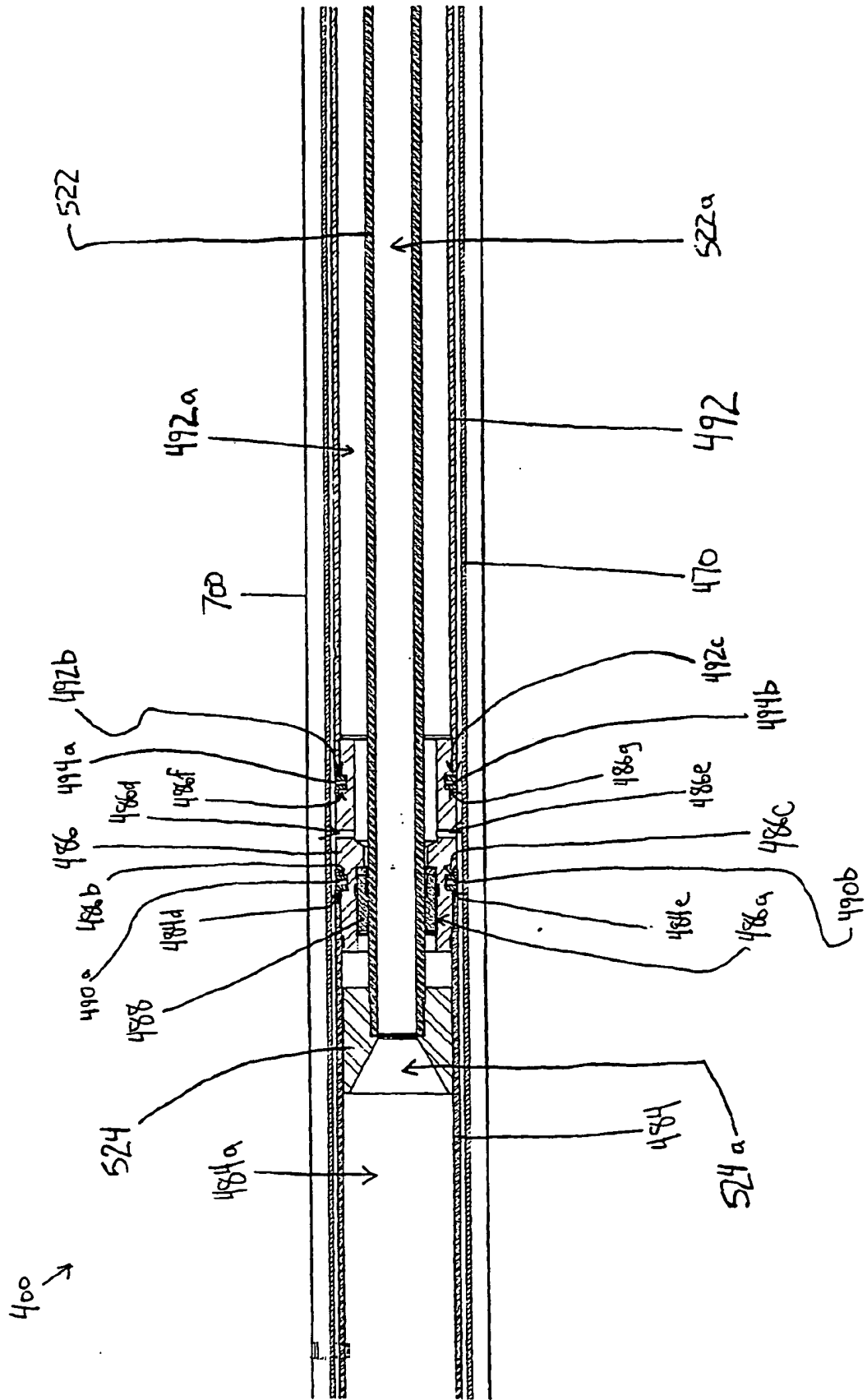
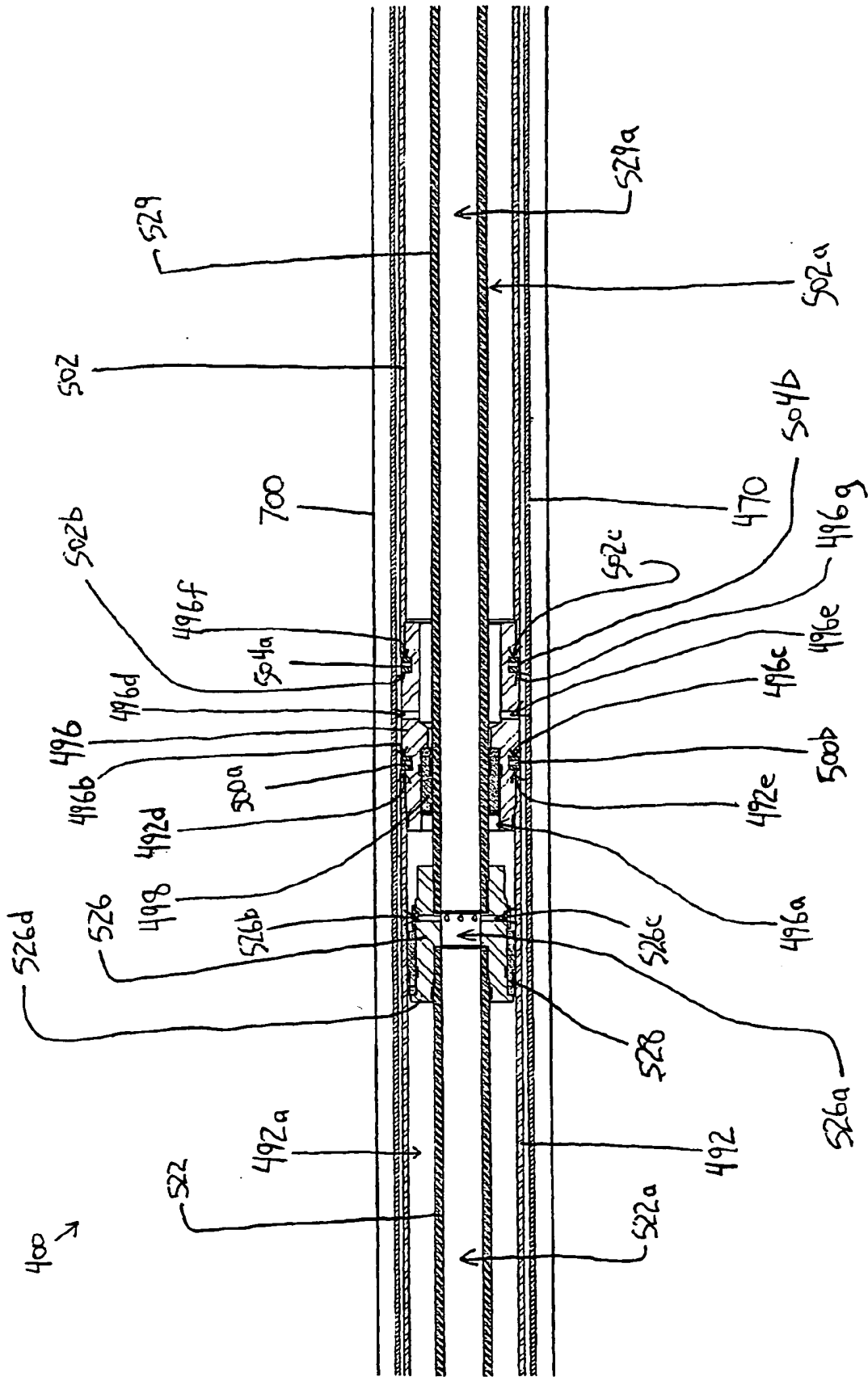

Fig. 24e



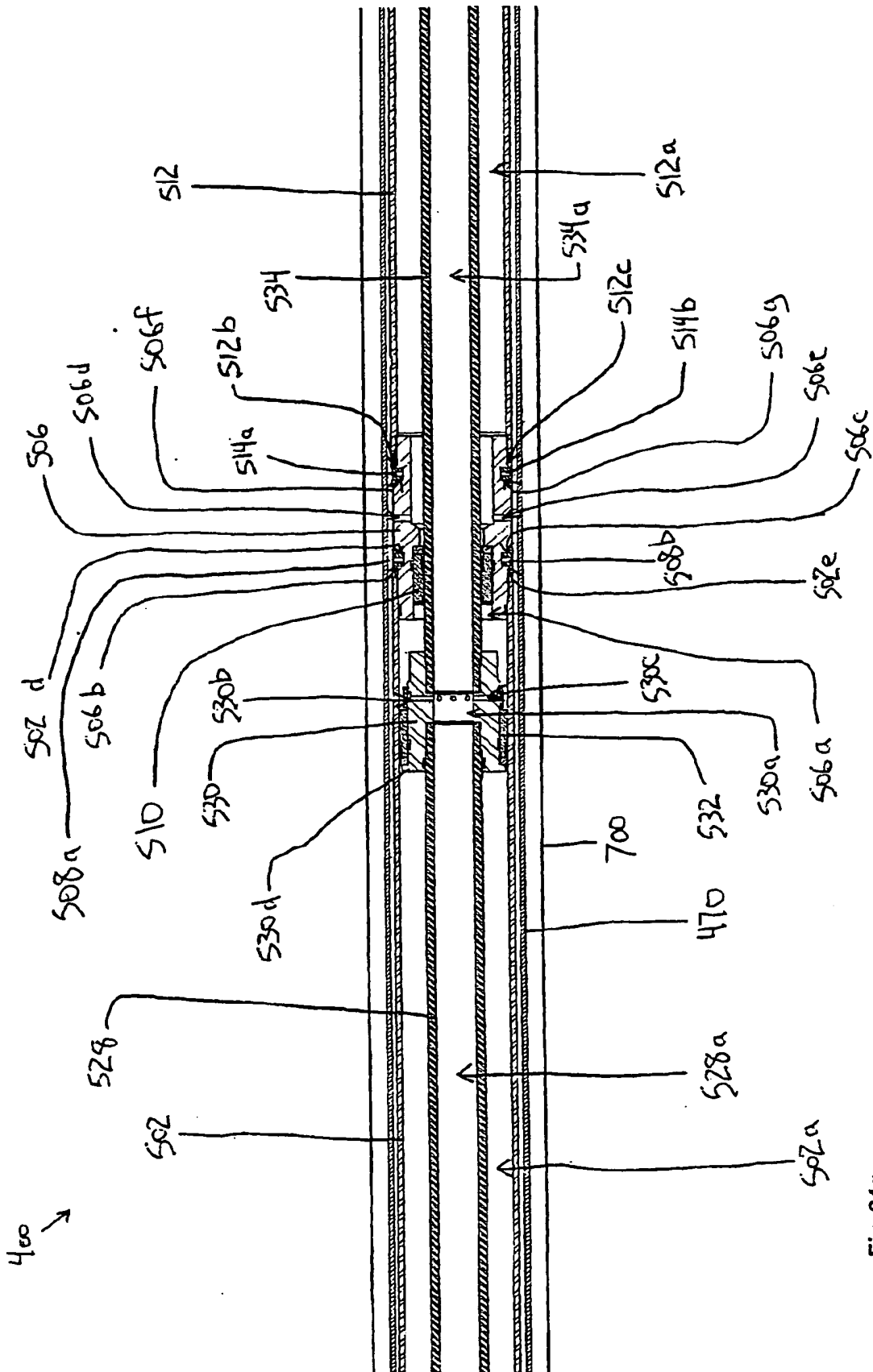

Fig. 24g





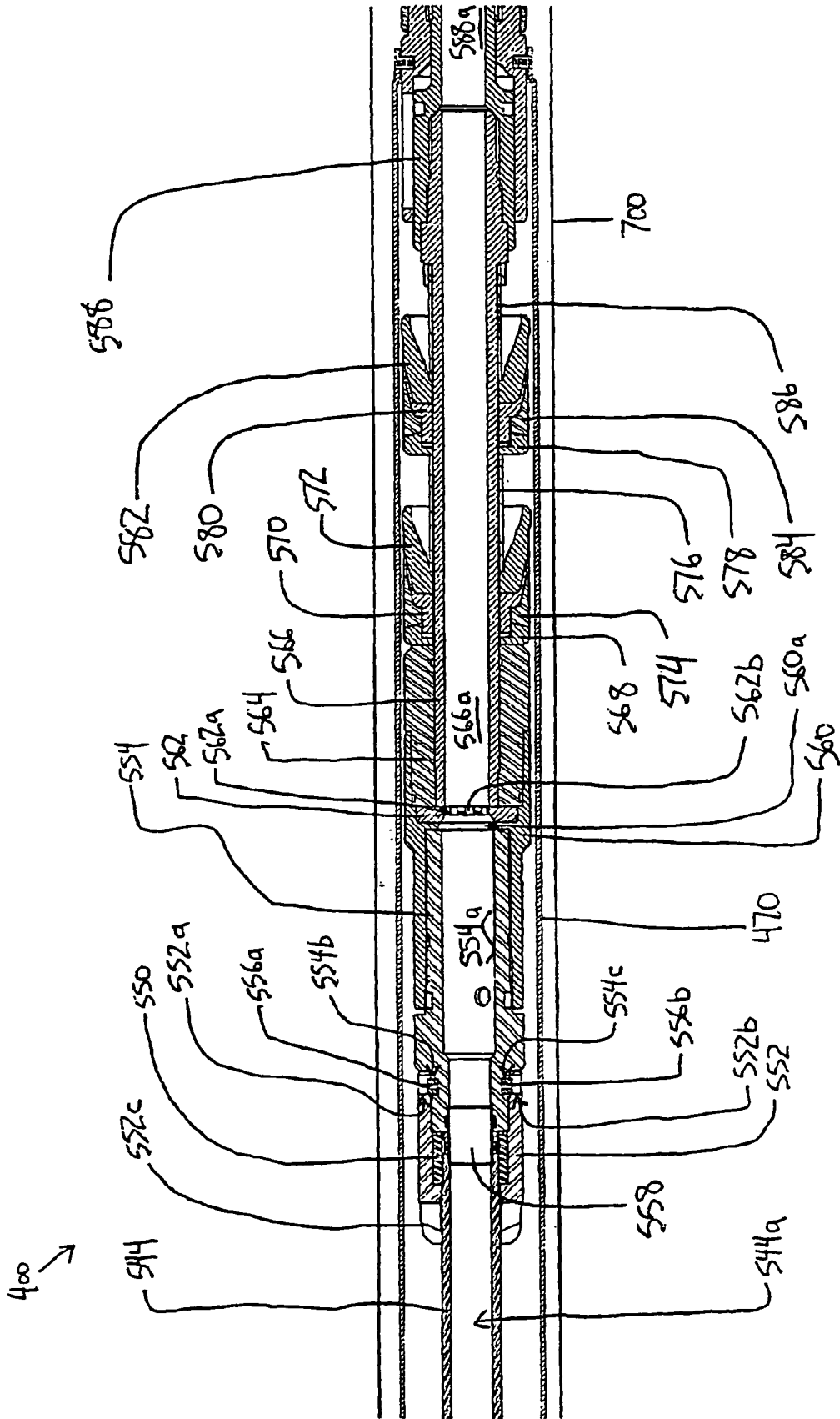

Fig. 24I

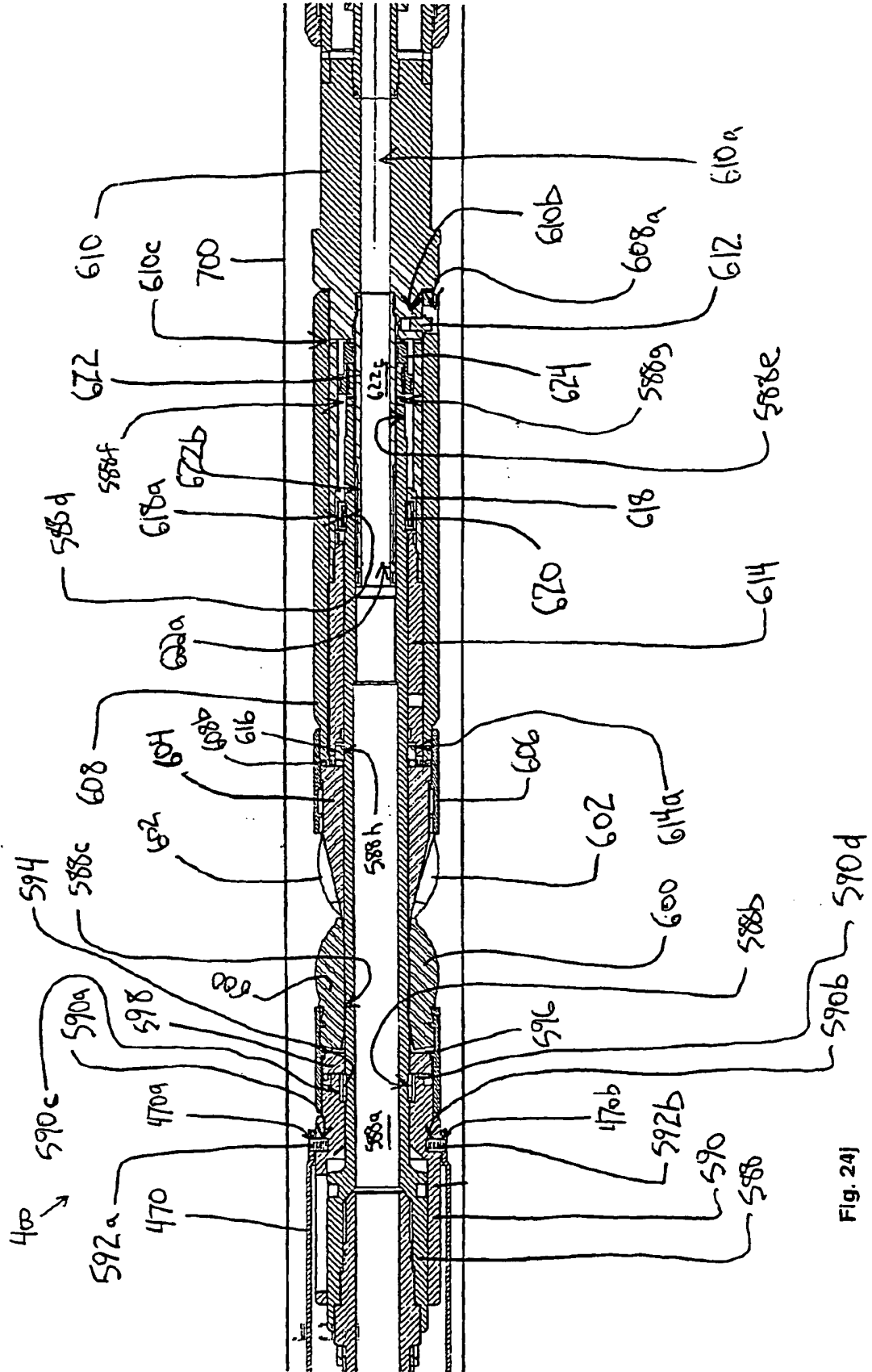

Fig. 24j

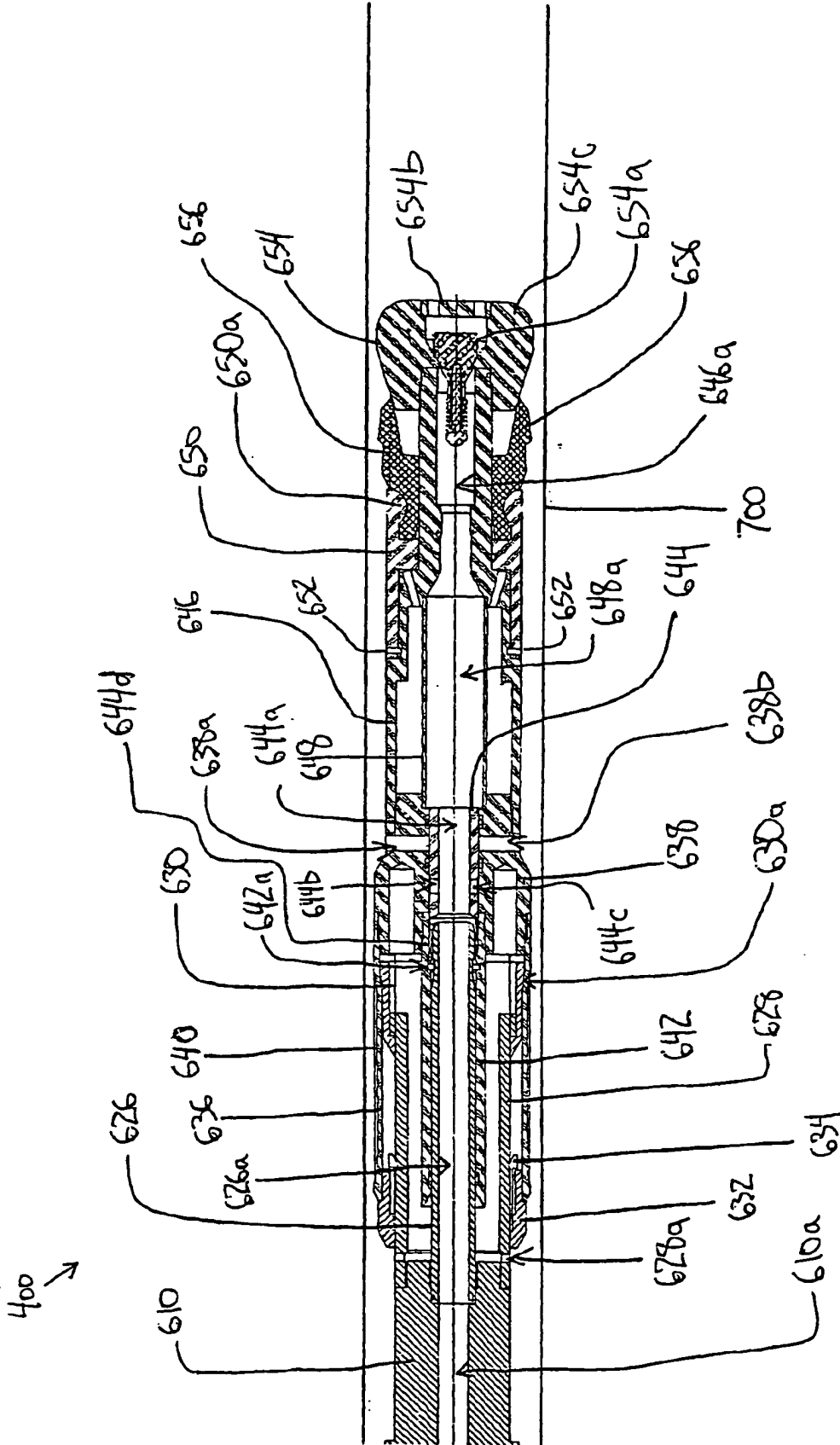

Fig. 24k

400  
↙

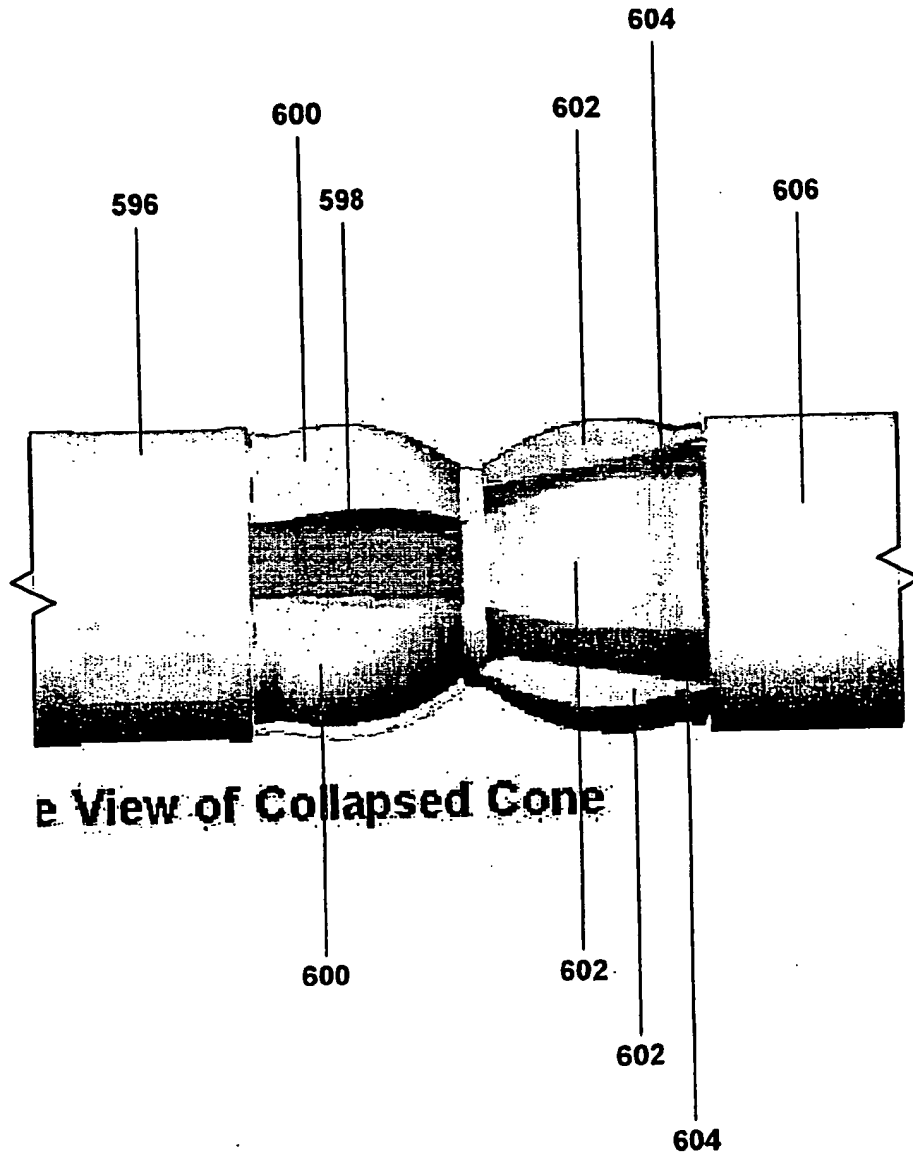

FIG. 25a

400  
↙

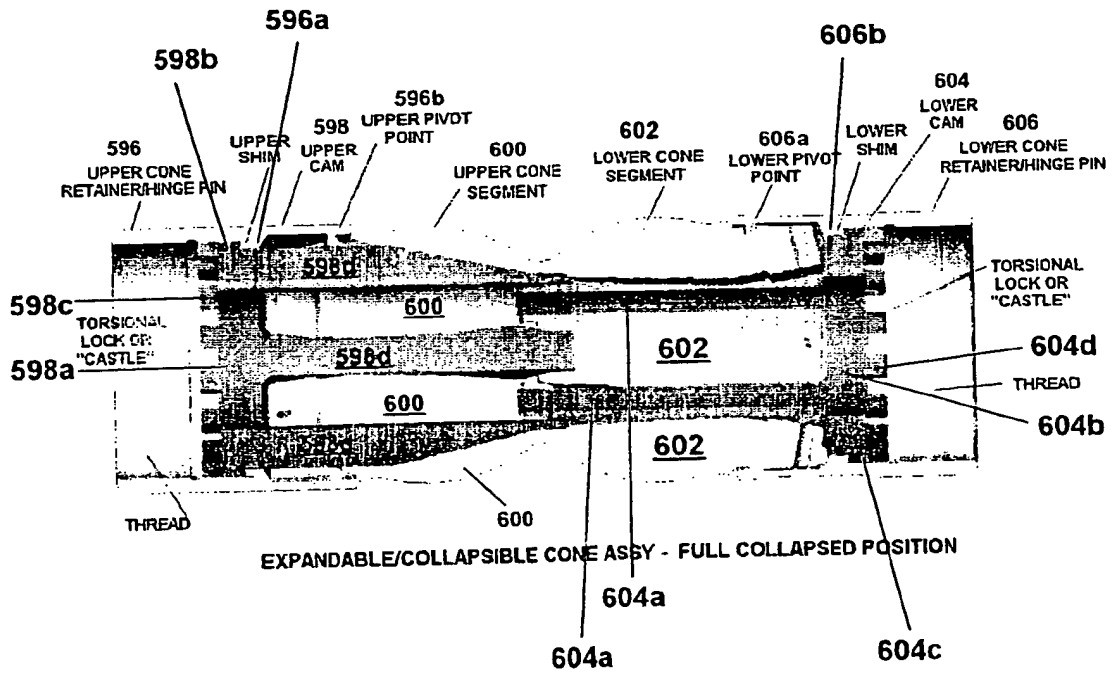

FIG. 25b



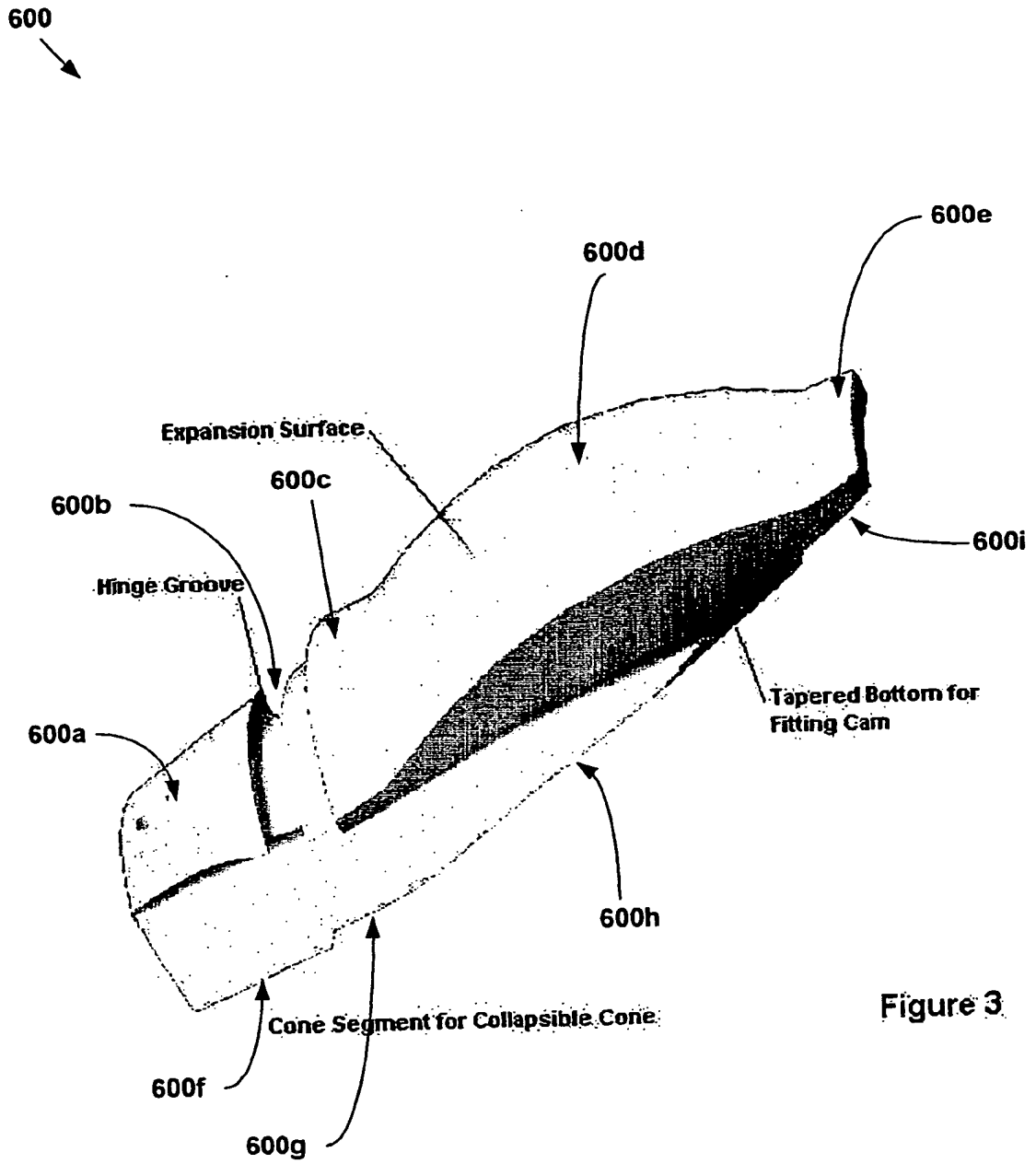

FIG. 25d



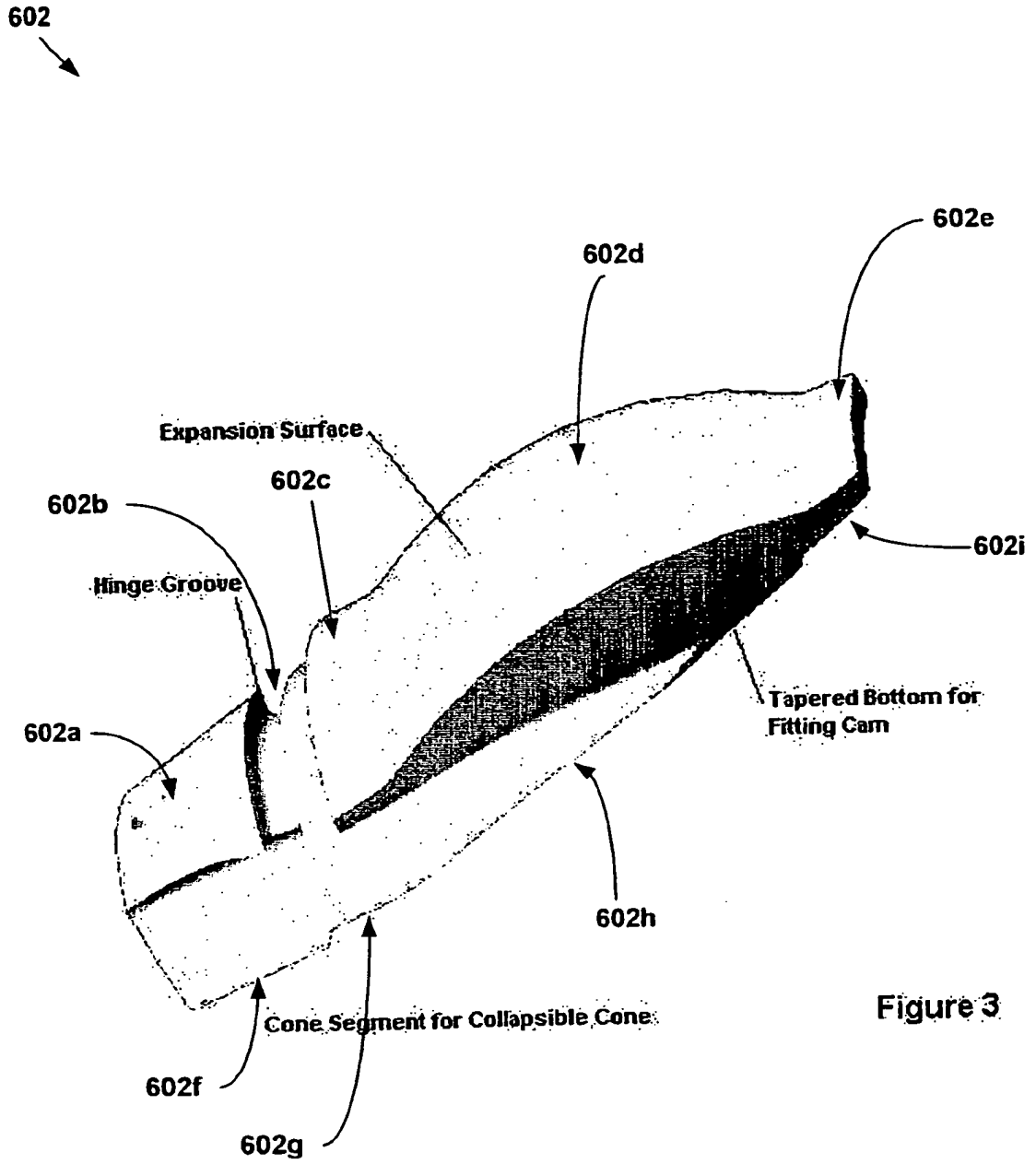

FIG. 25e

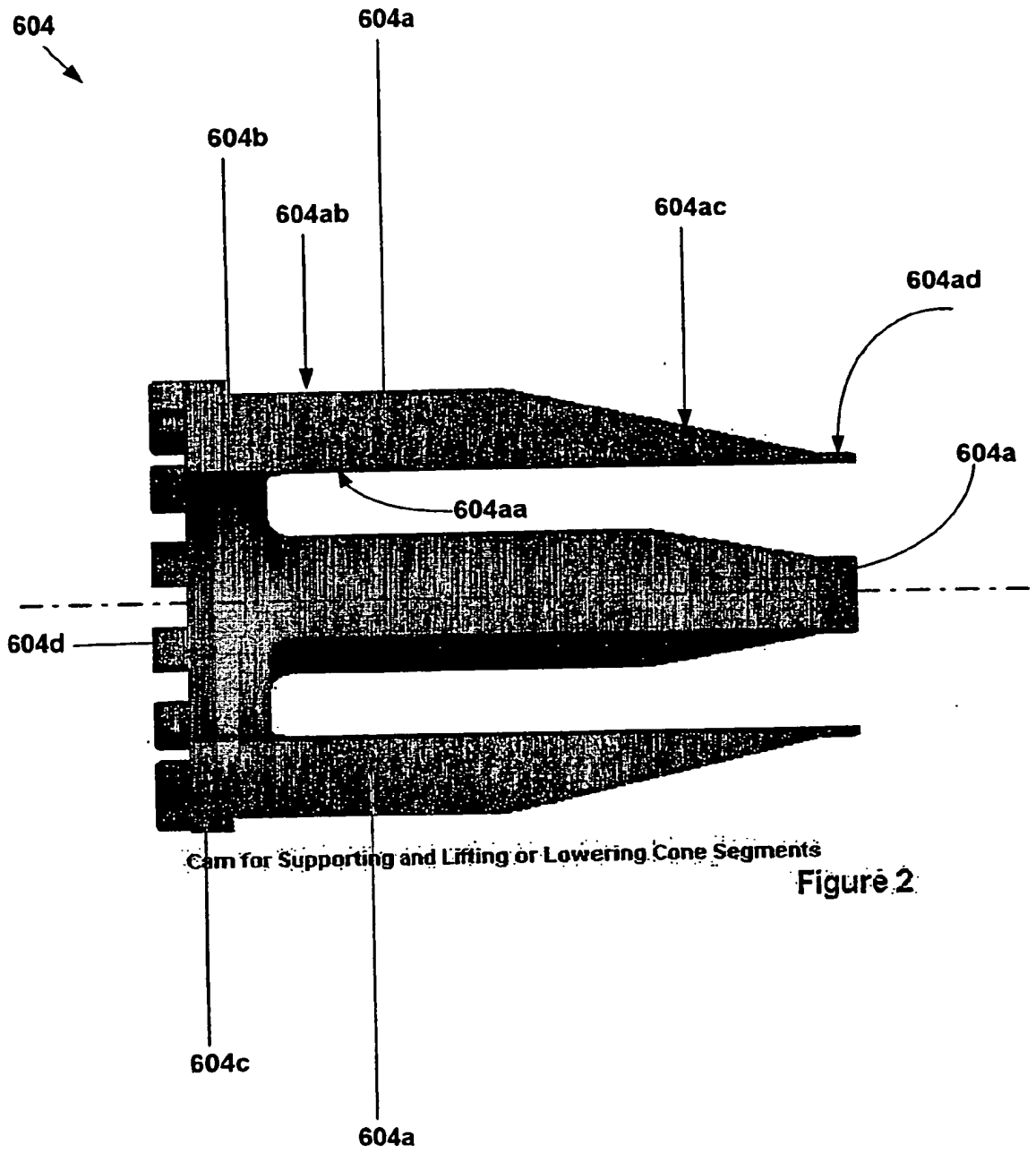
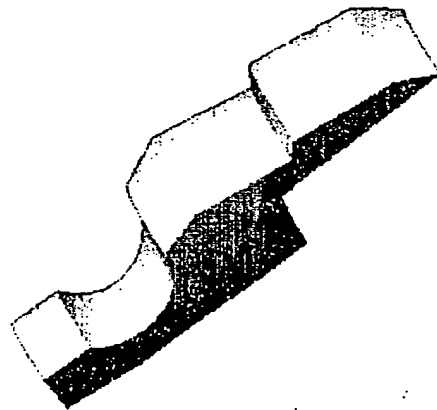

Figure 2

FIG. 25f

656  
↓



**Float Shoe Locking Dog**

**Fig. 25g**

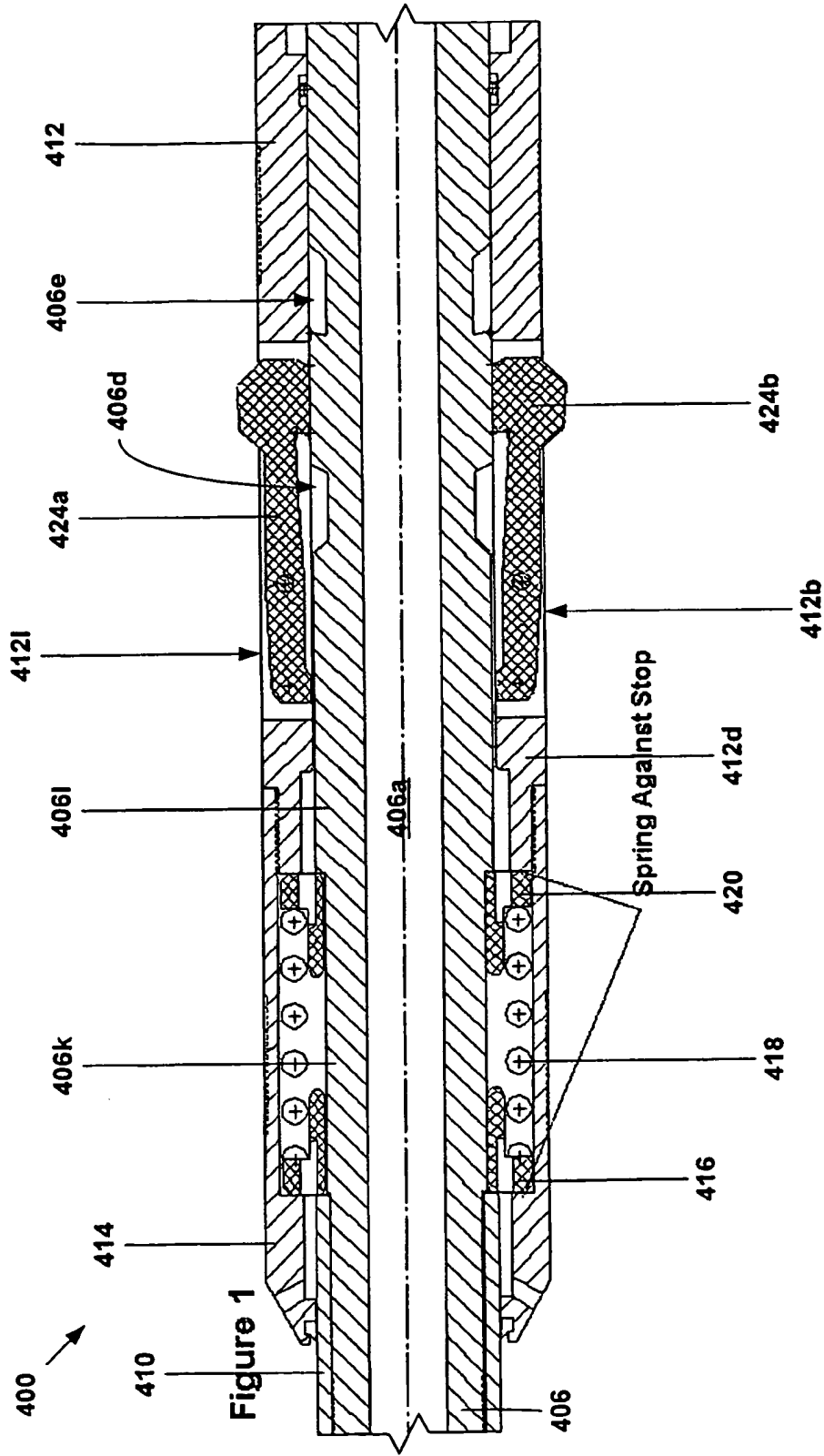

Fig. 25h

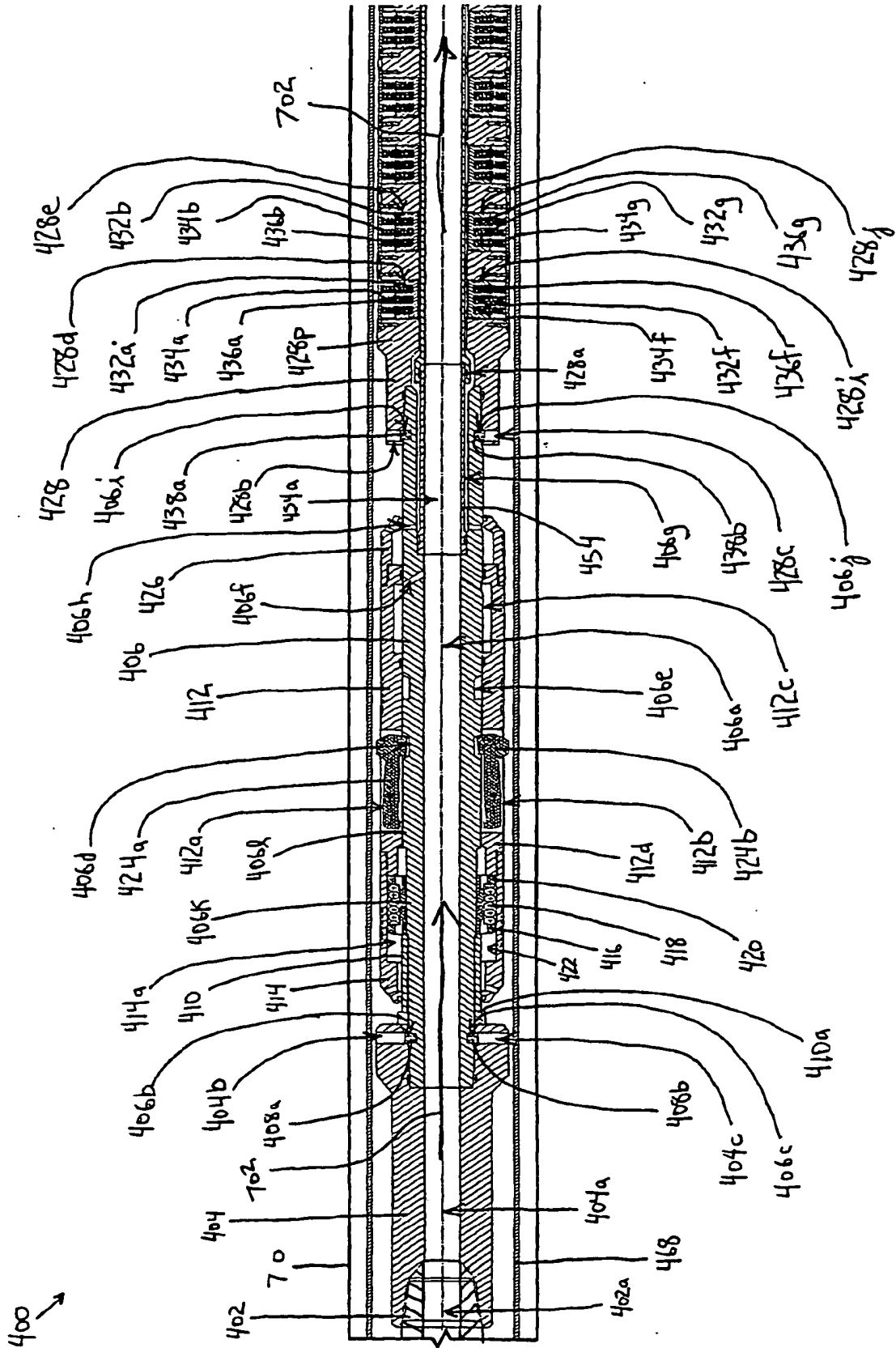

Fig. 26a



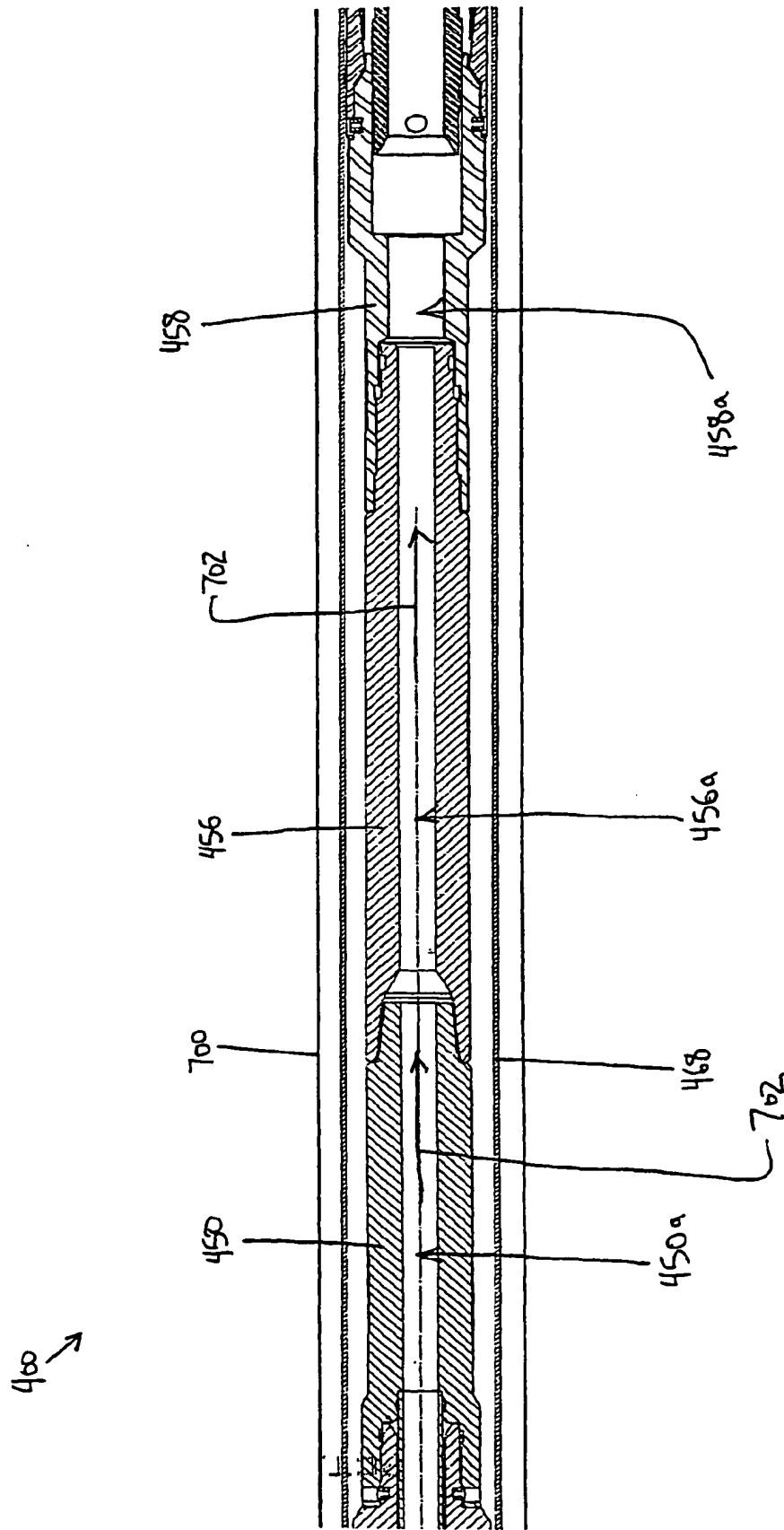

Fig. 26c

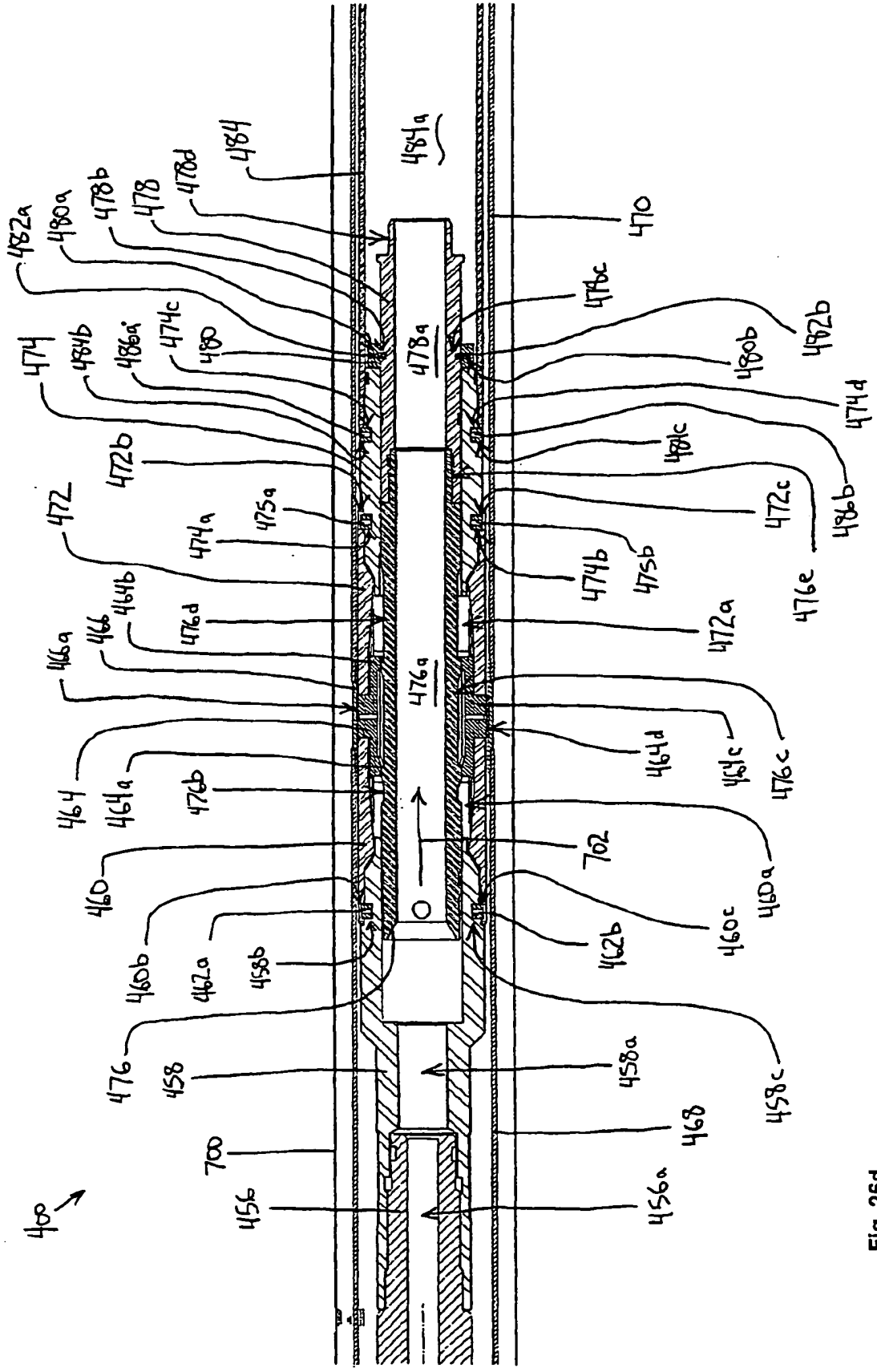

Fig. 26d





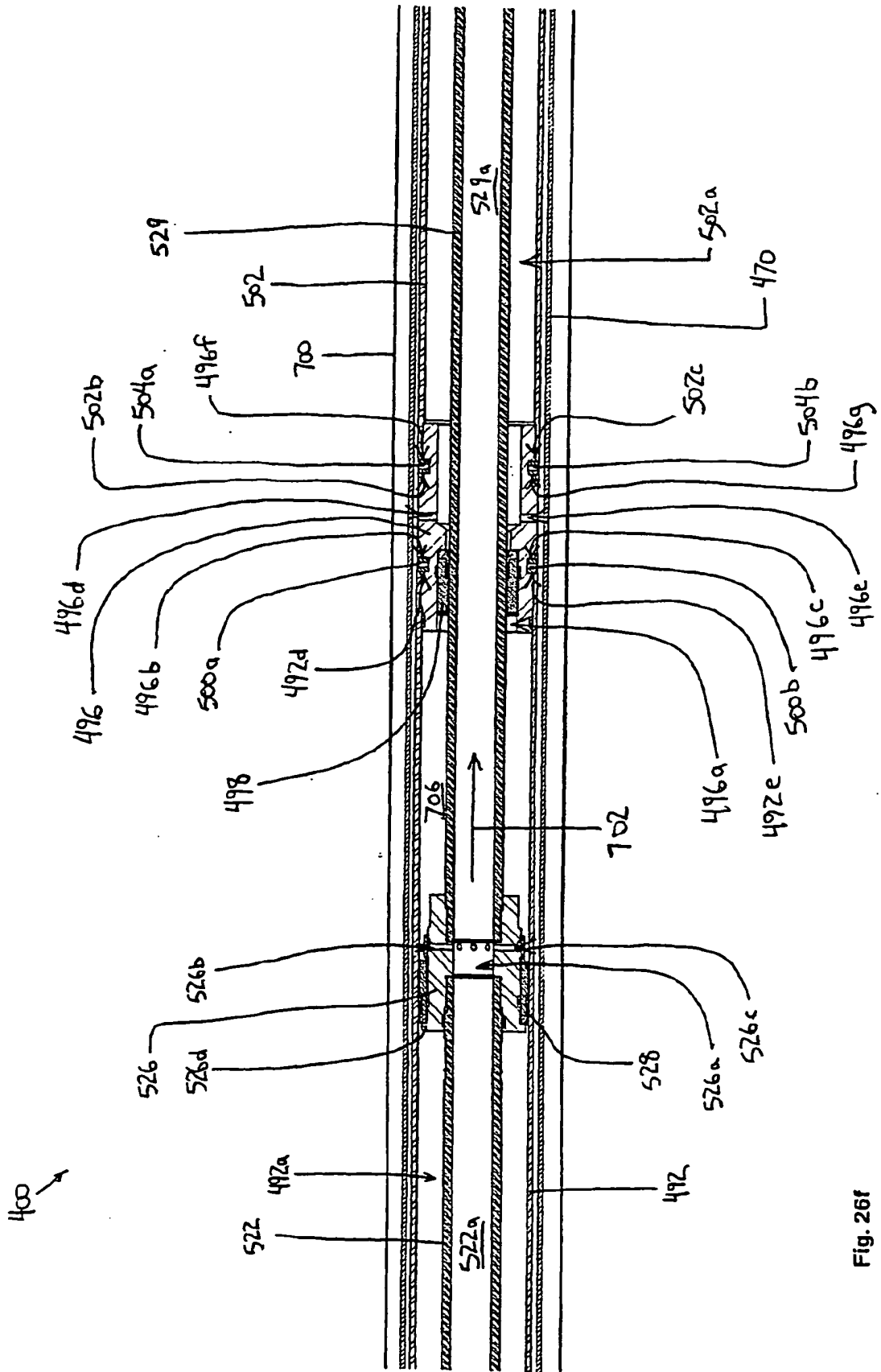

Fig. 26f

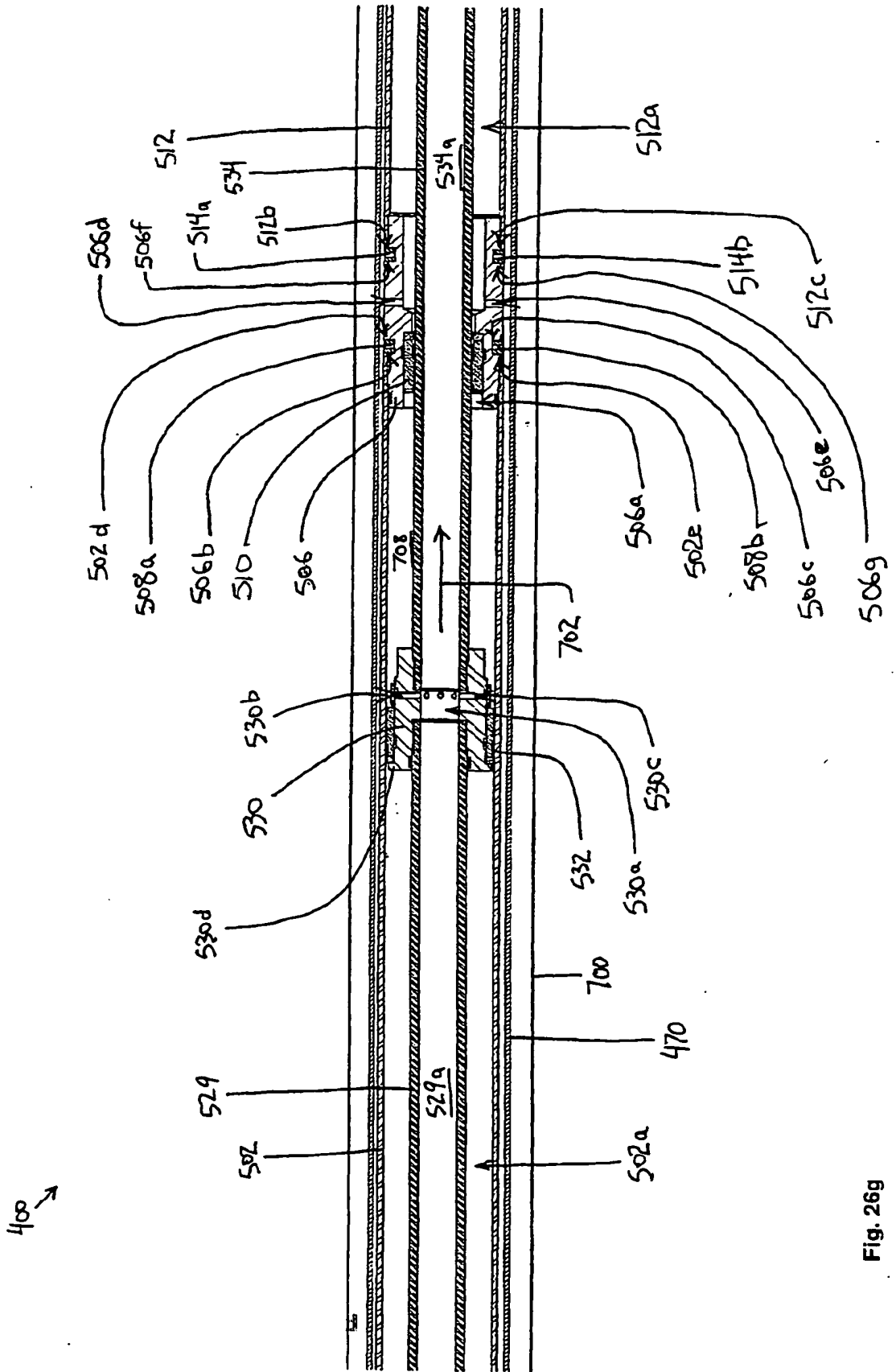

Fig. 26g

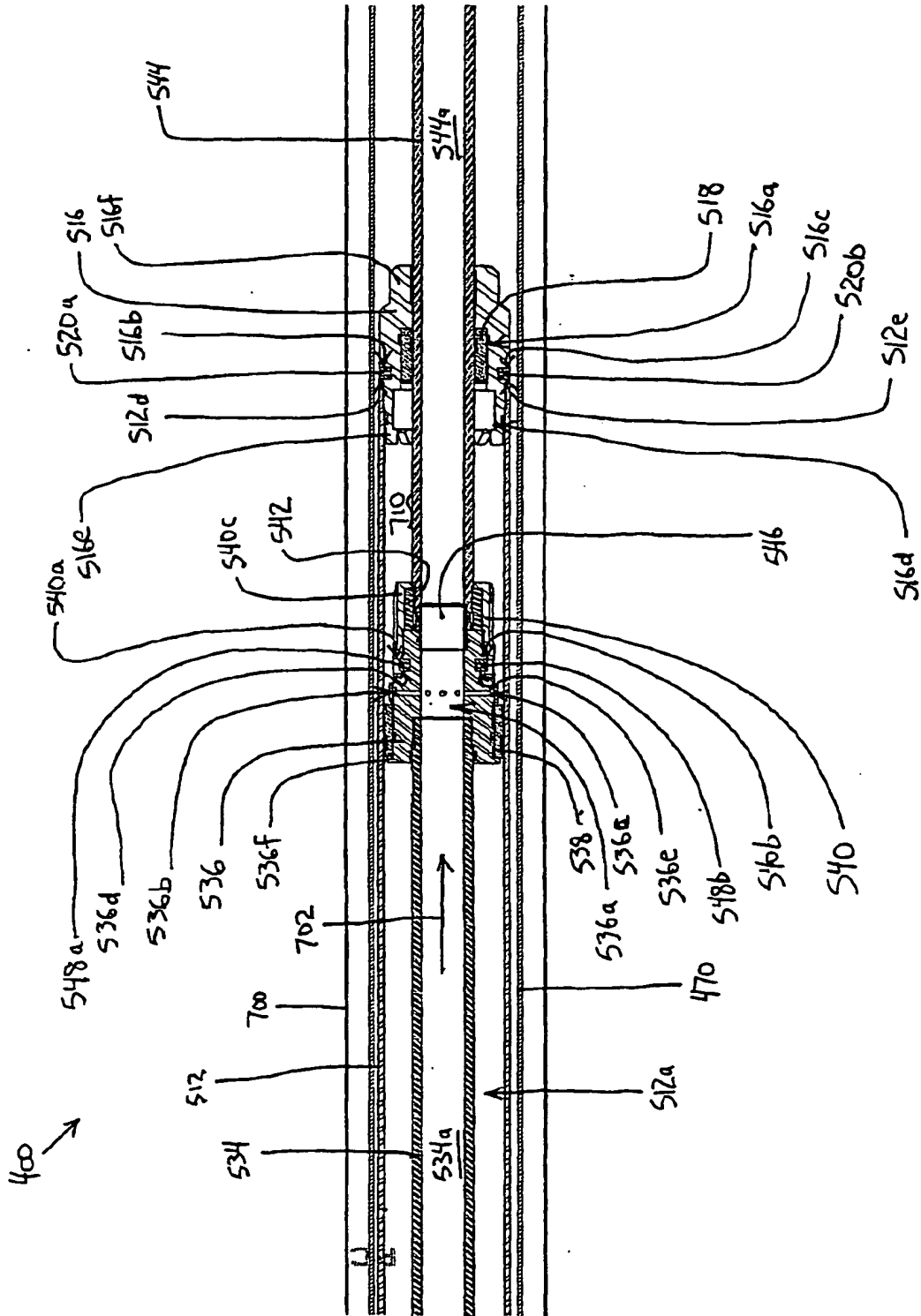

Fig. 26h

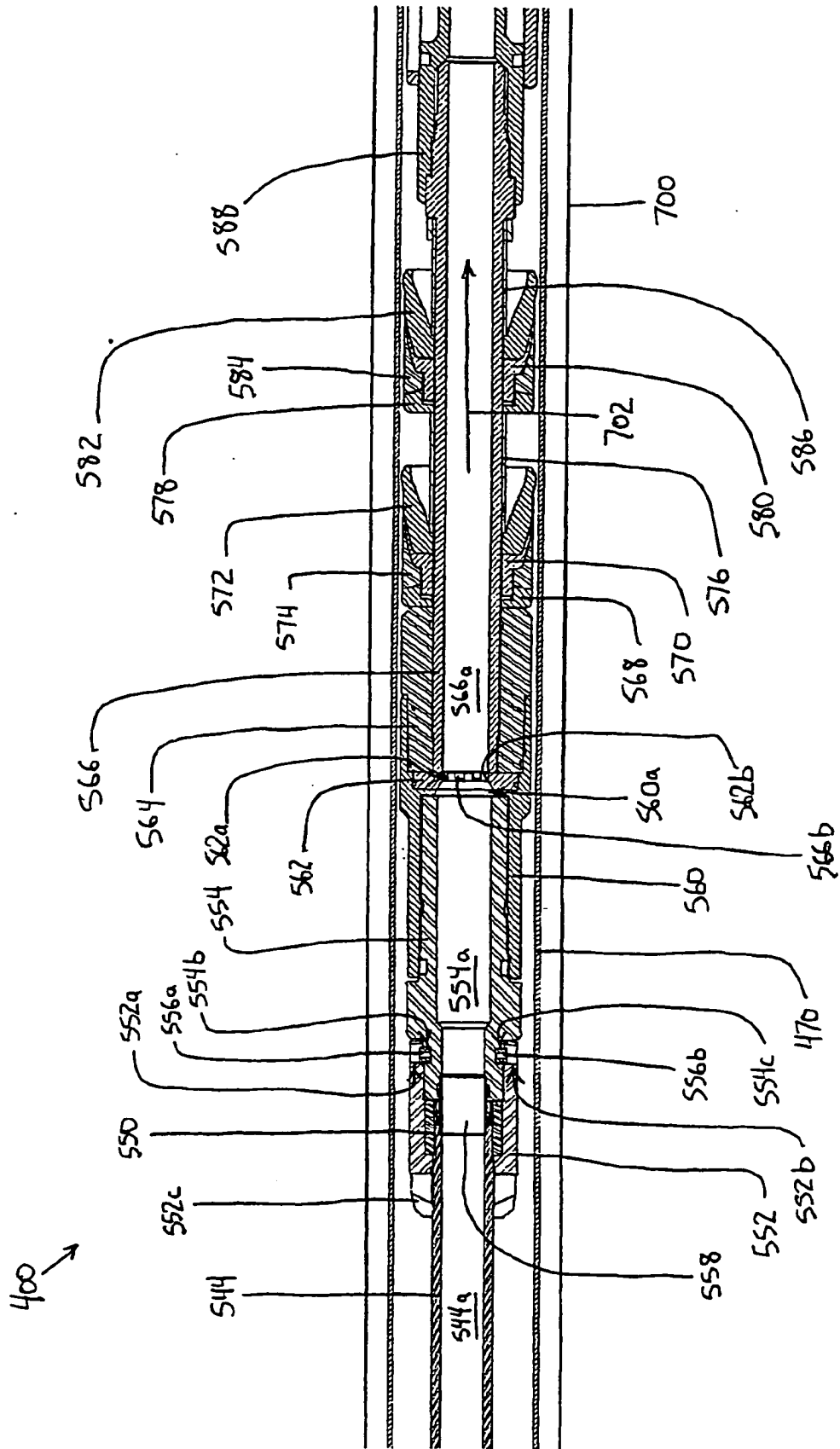

Fig. 26i





400  
↙

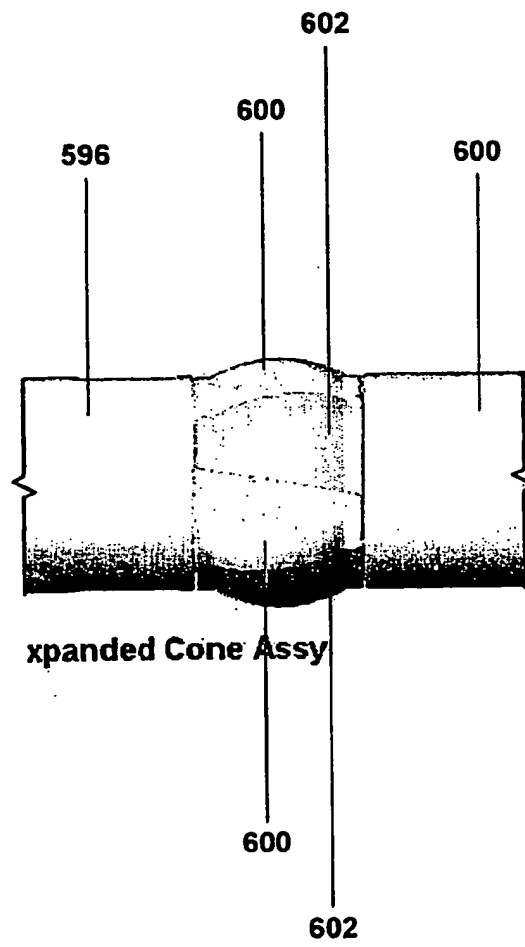

FIG. 27a



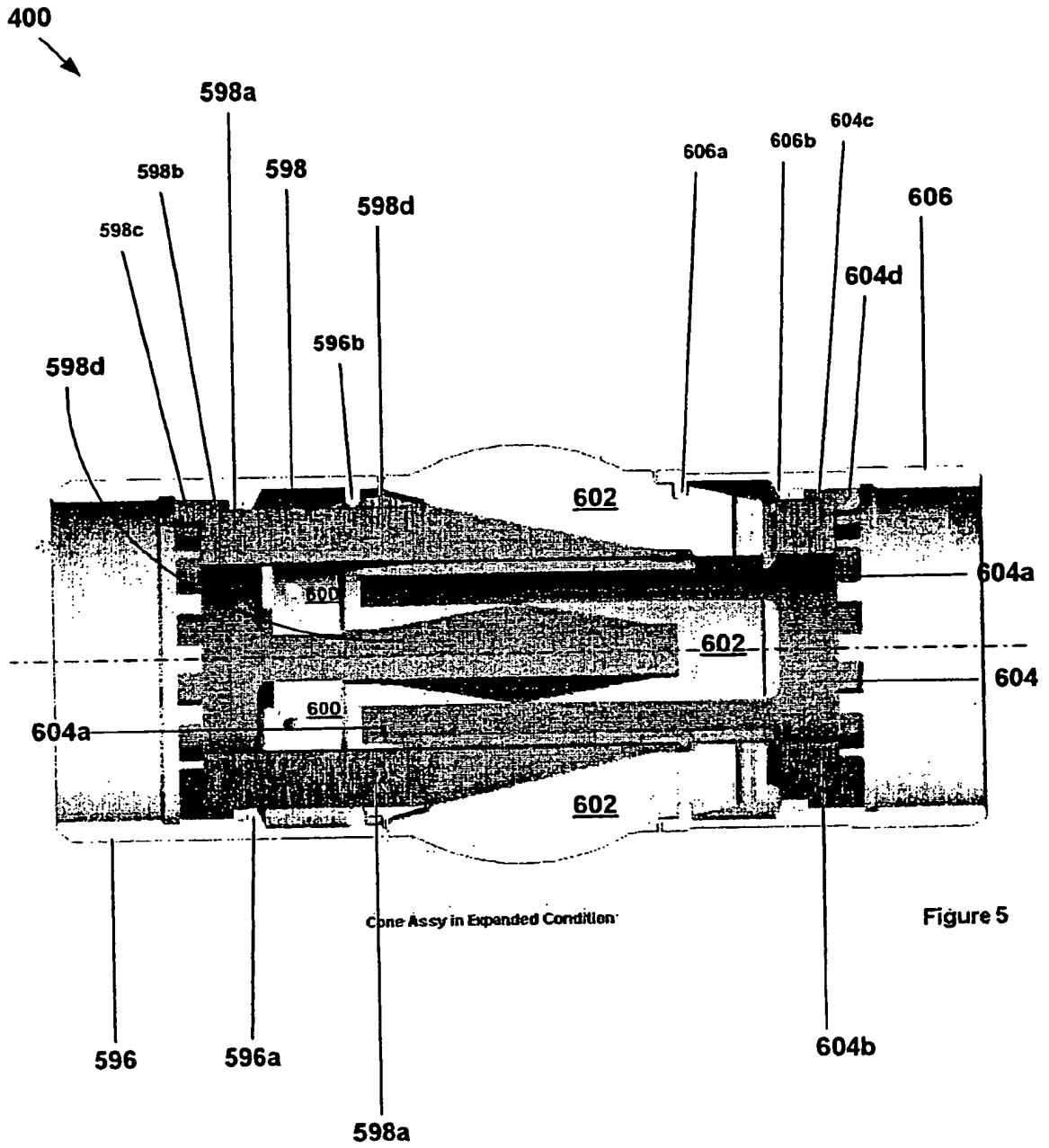

FIG. 27b

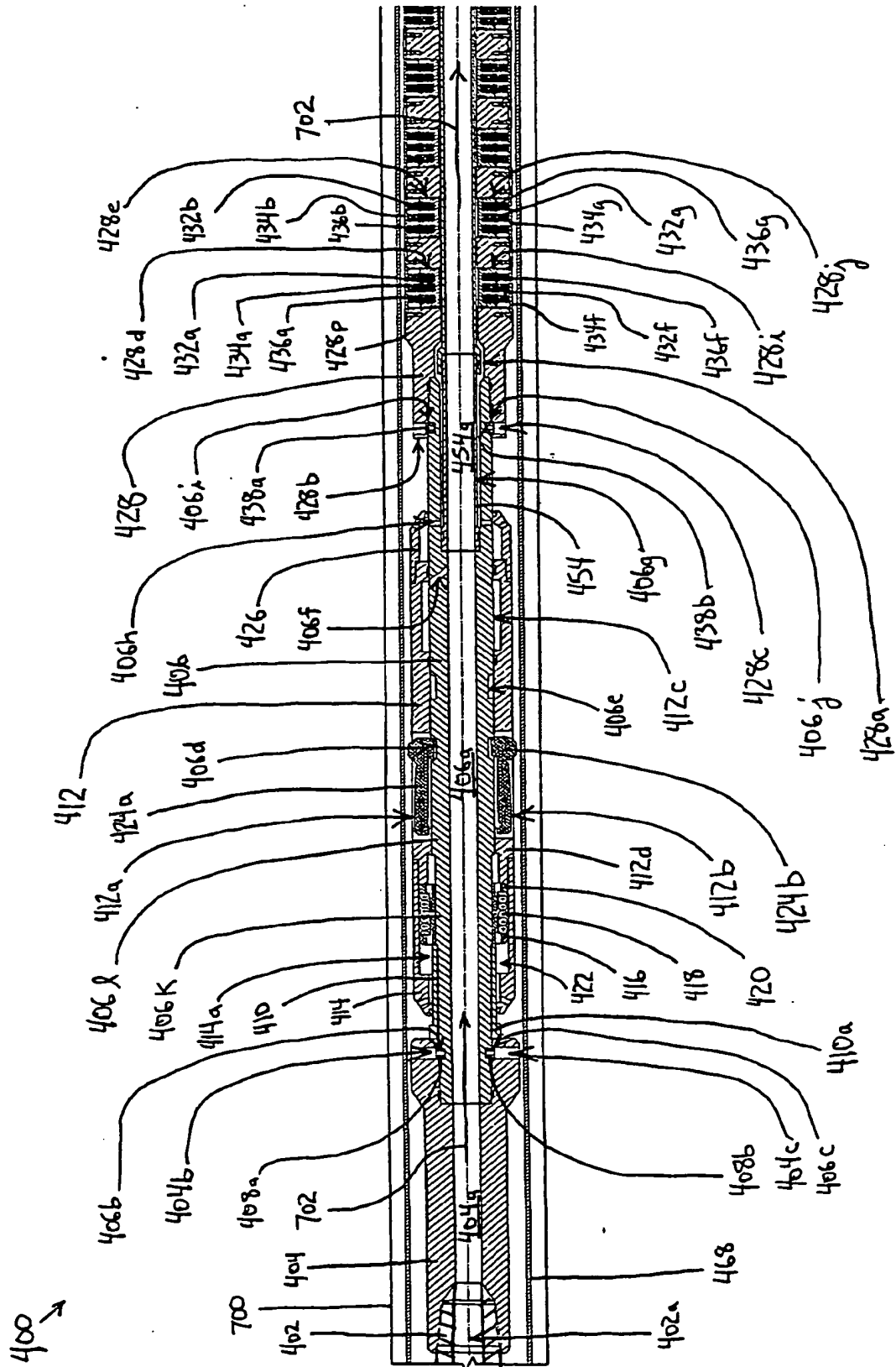

Fig. 28a

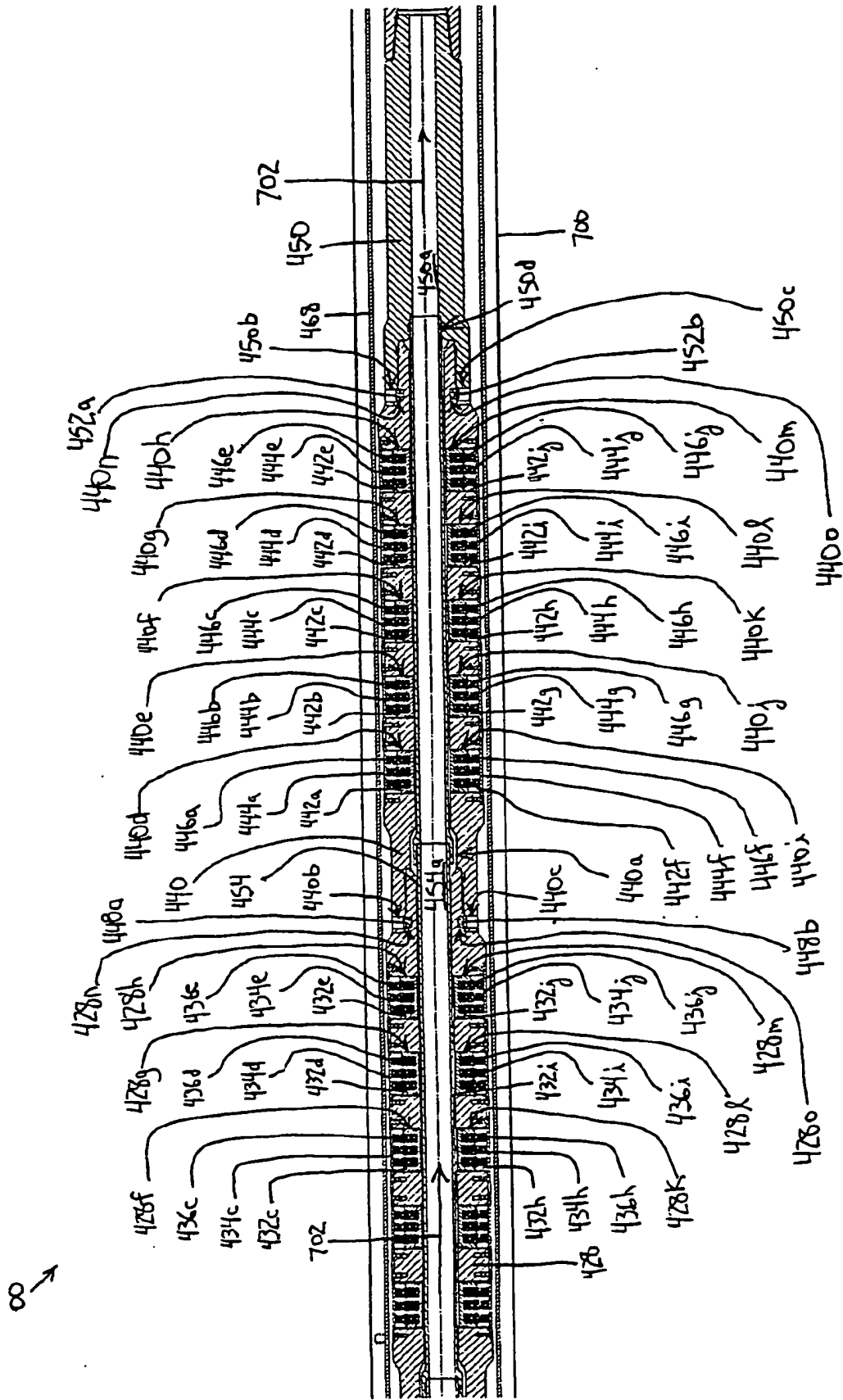

Fig. 28b

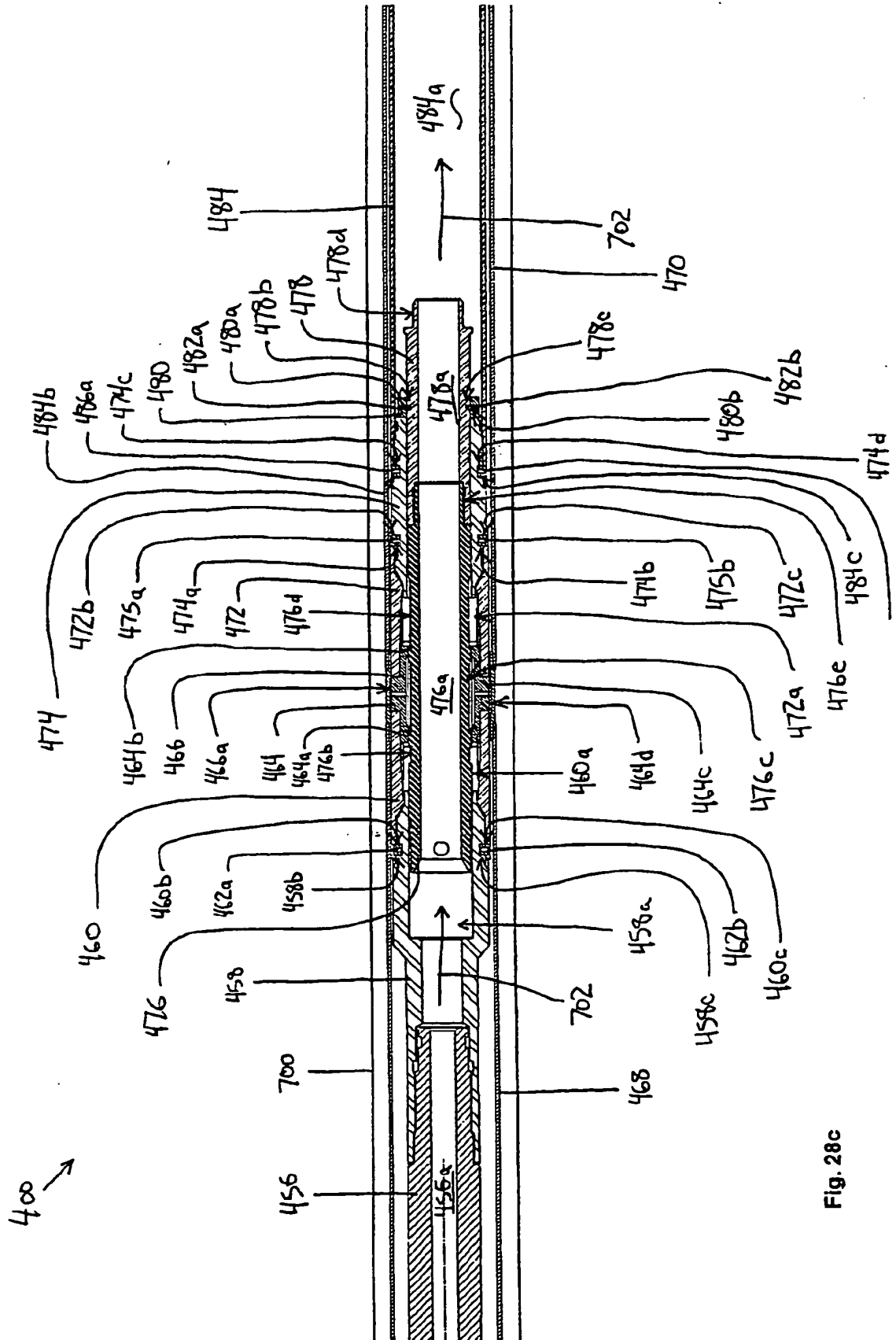

Fig. 28c





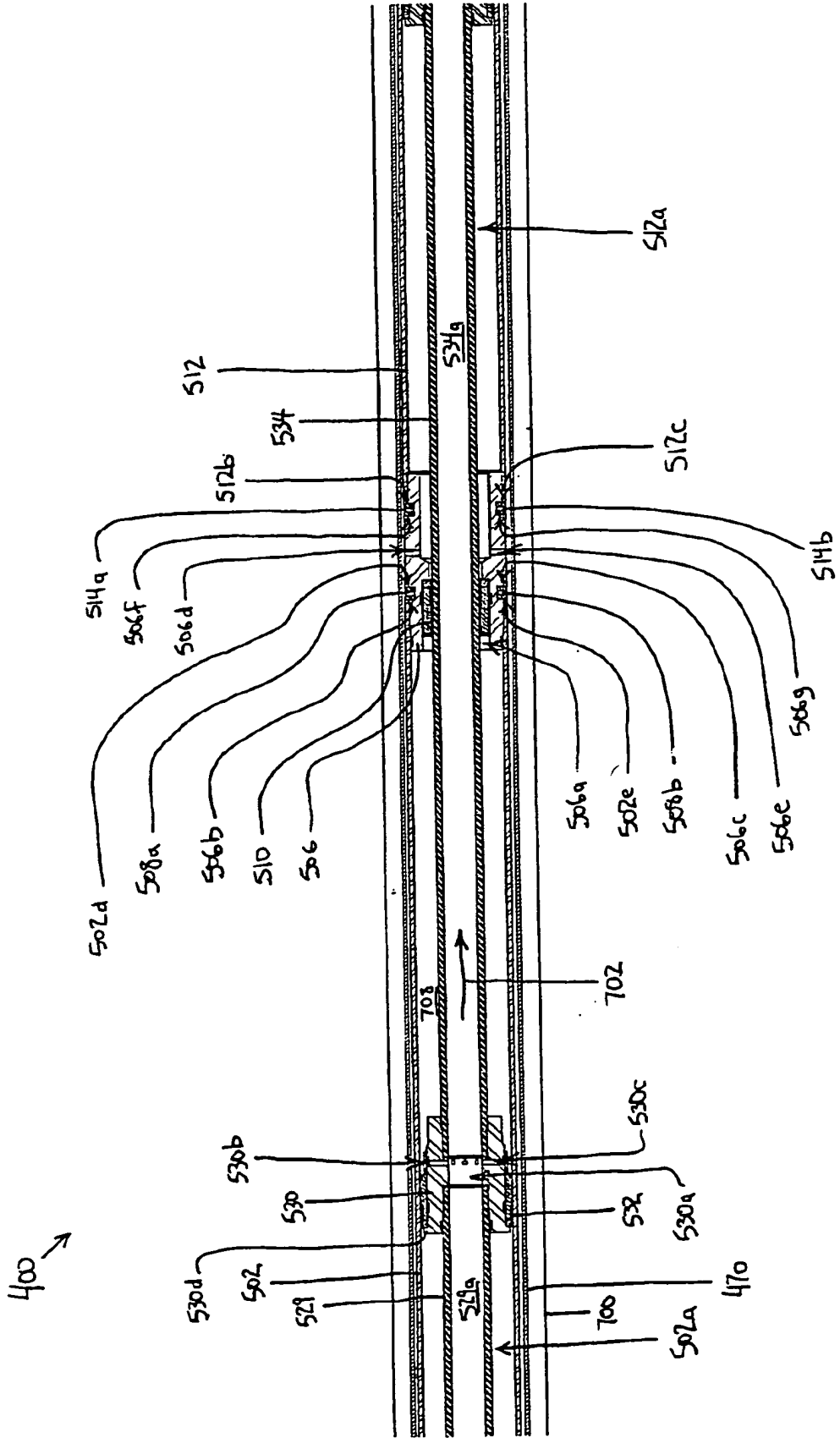

Fig. 28f





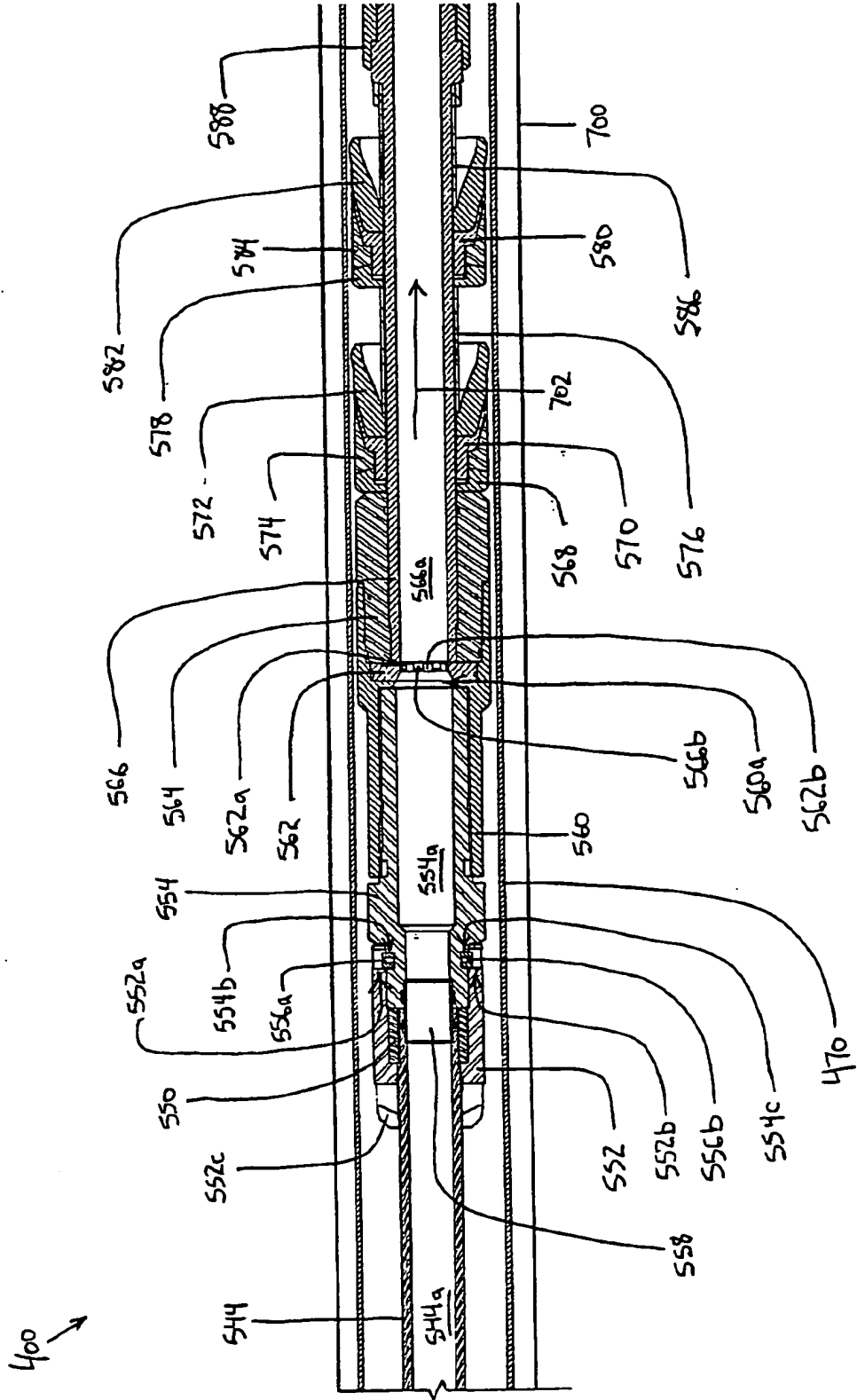

Fig. 28h

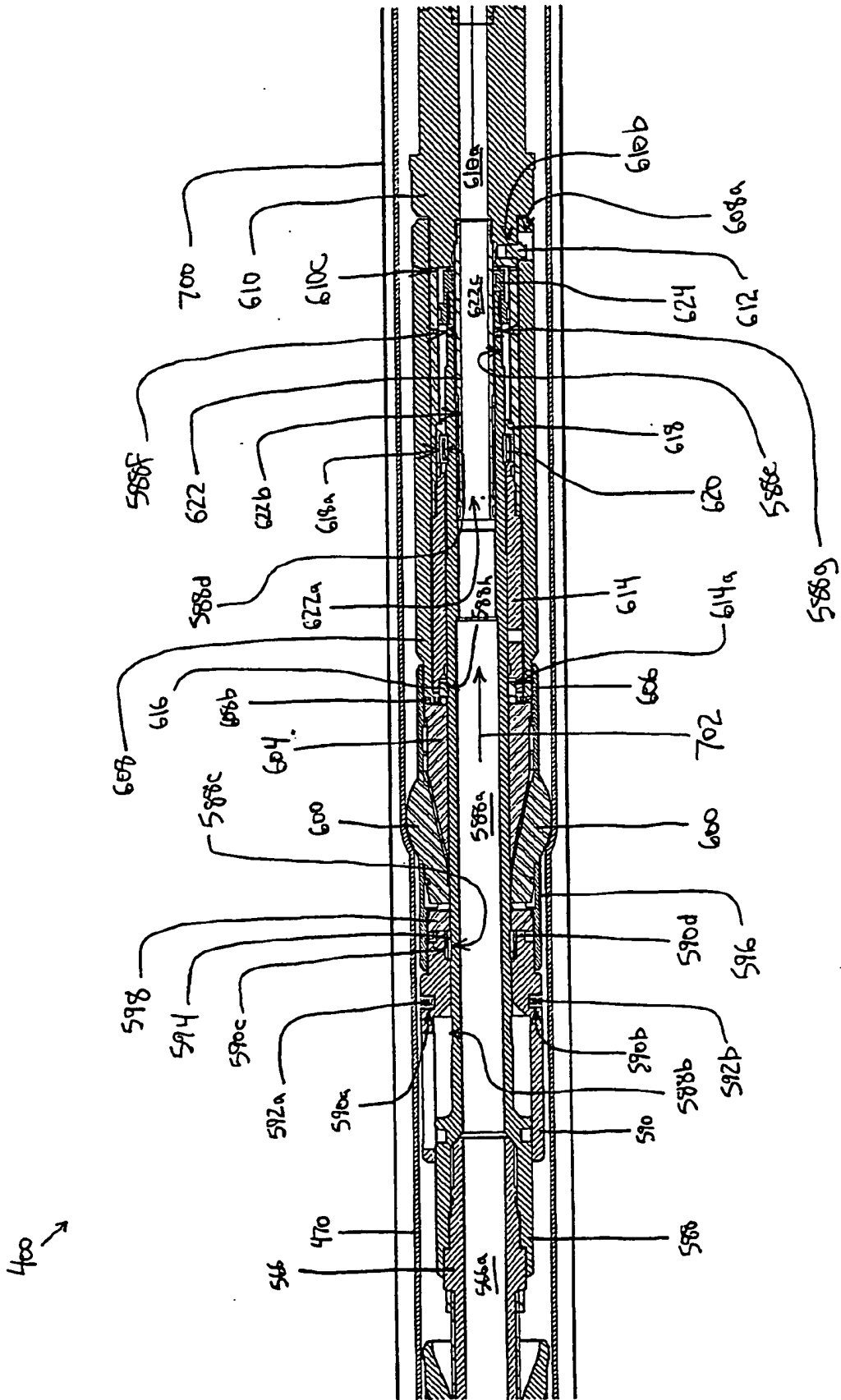
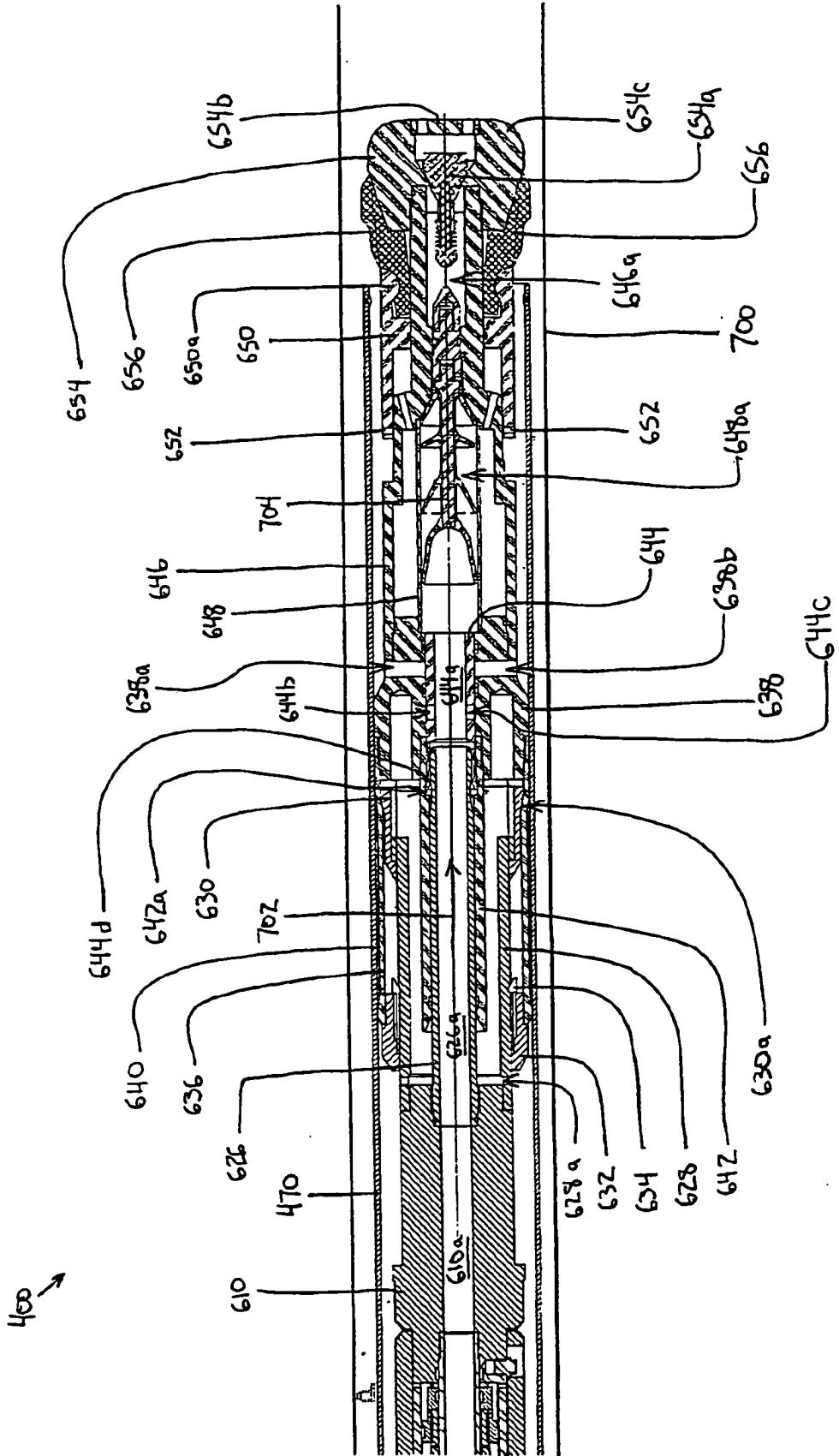

Fig. 281



400 →

Fig. 28J





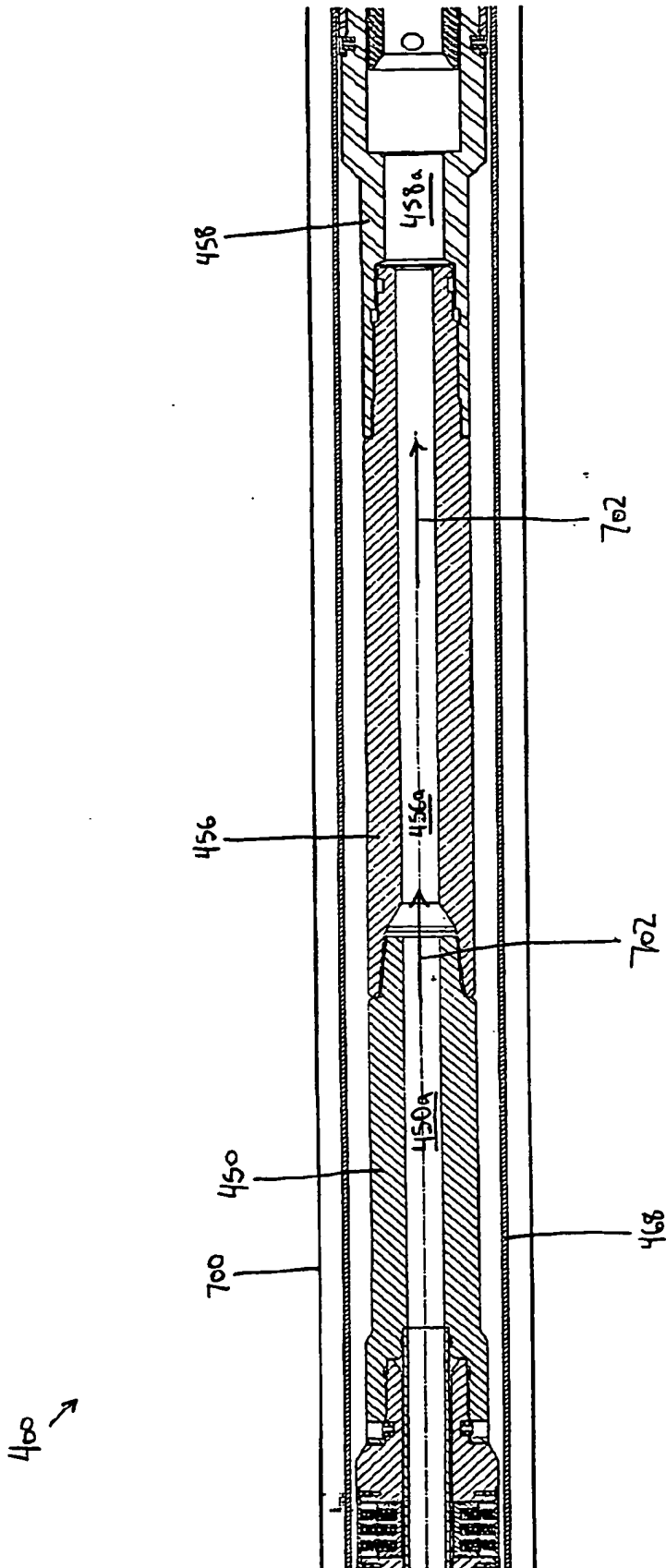

Fig. 29c

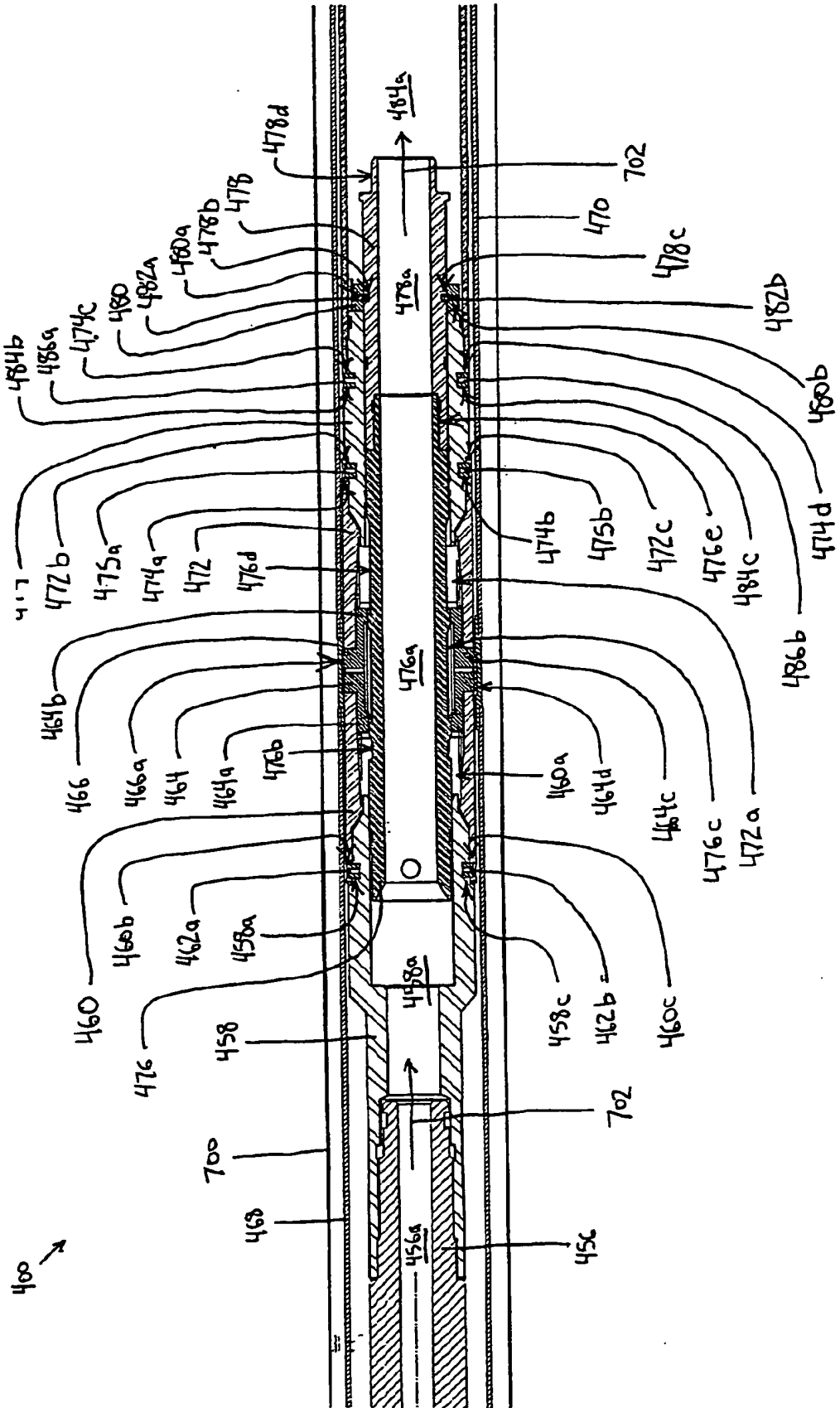

Fig. 29d

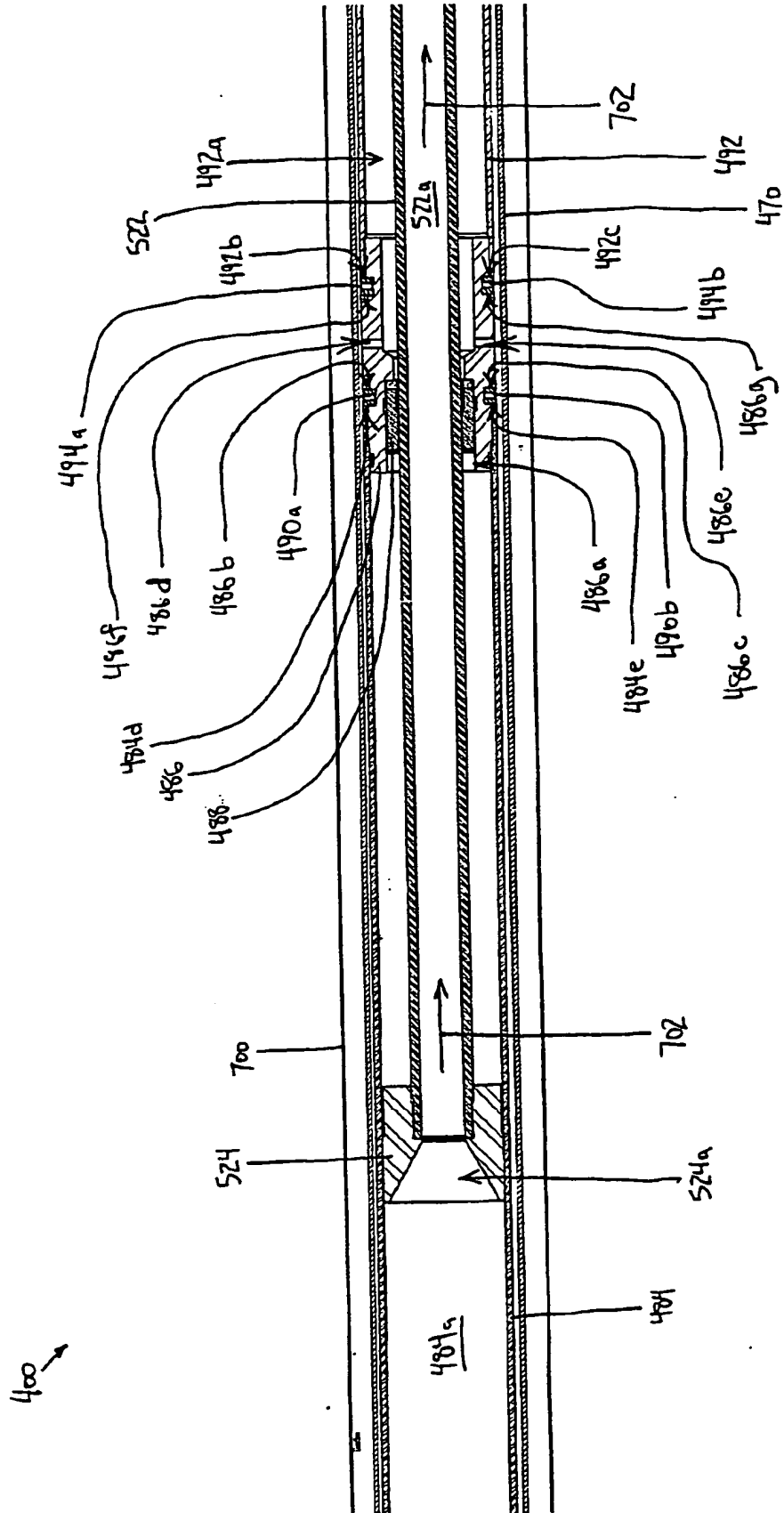

Fig. 29e



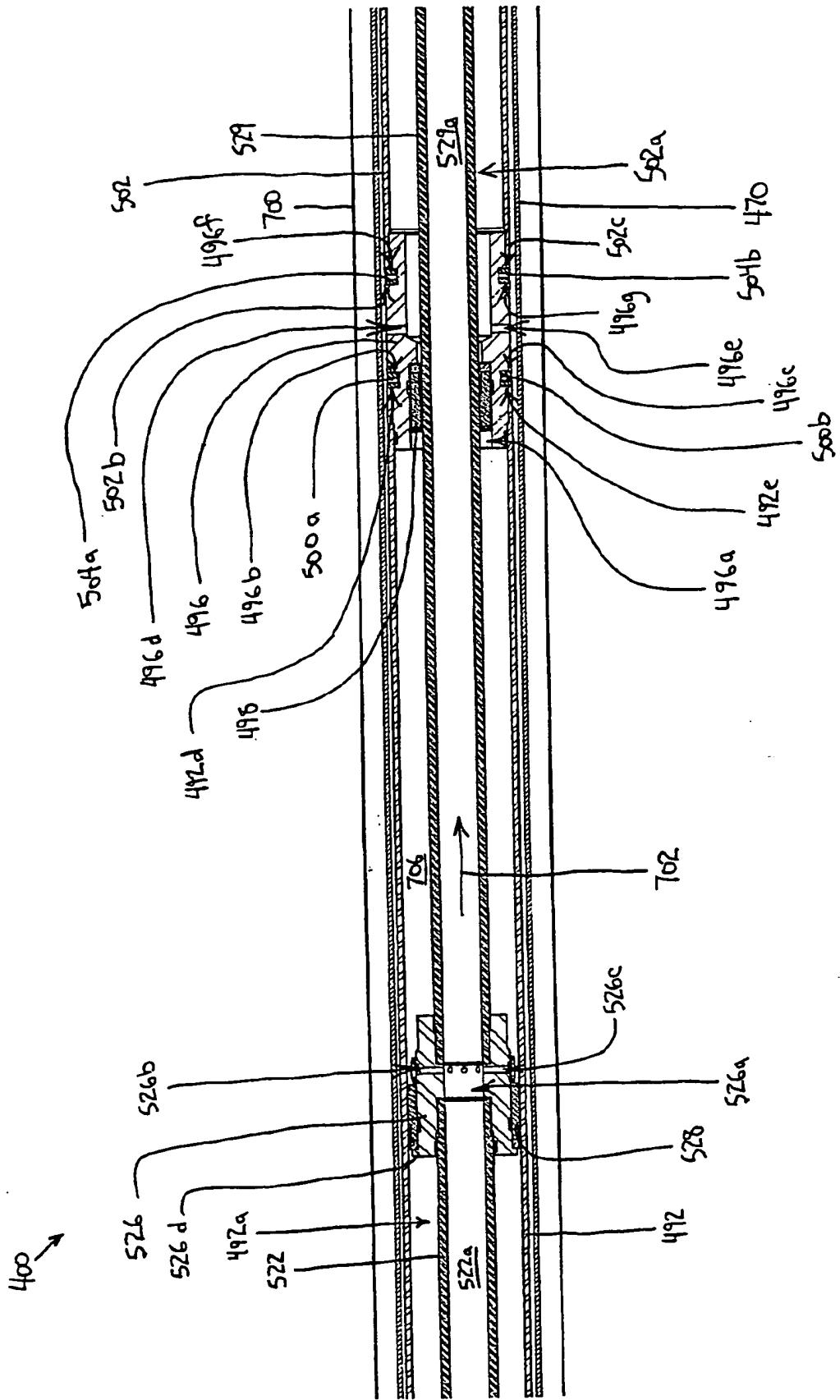

Fig. 29f

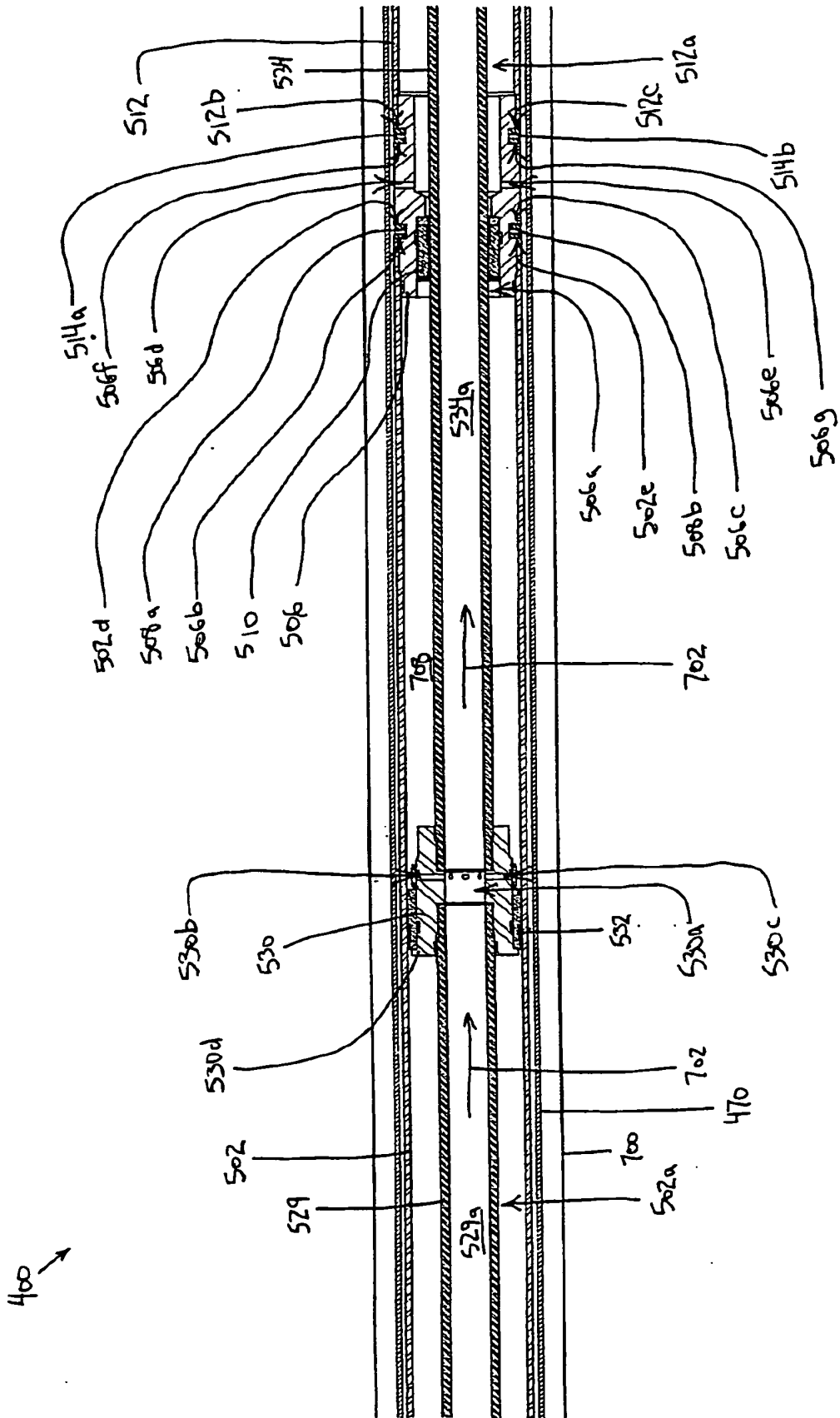

Fig. 29g

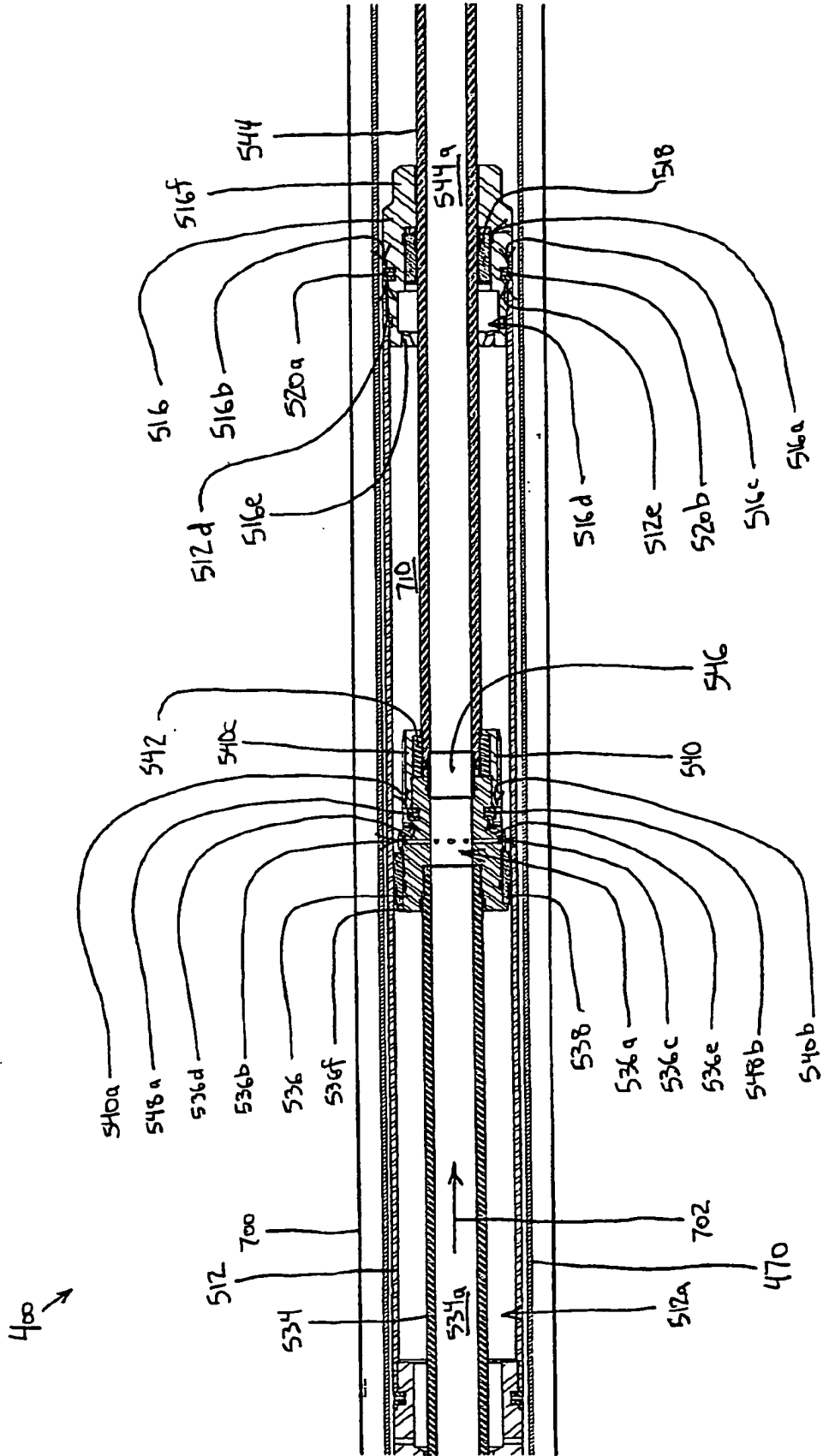

Fig. 20h



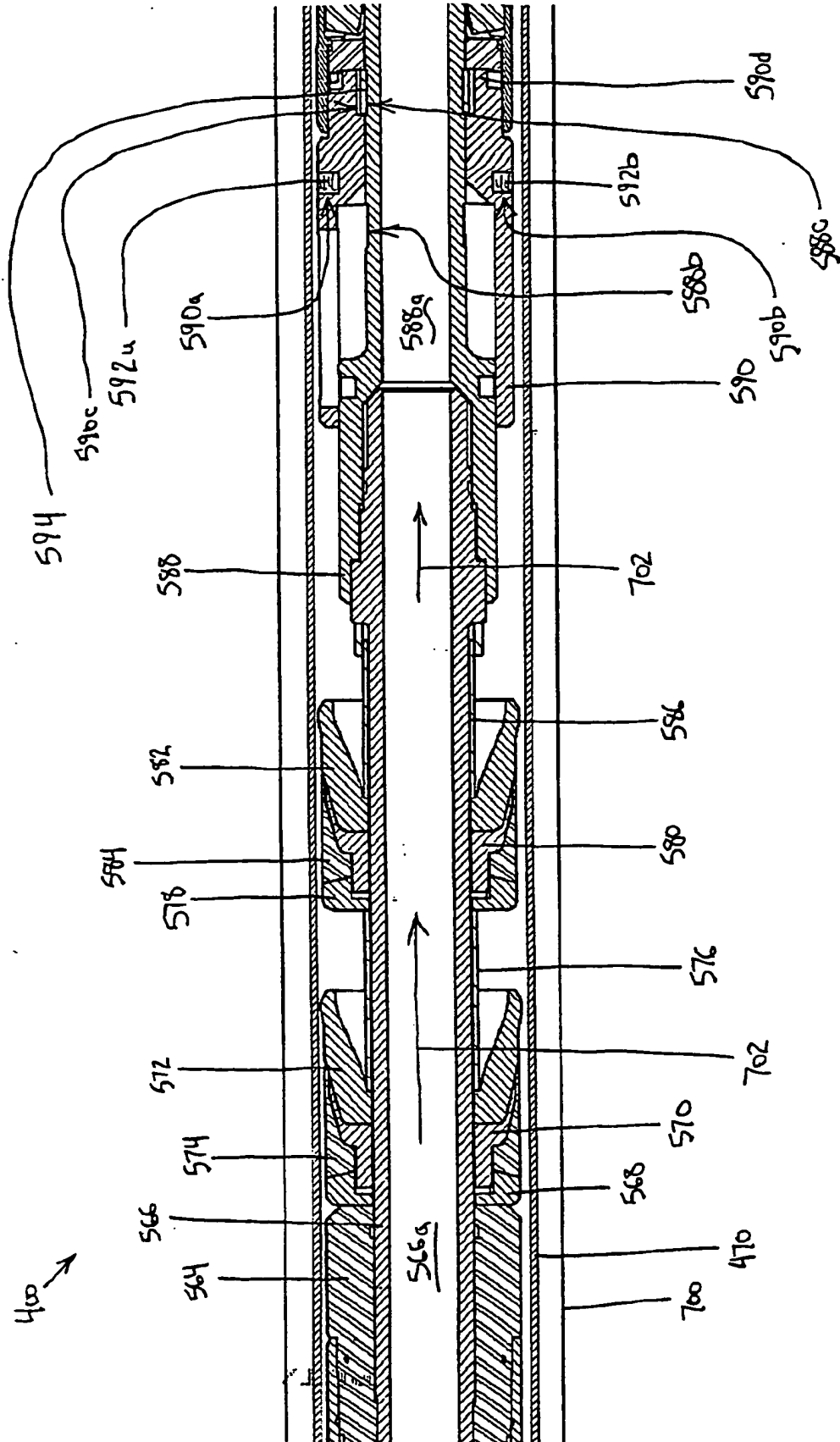

Fig. 29j



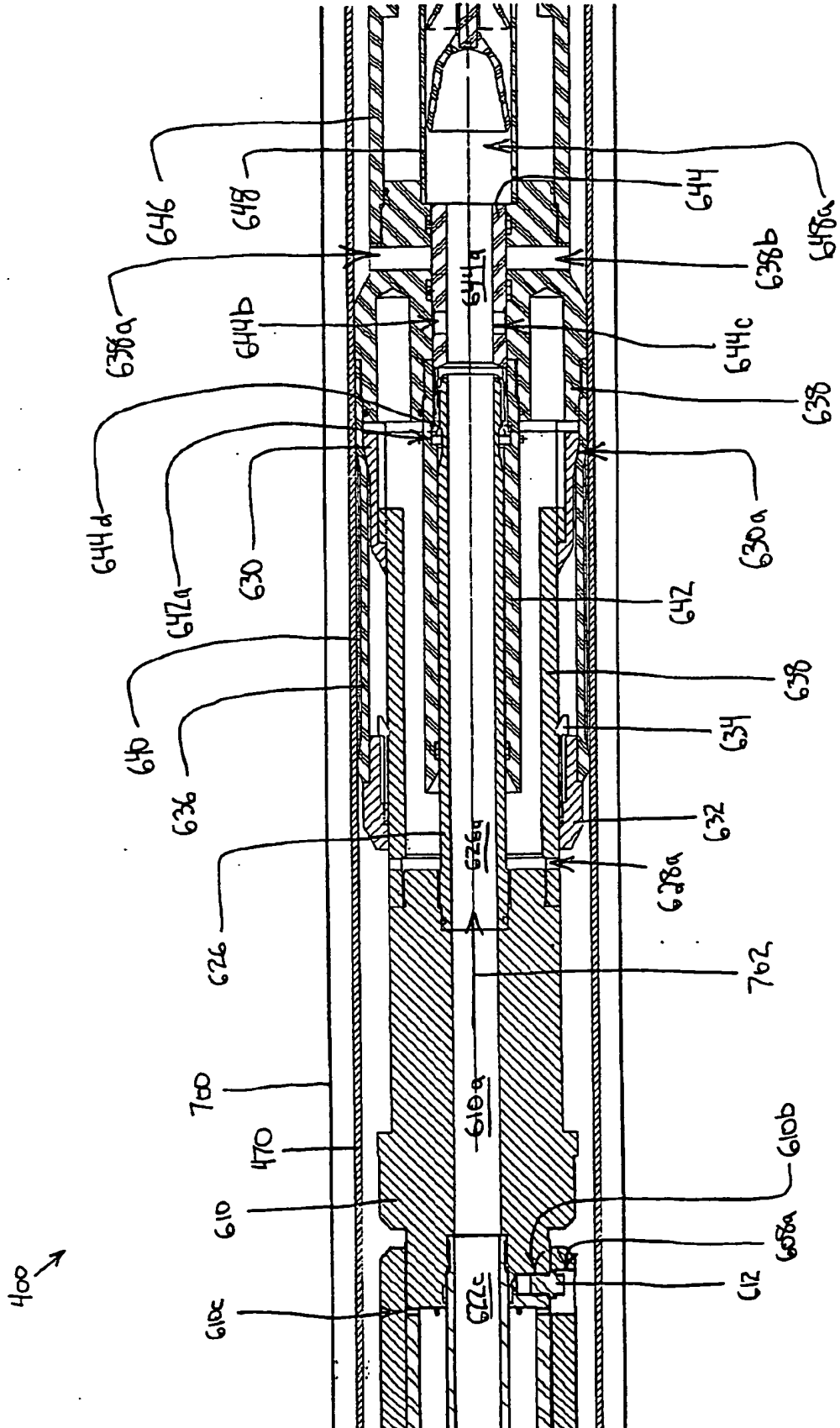

Fig. 29I











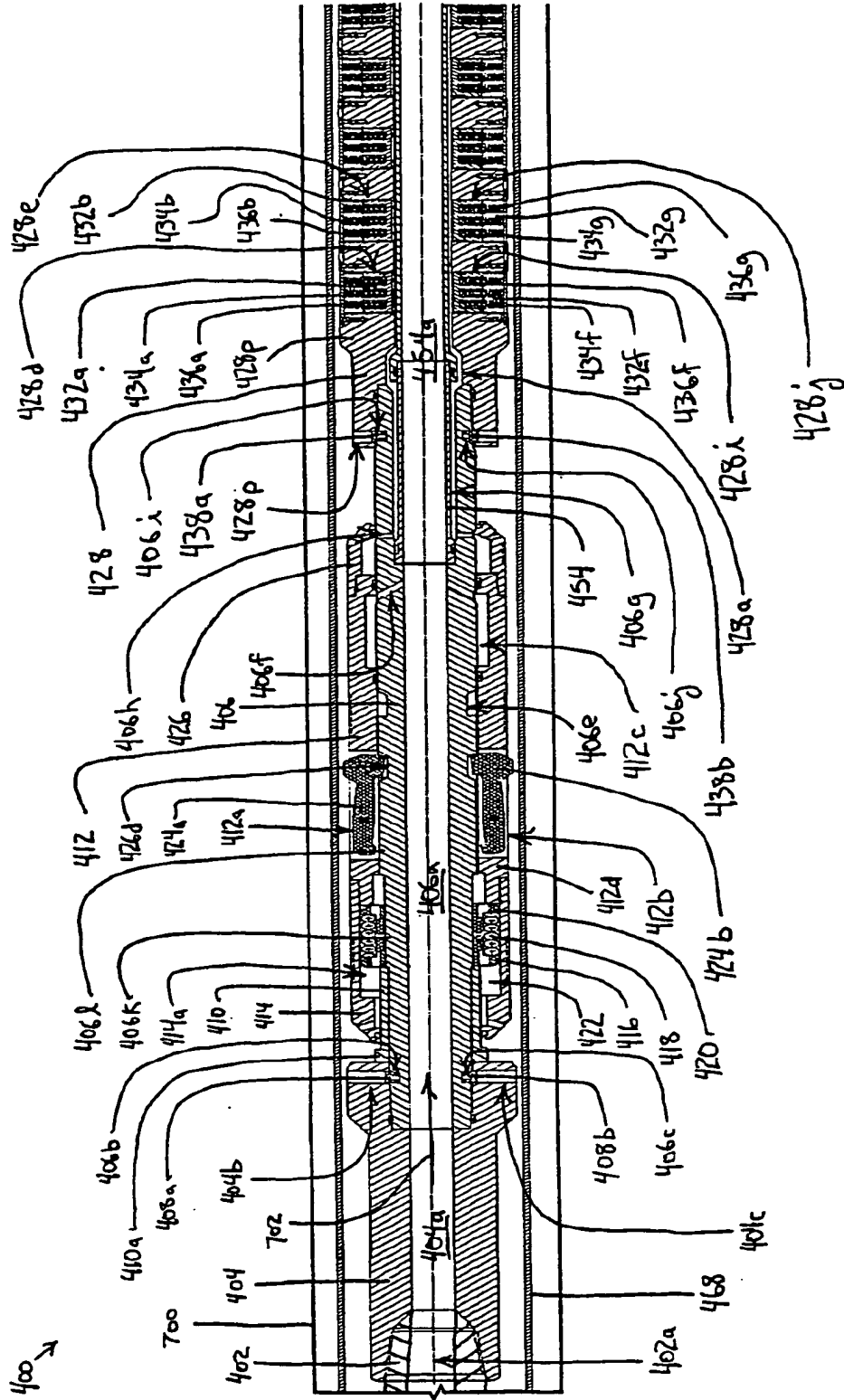

Fig. 31a

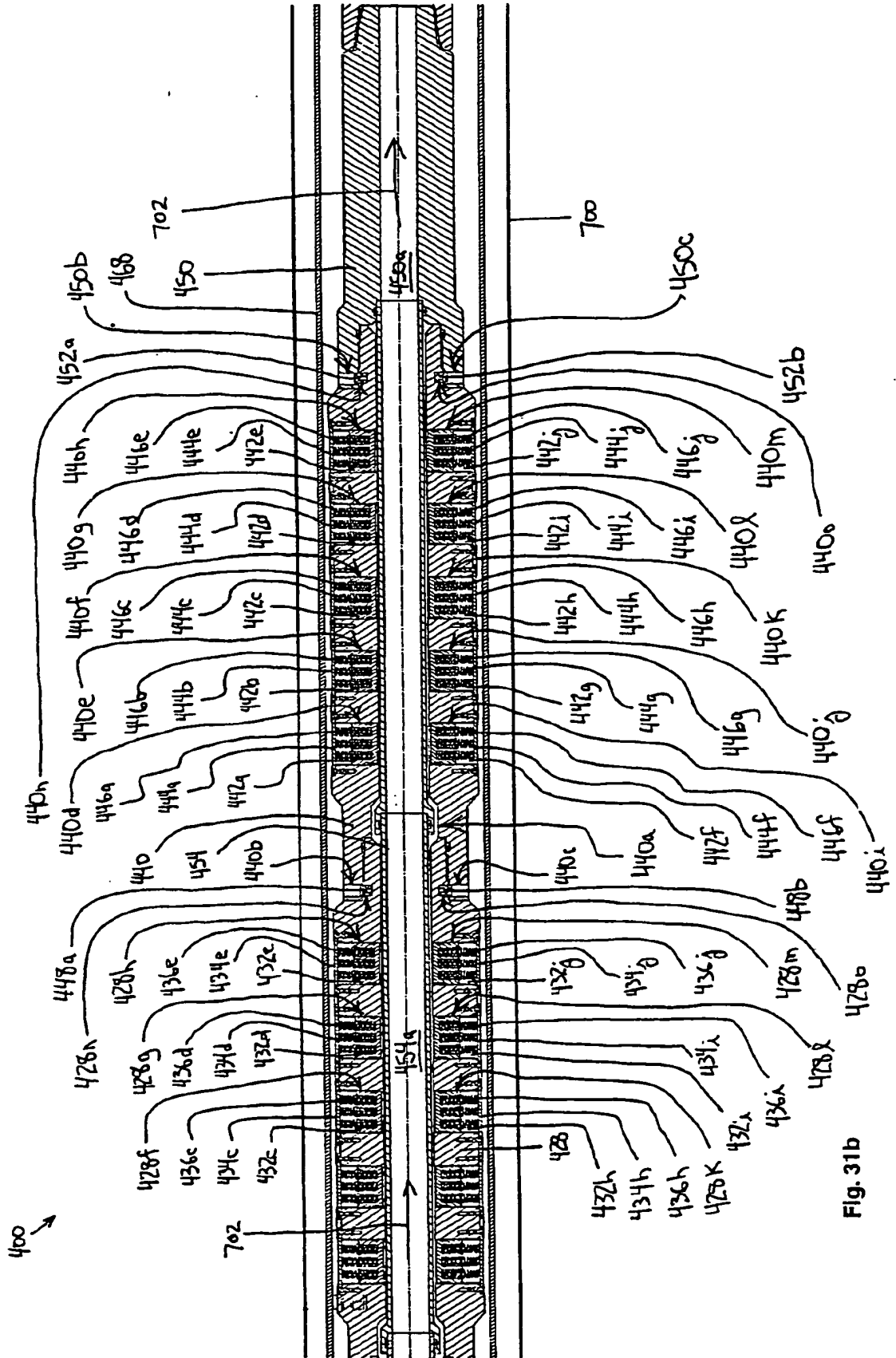

Fig. 31b

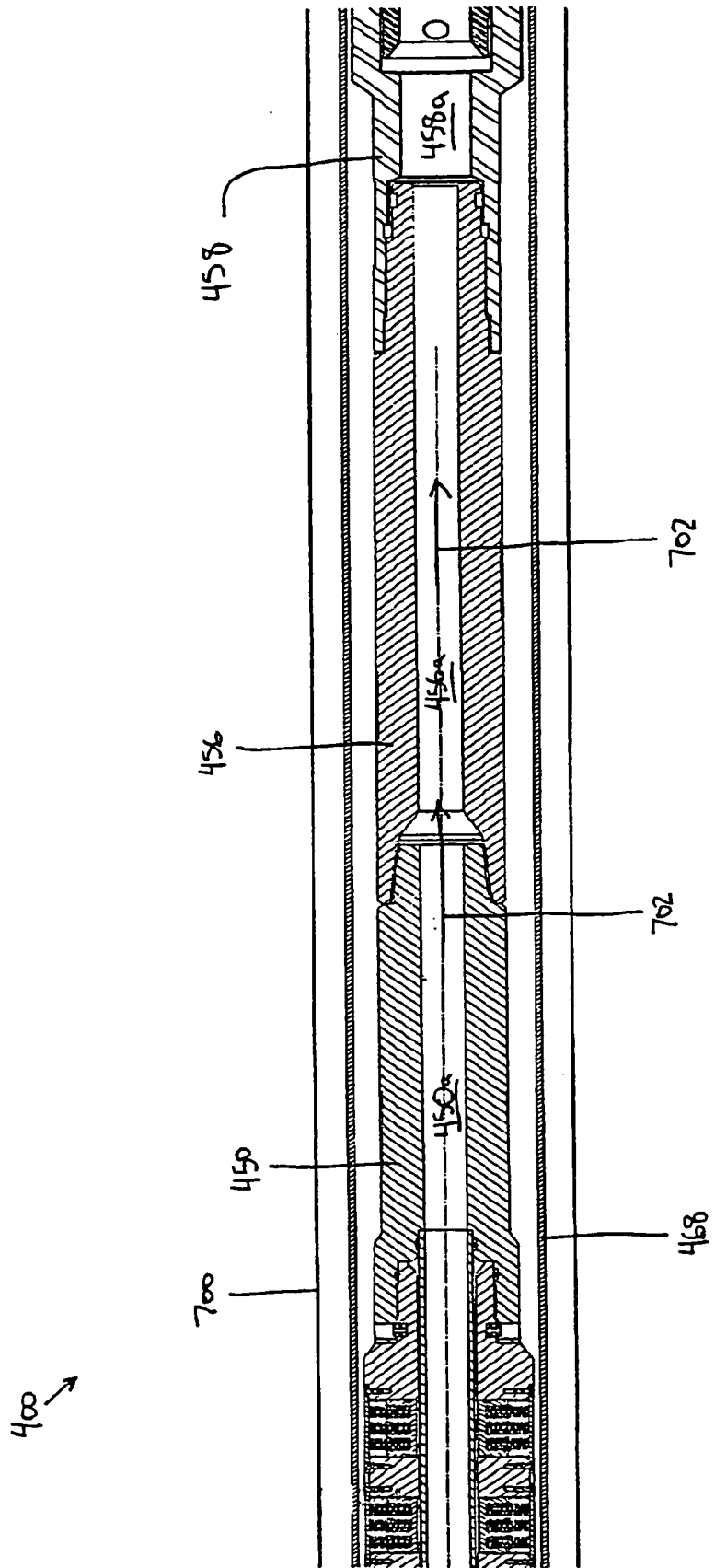

Fig. 31c

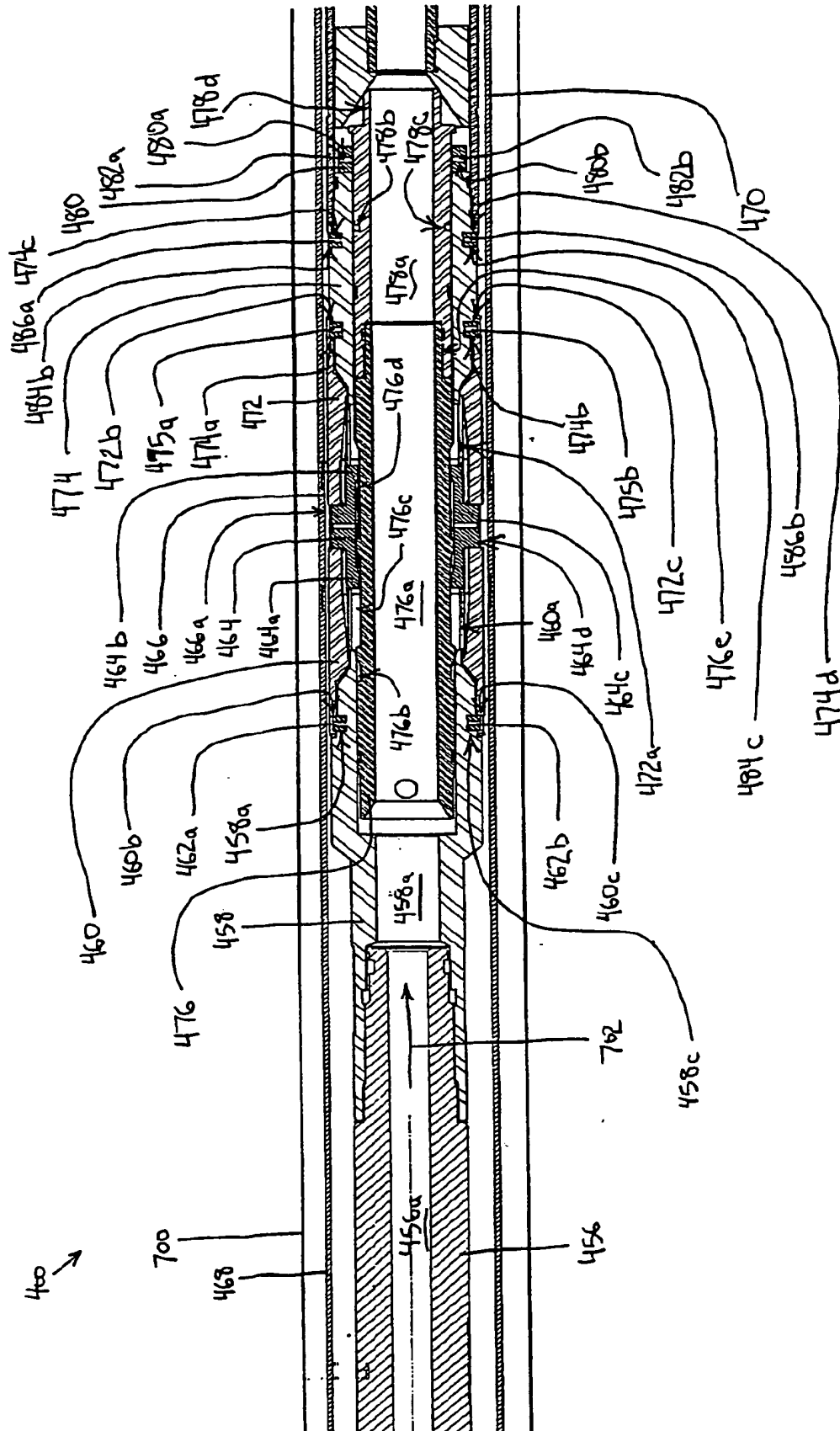

Fig. 31d





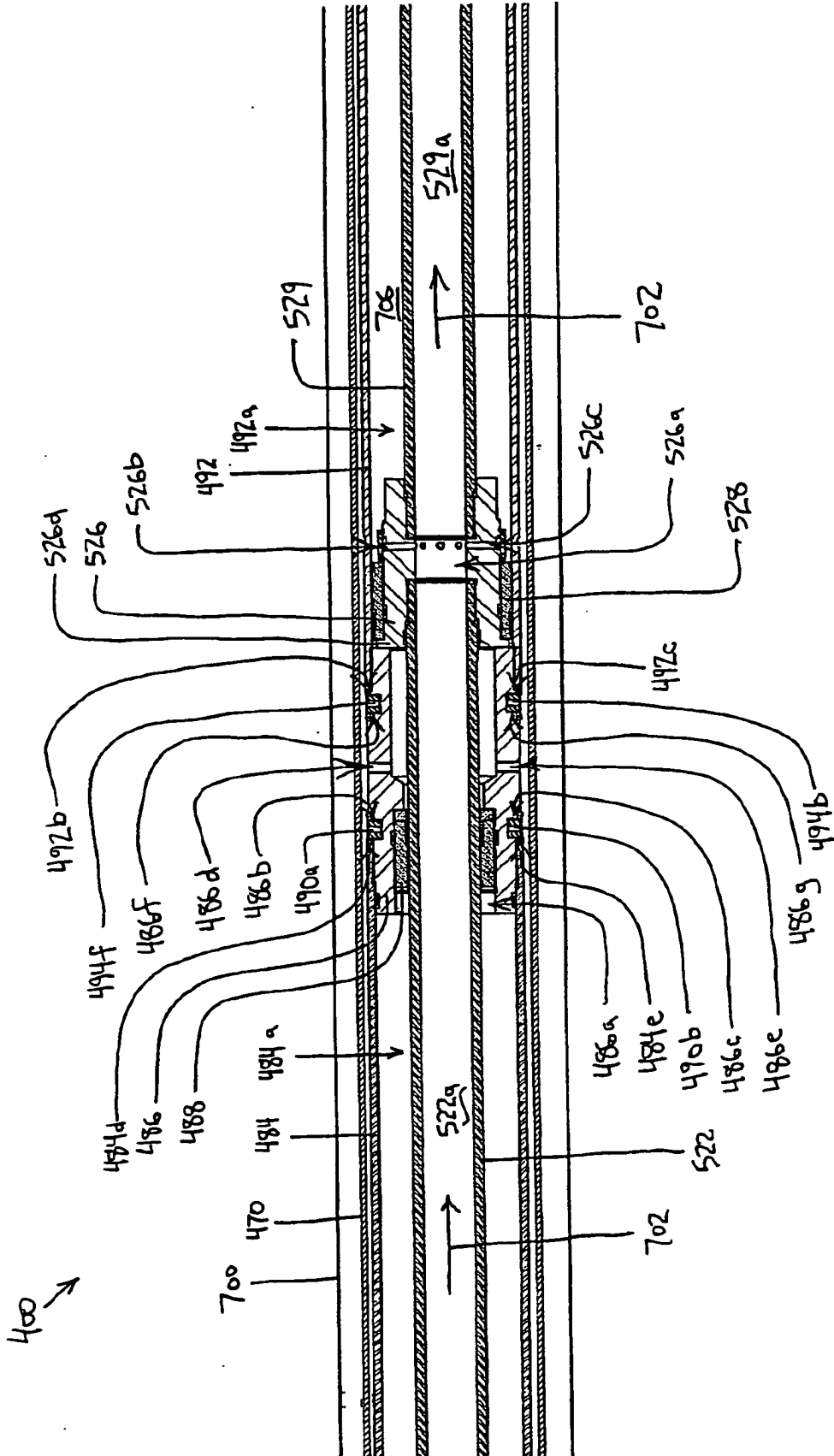

Fig. 31f

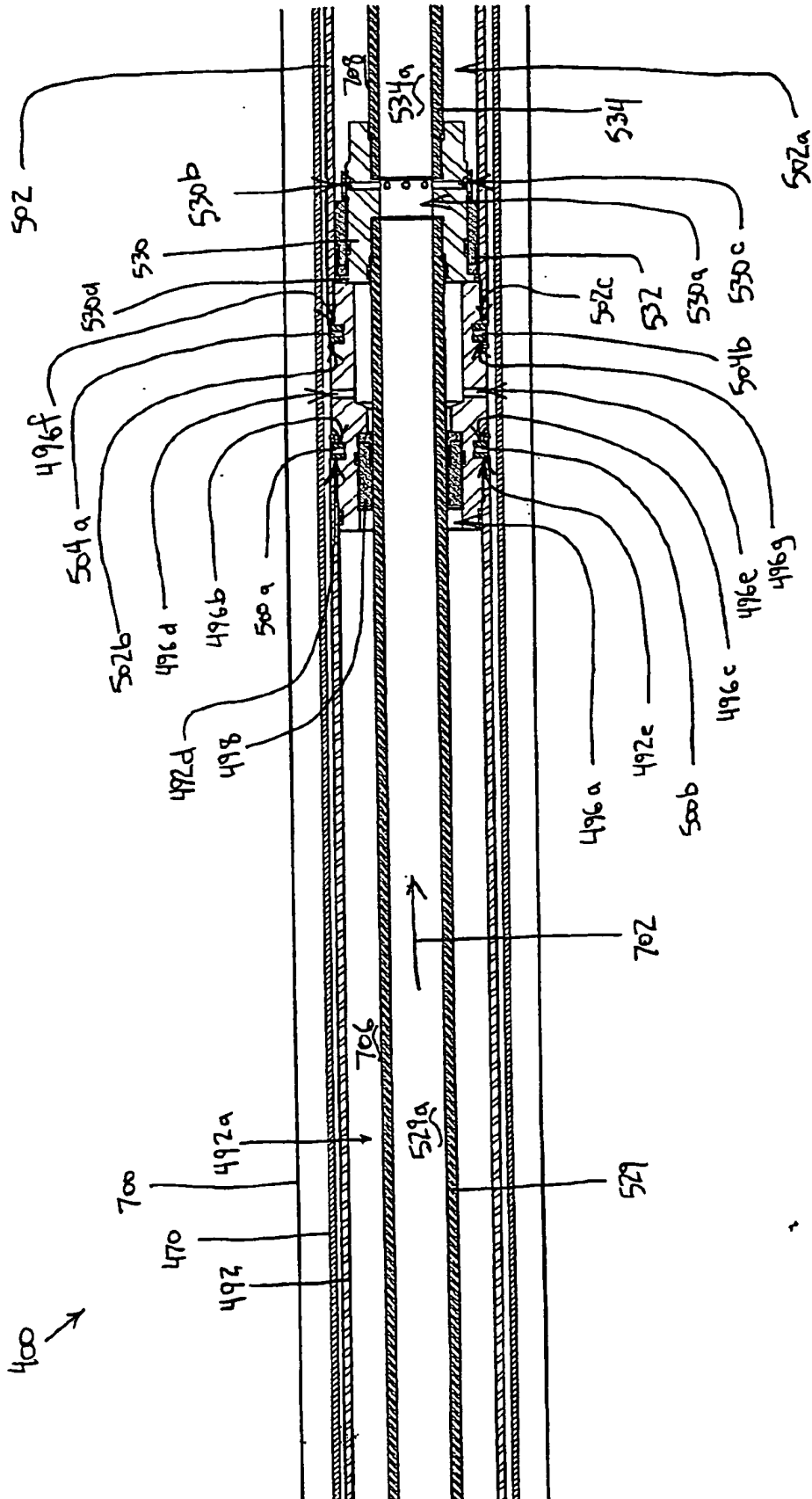

Fig. 31g

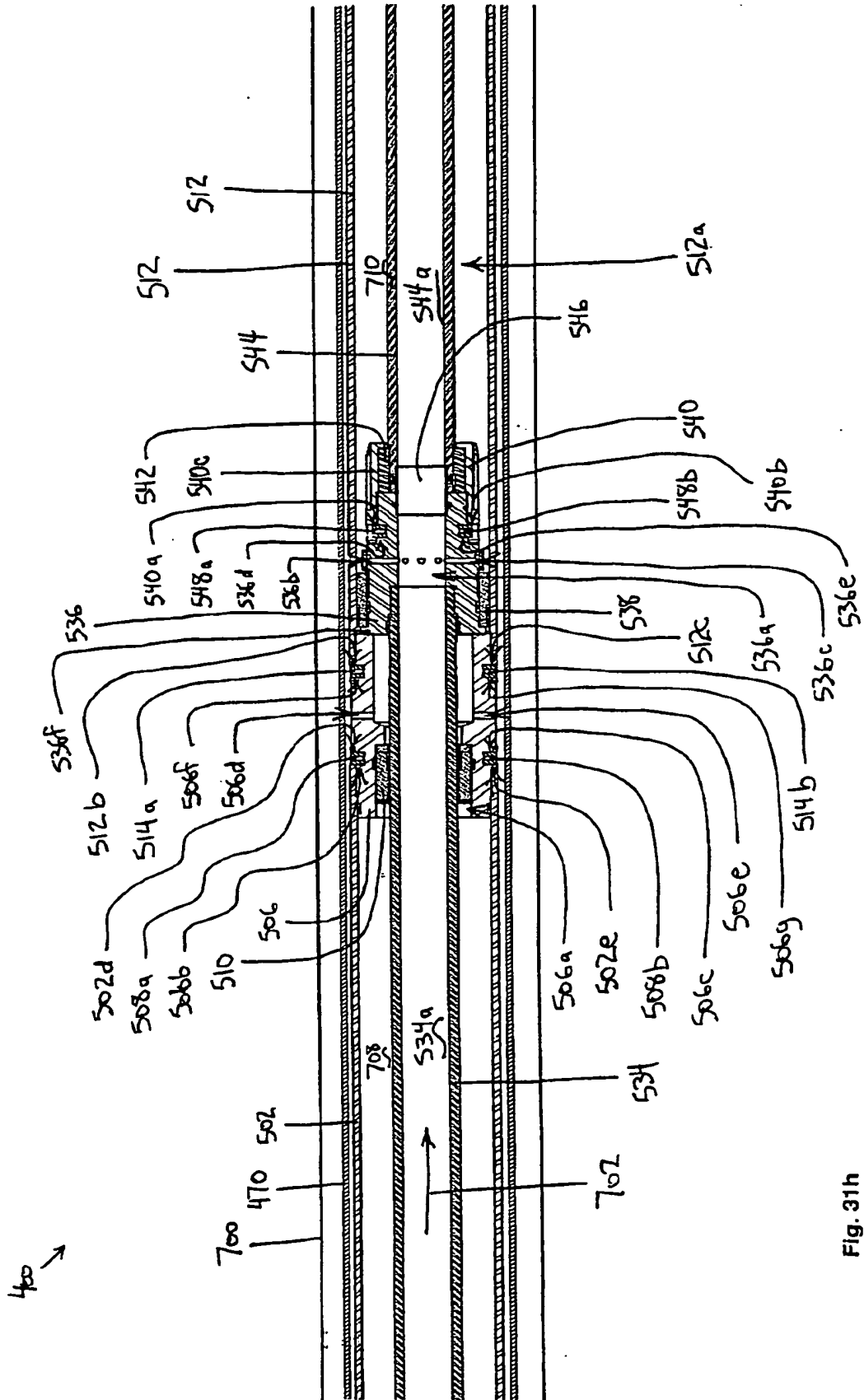

Fig. 31h



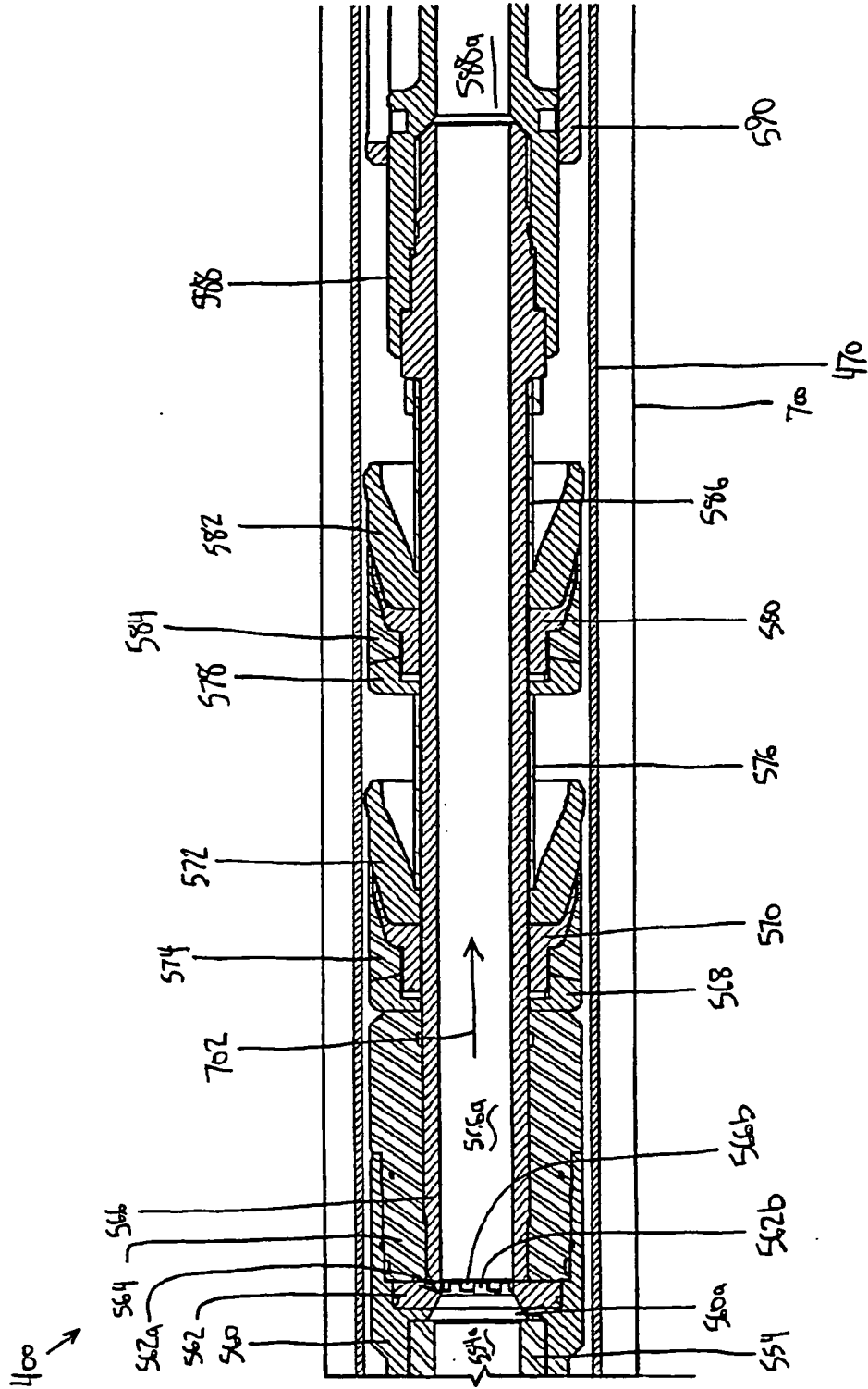

Fig. 31j

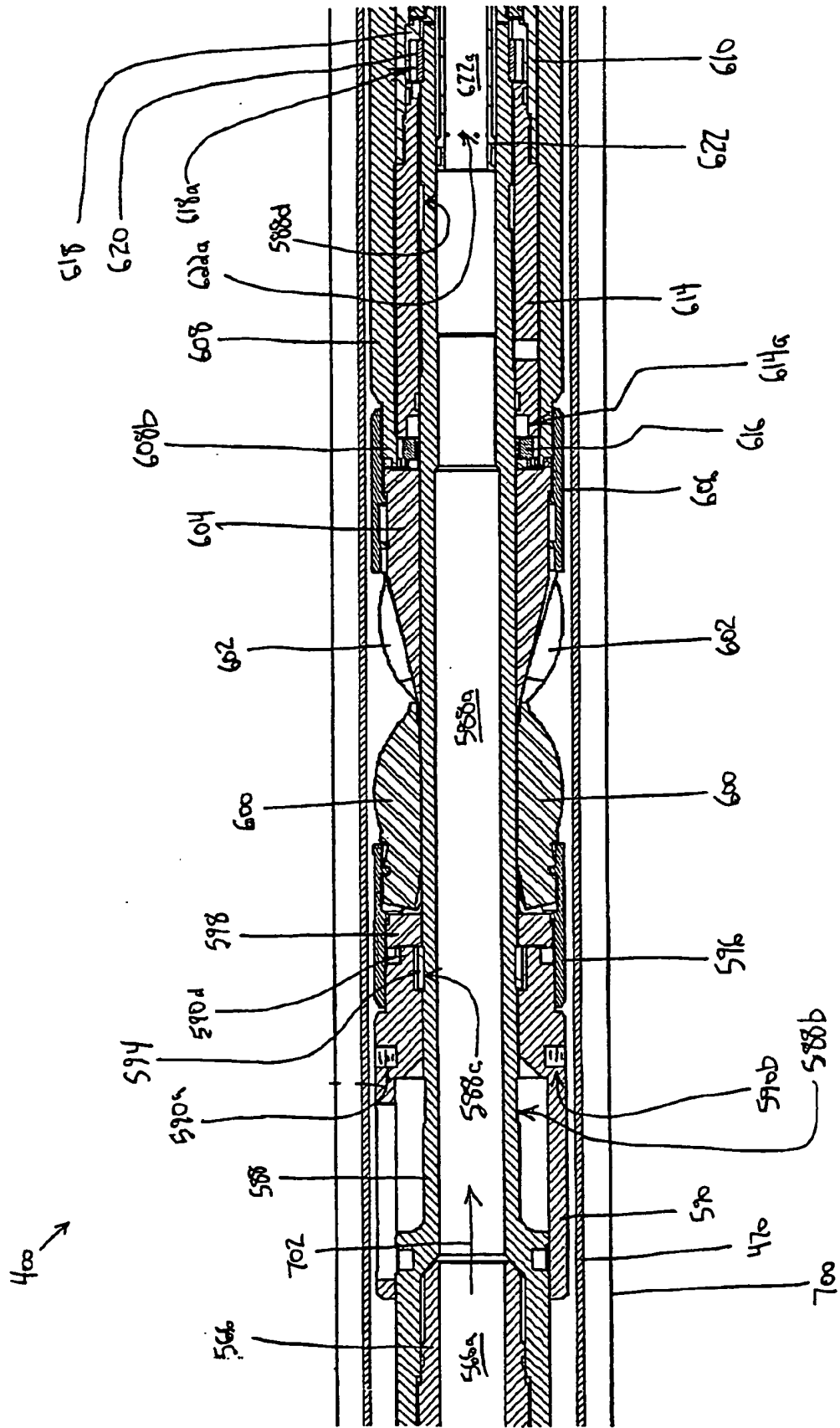

Fig. 31k

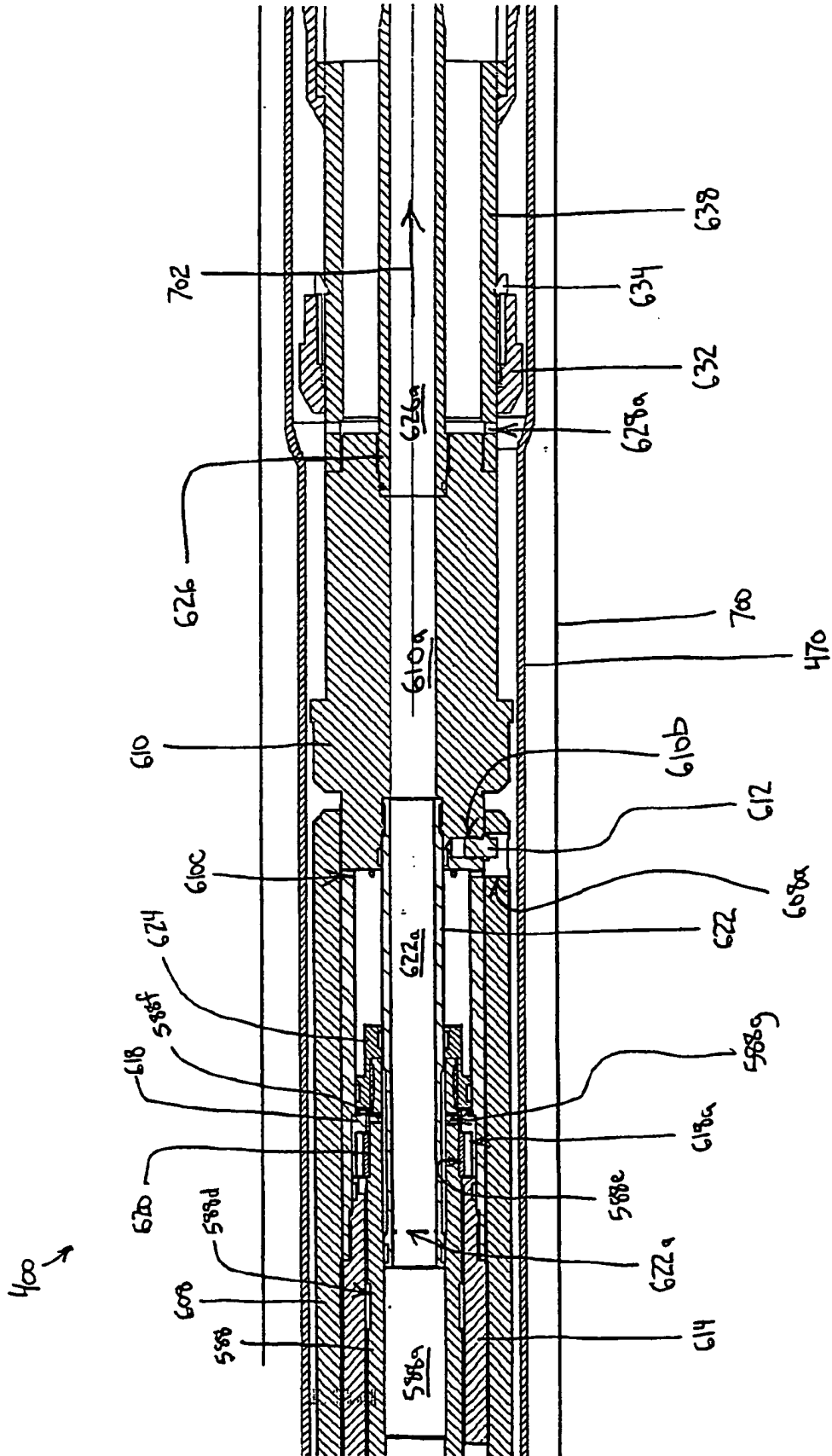

Fig. 311

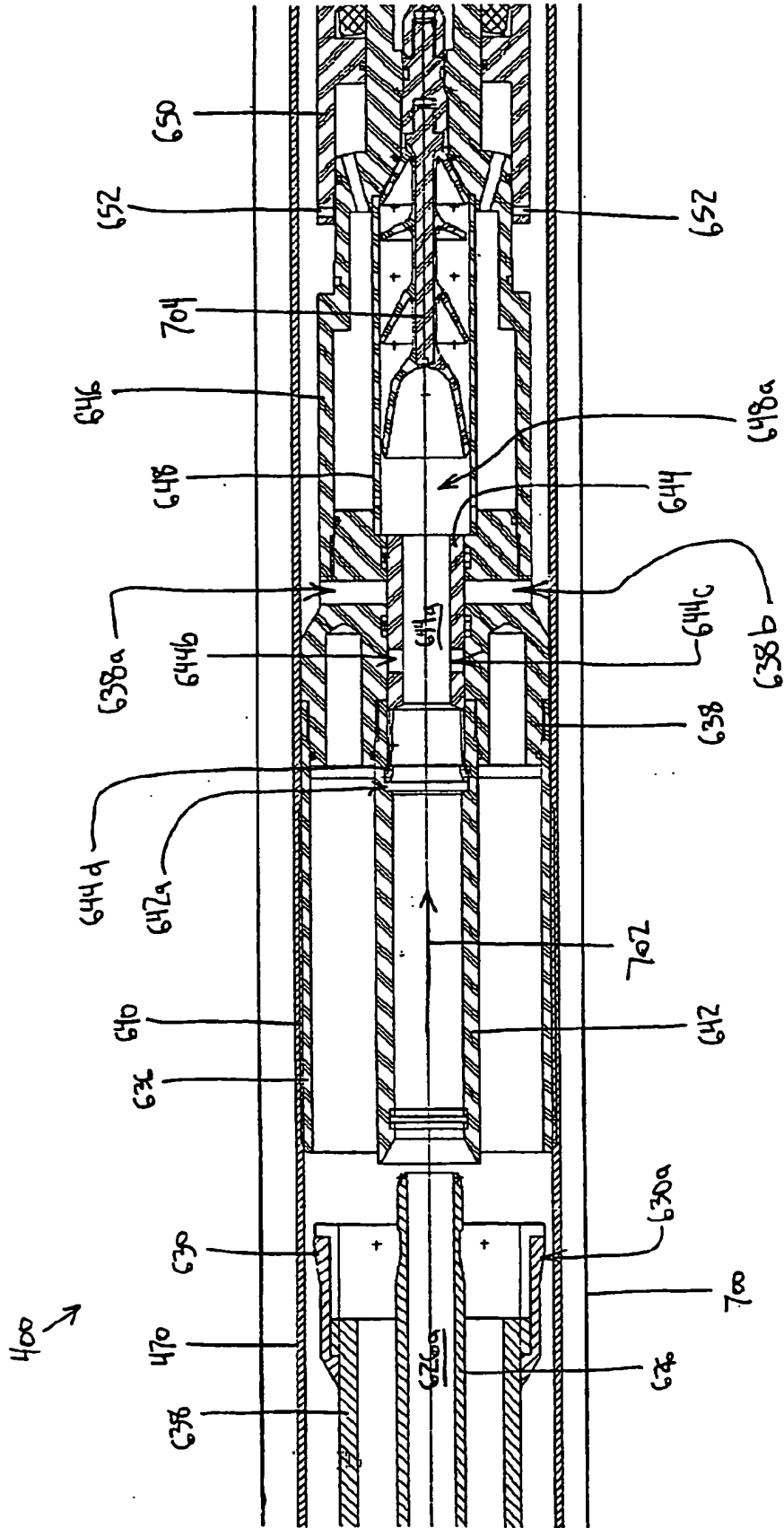

Fig. 31m



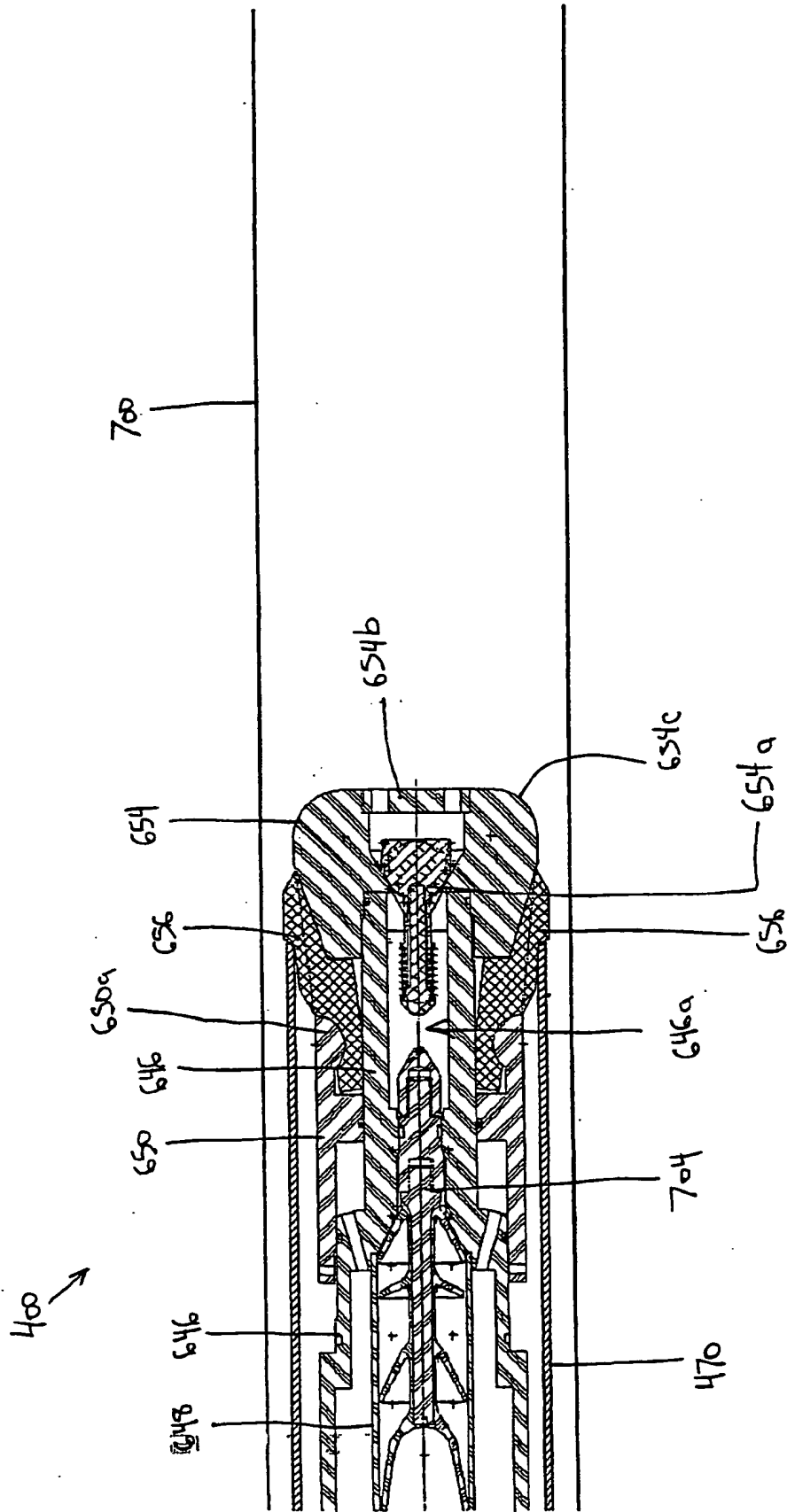

Fig. 31n



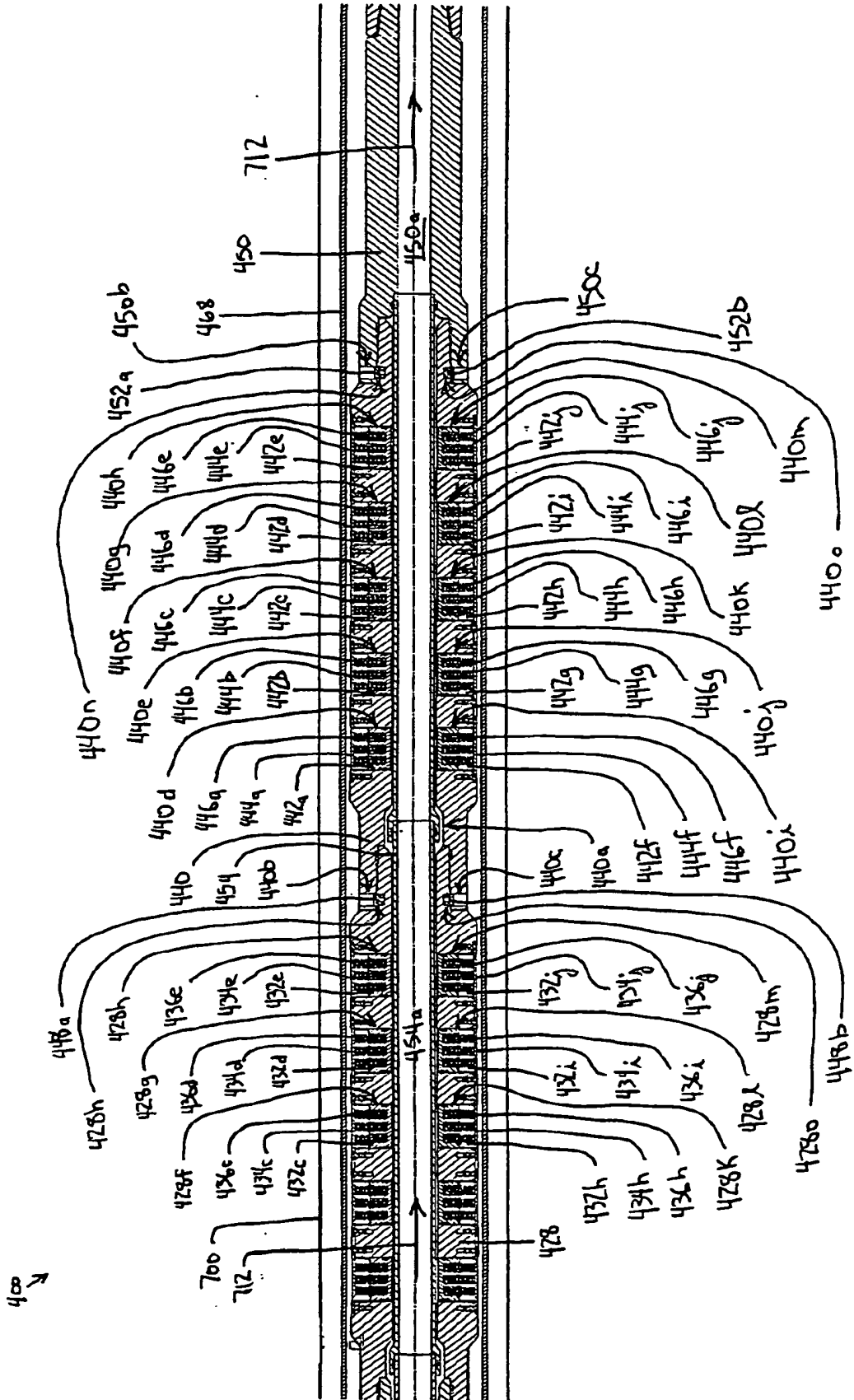

Fig. 32b

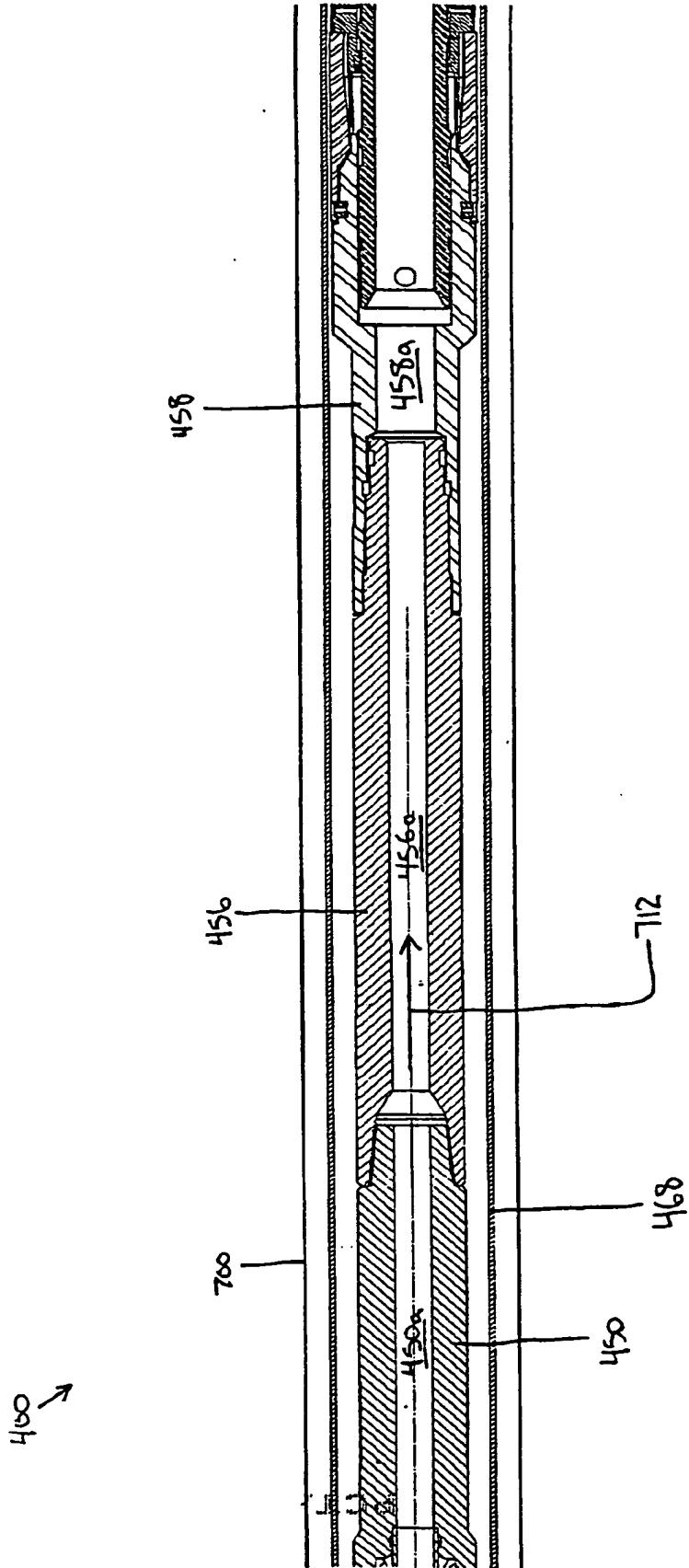

Fig. 32c

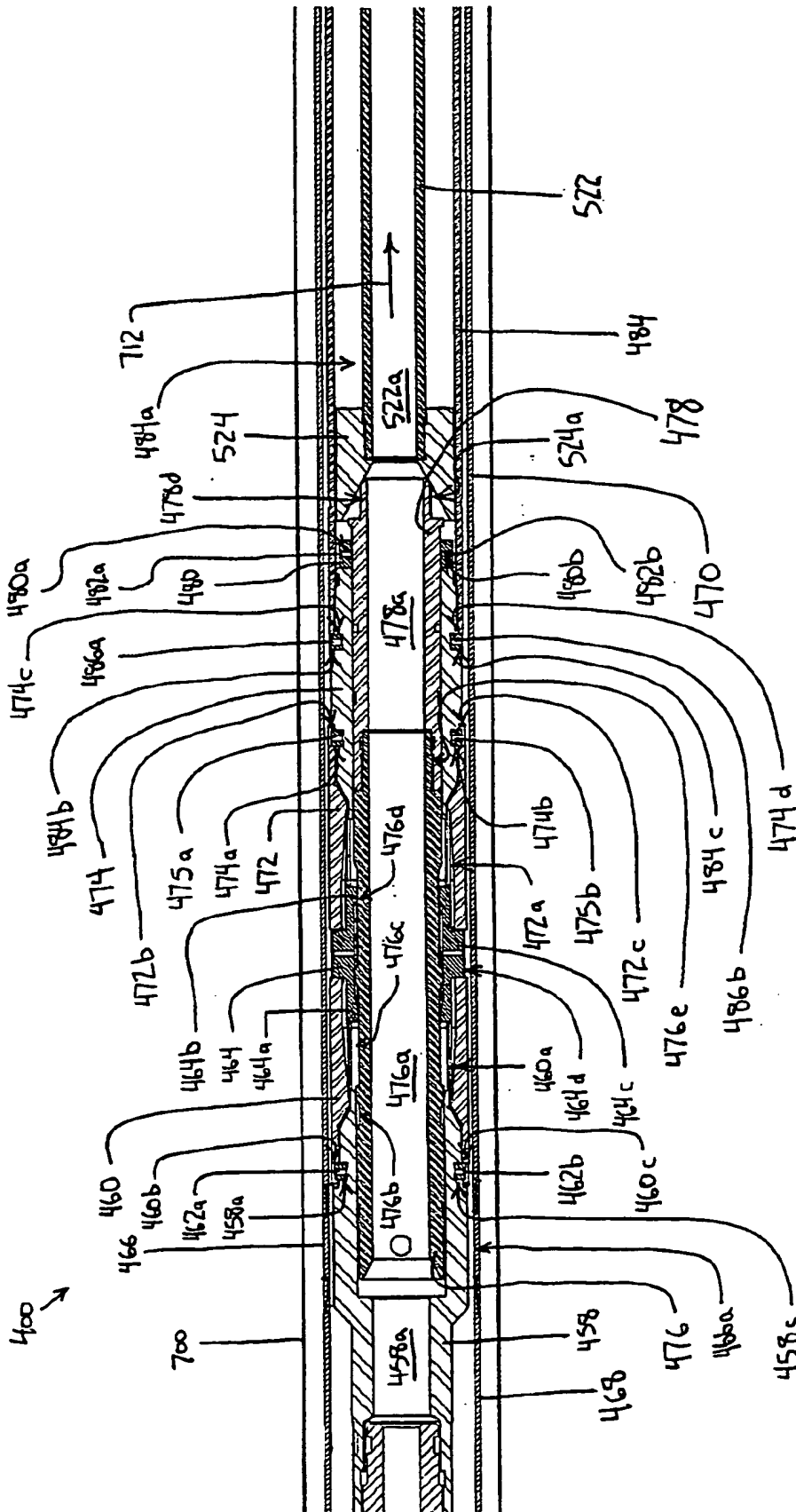

Fig. 32d



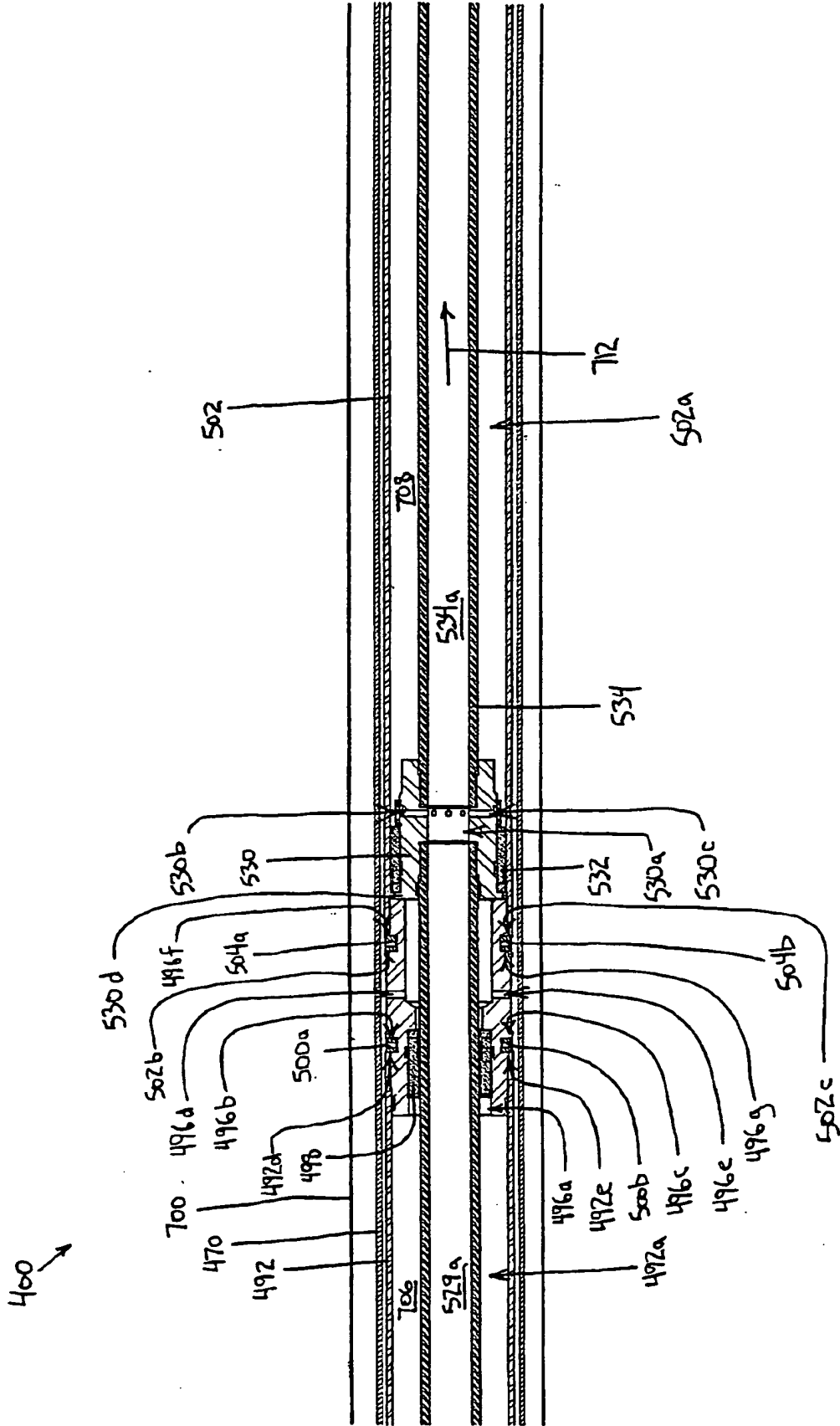

Fig. 32f

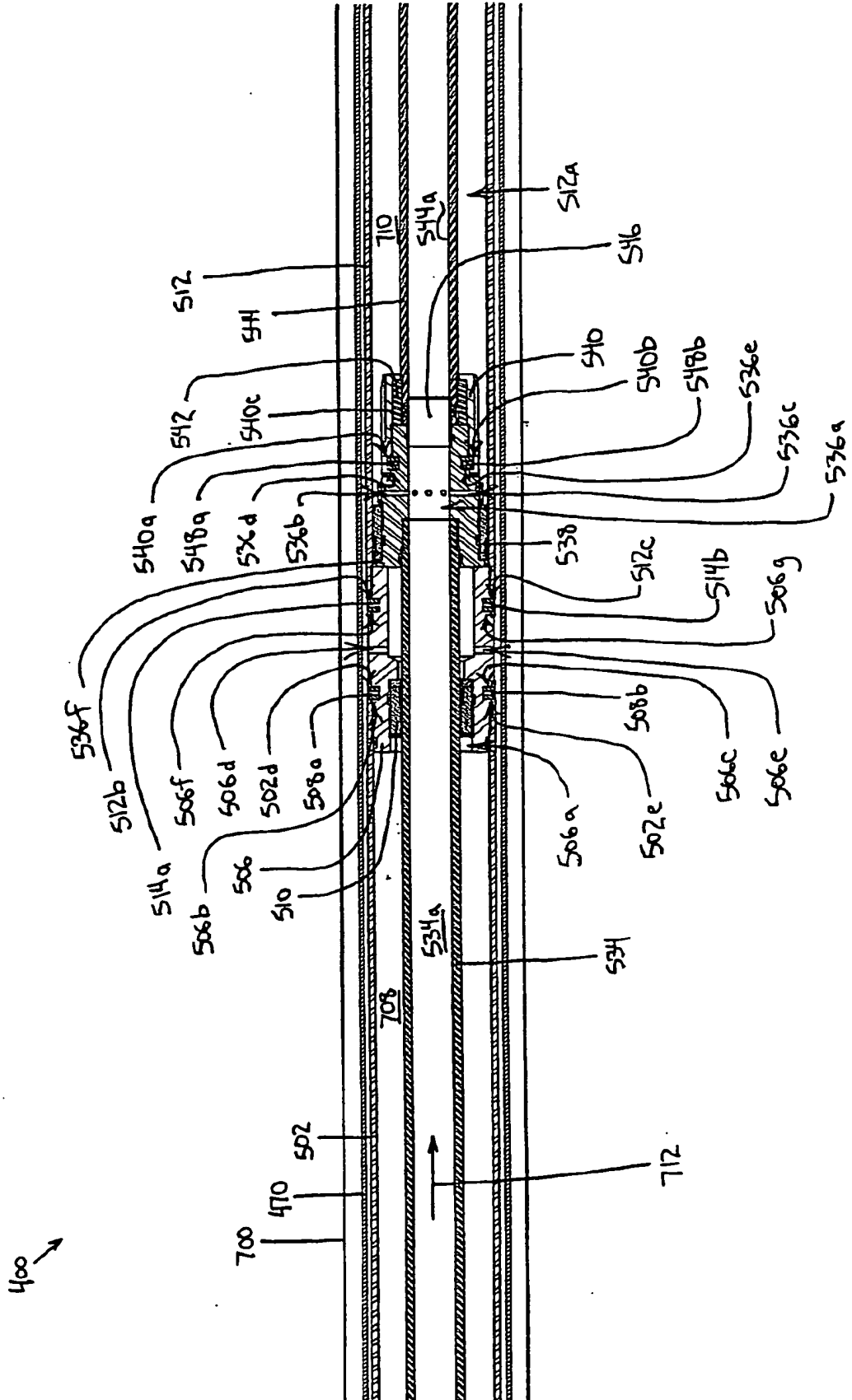

Fig. 32g



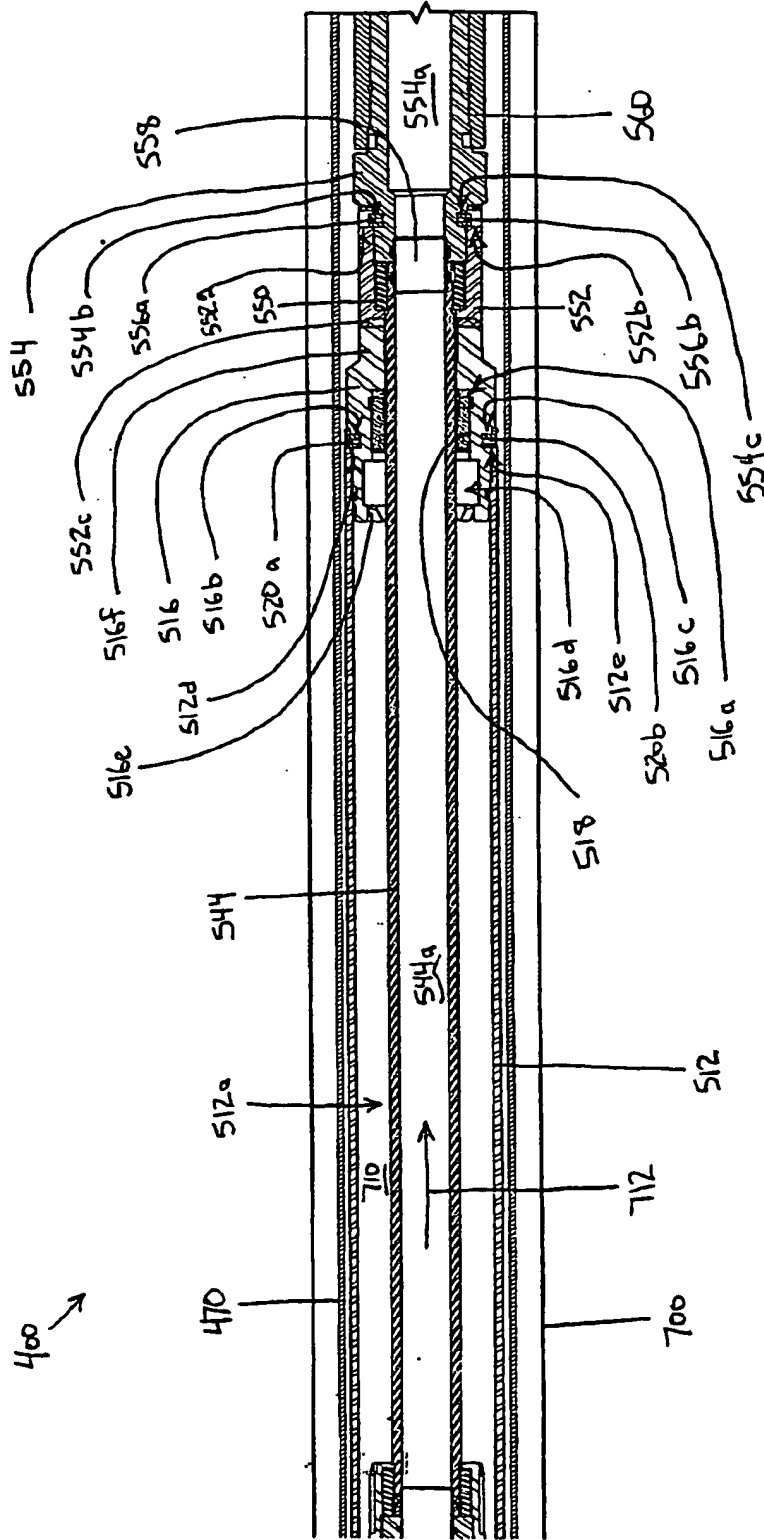

Fig. 32h



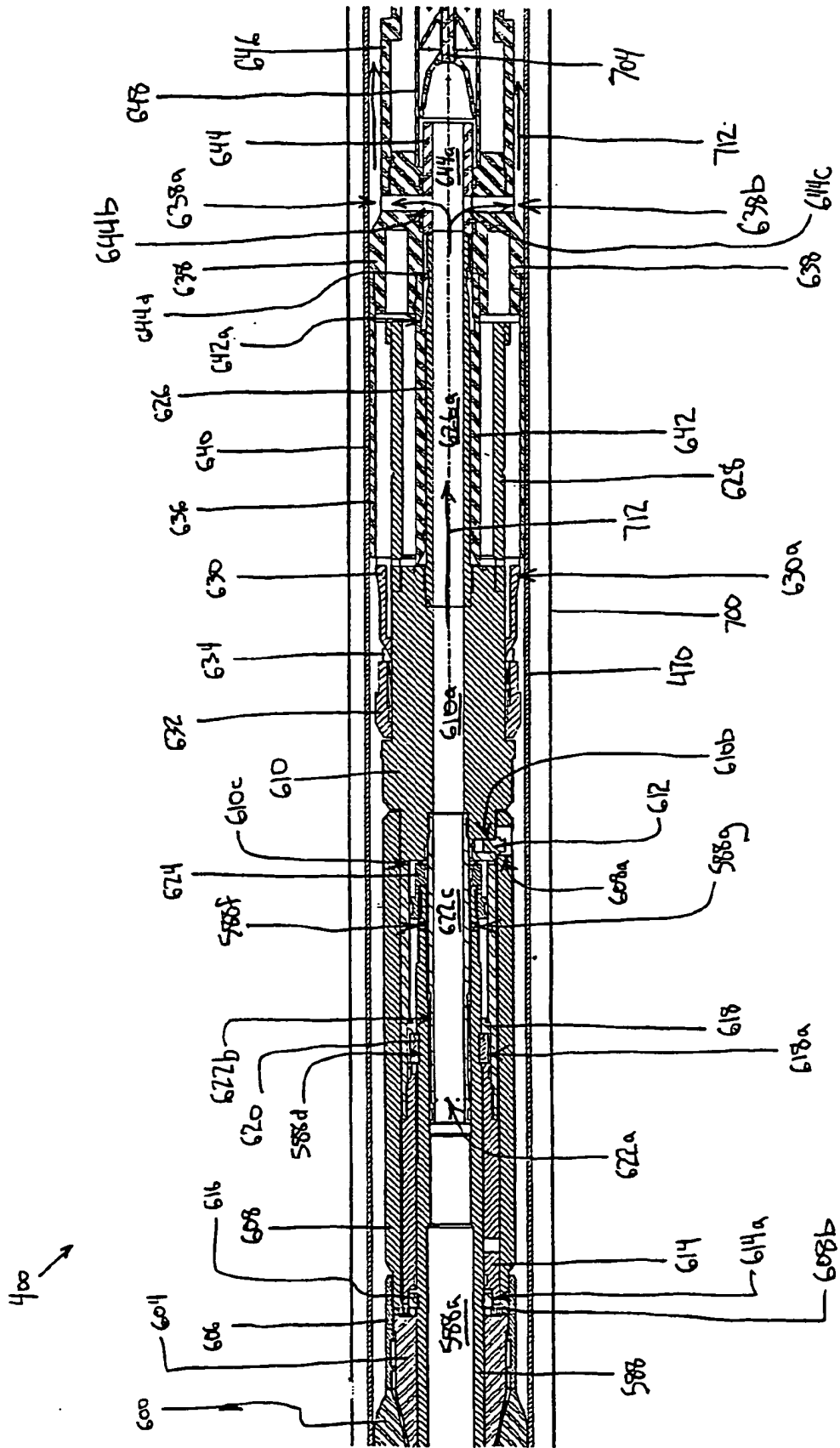

Fig. 32j



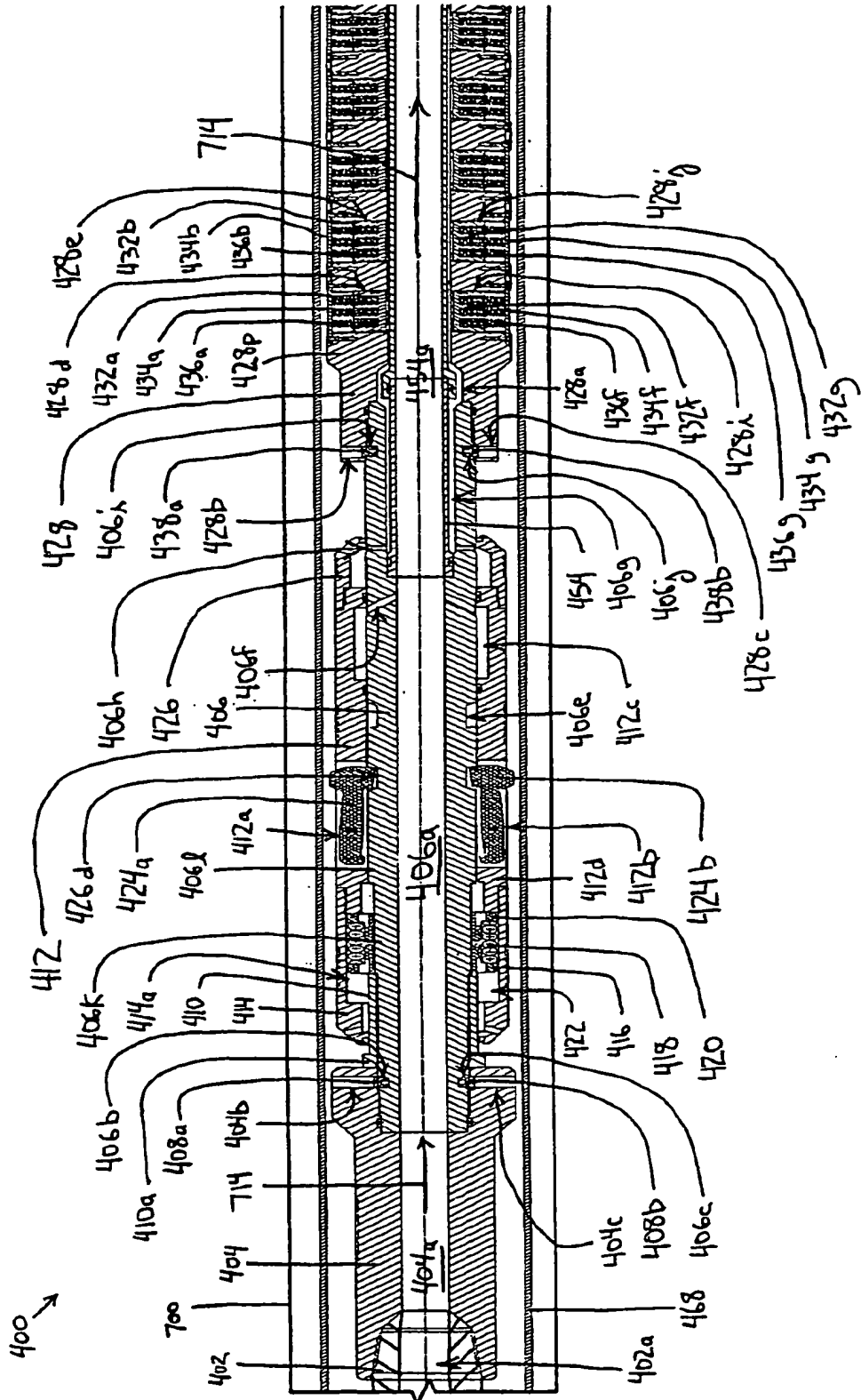

Fig. 33a

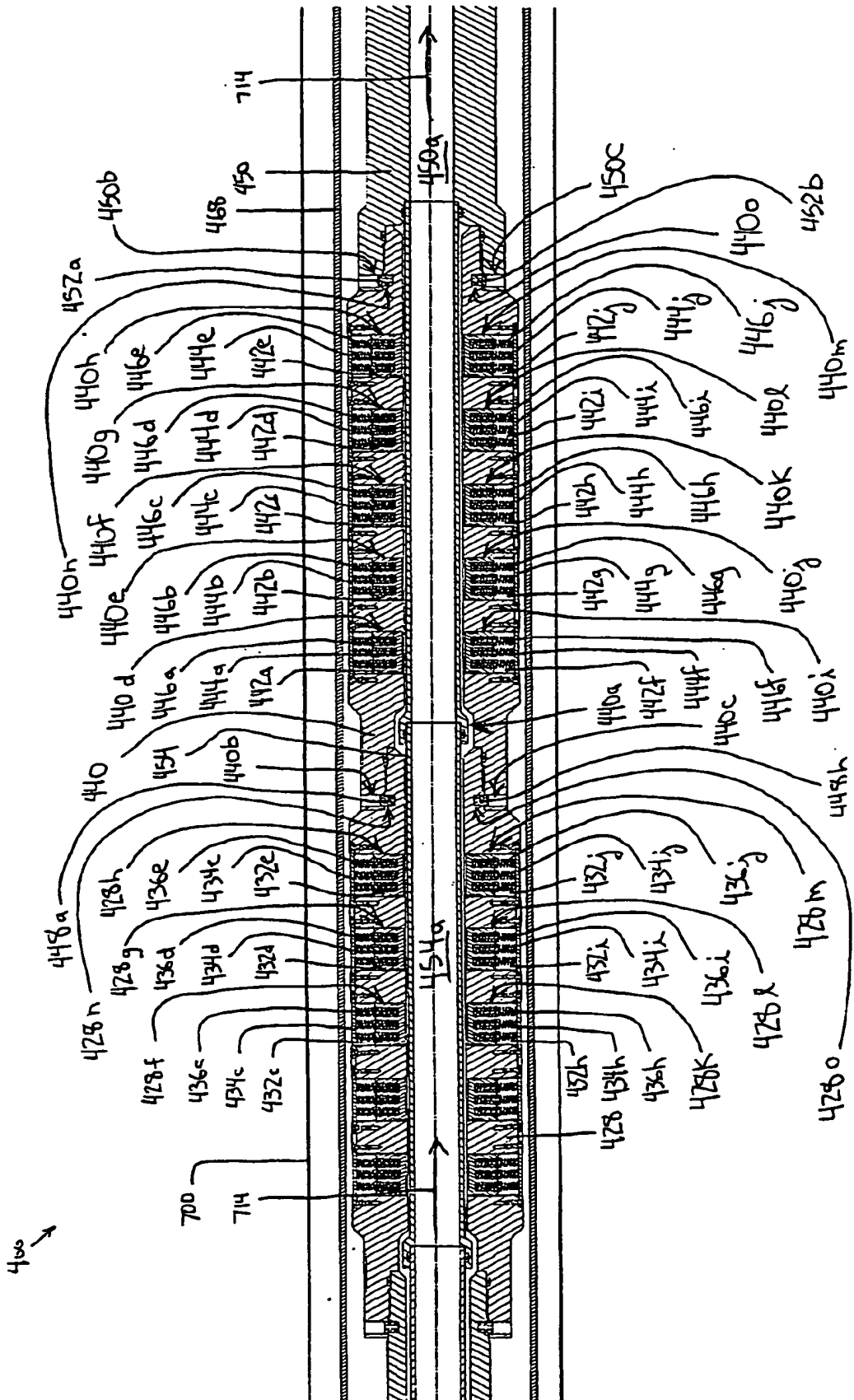

Fig. 33b

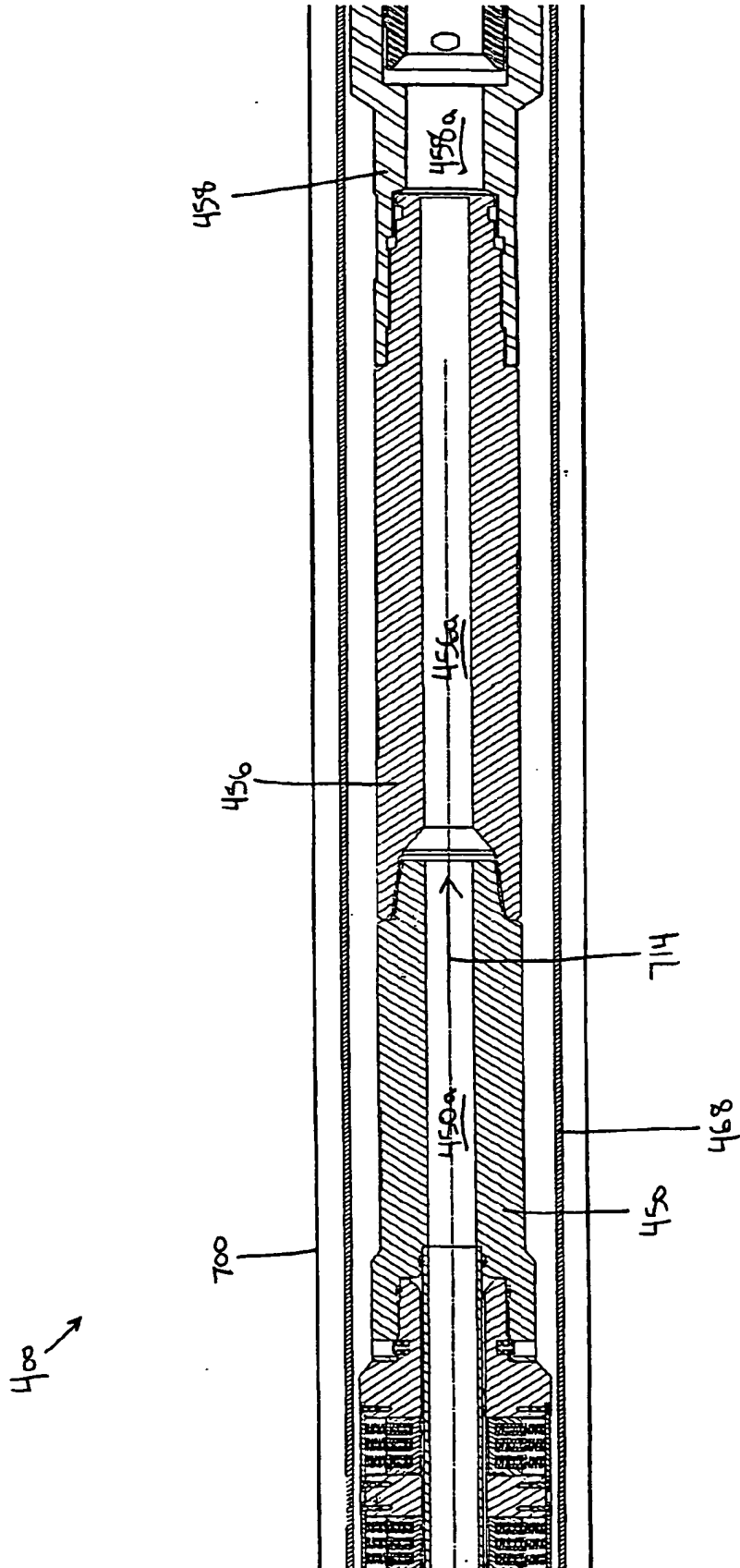

Fig. 33c





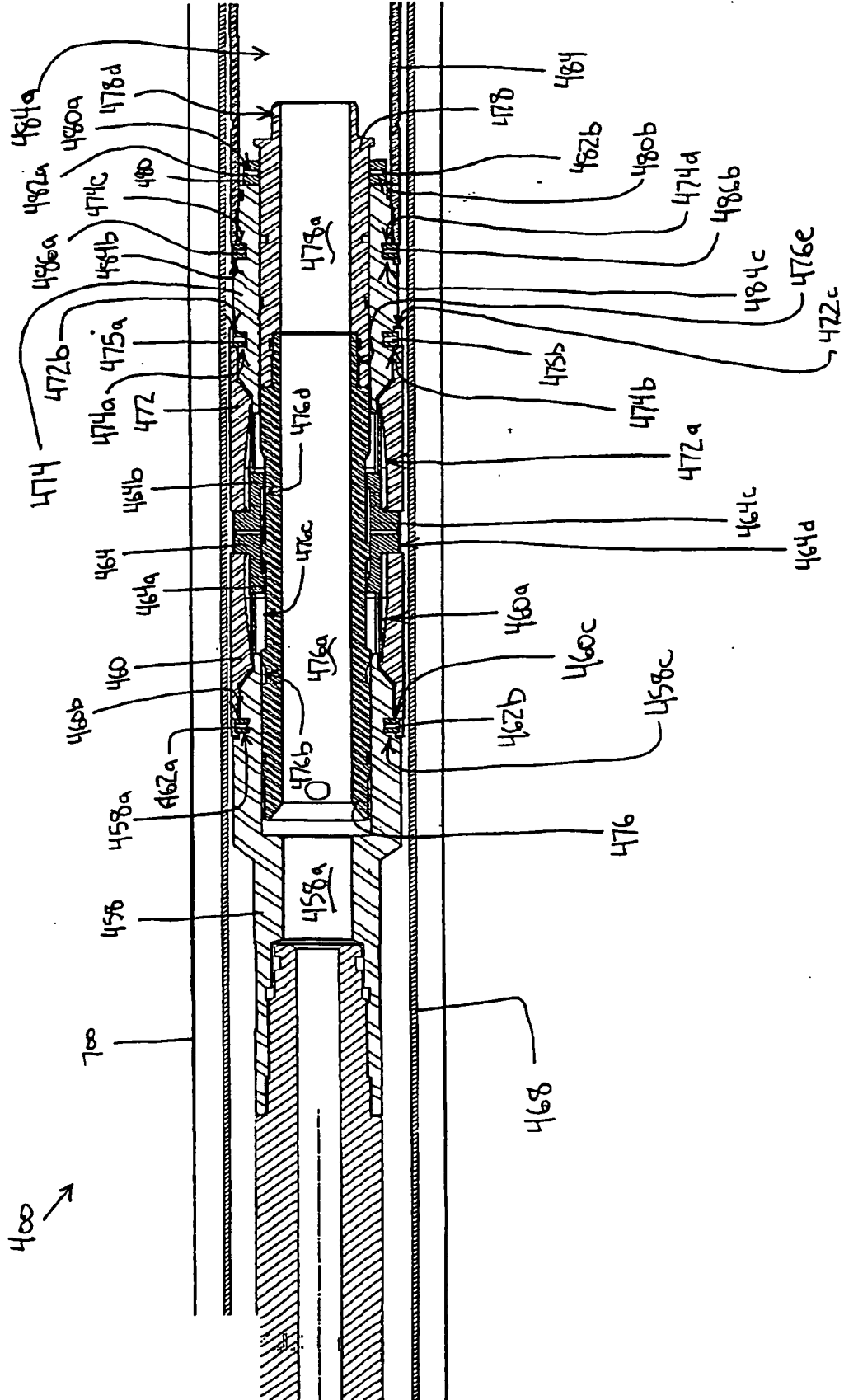

Fig. 33d



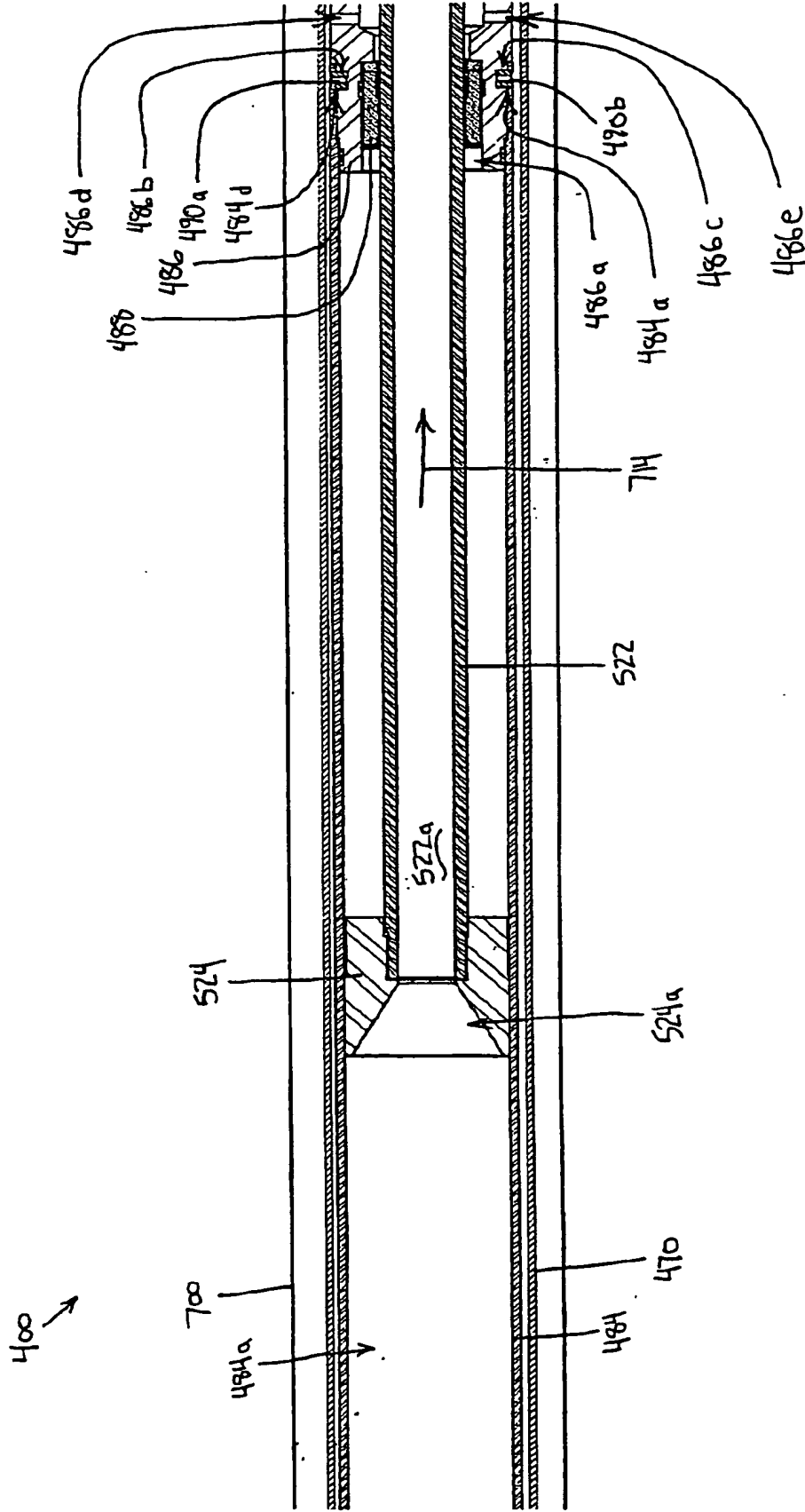

Fig. 33f



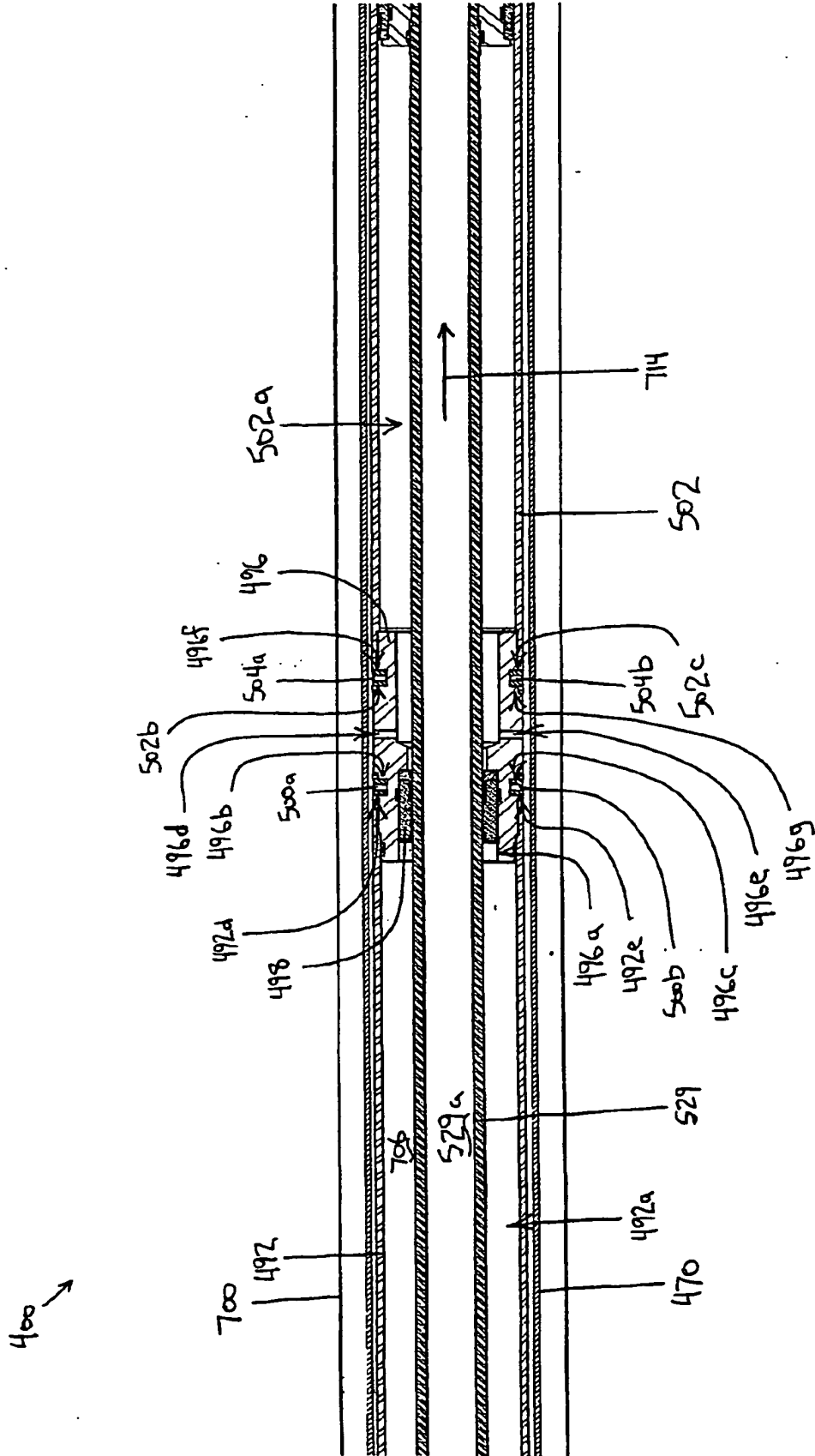
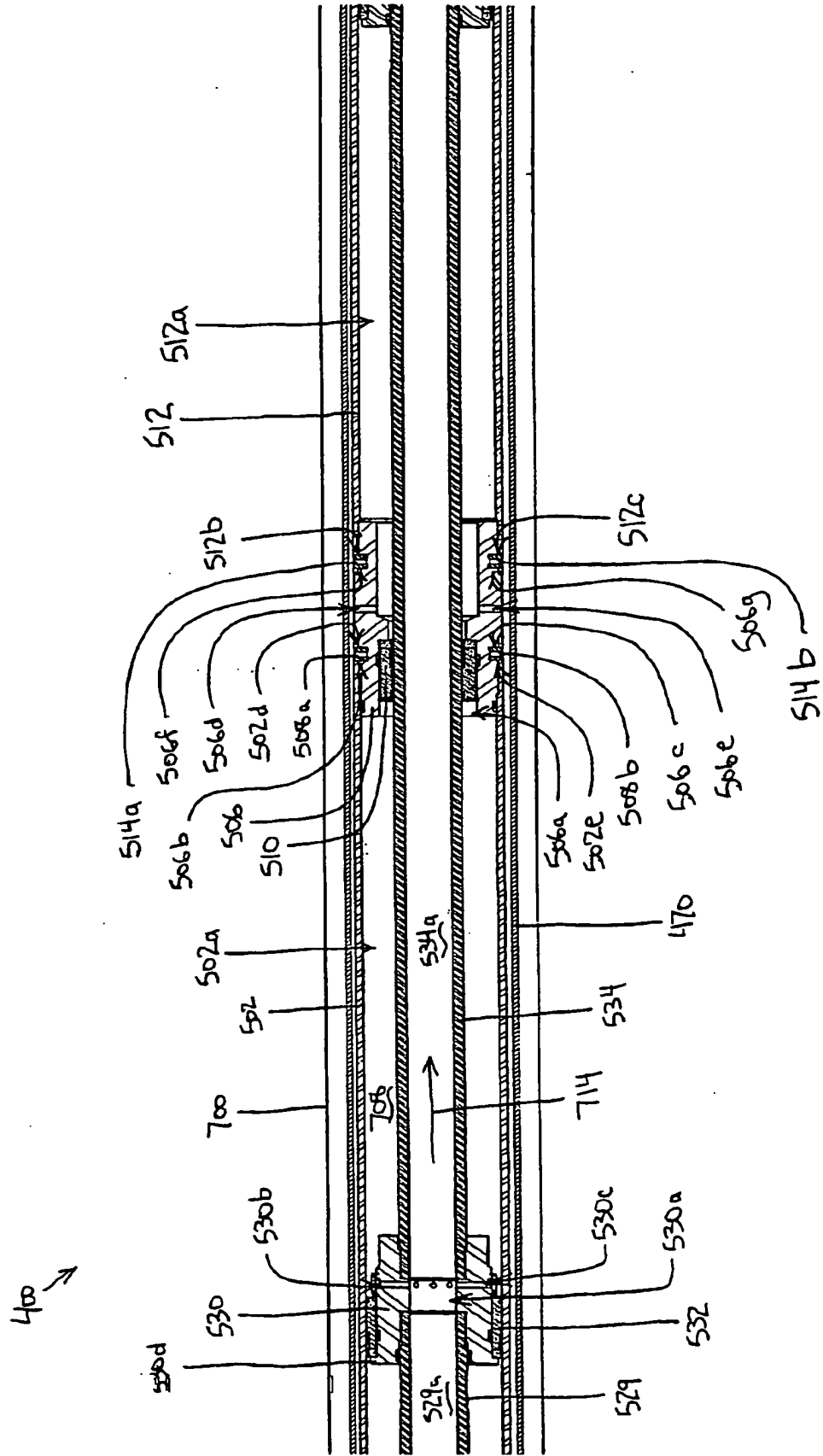

Fig. 33h





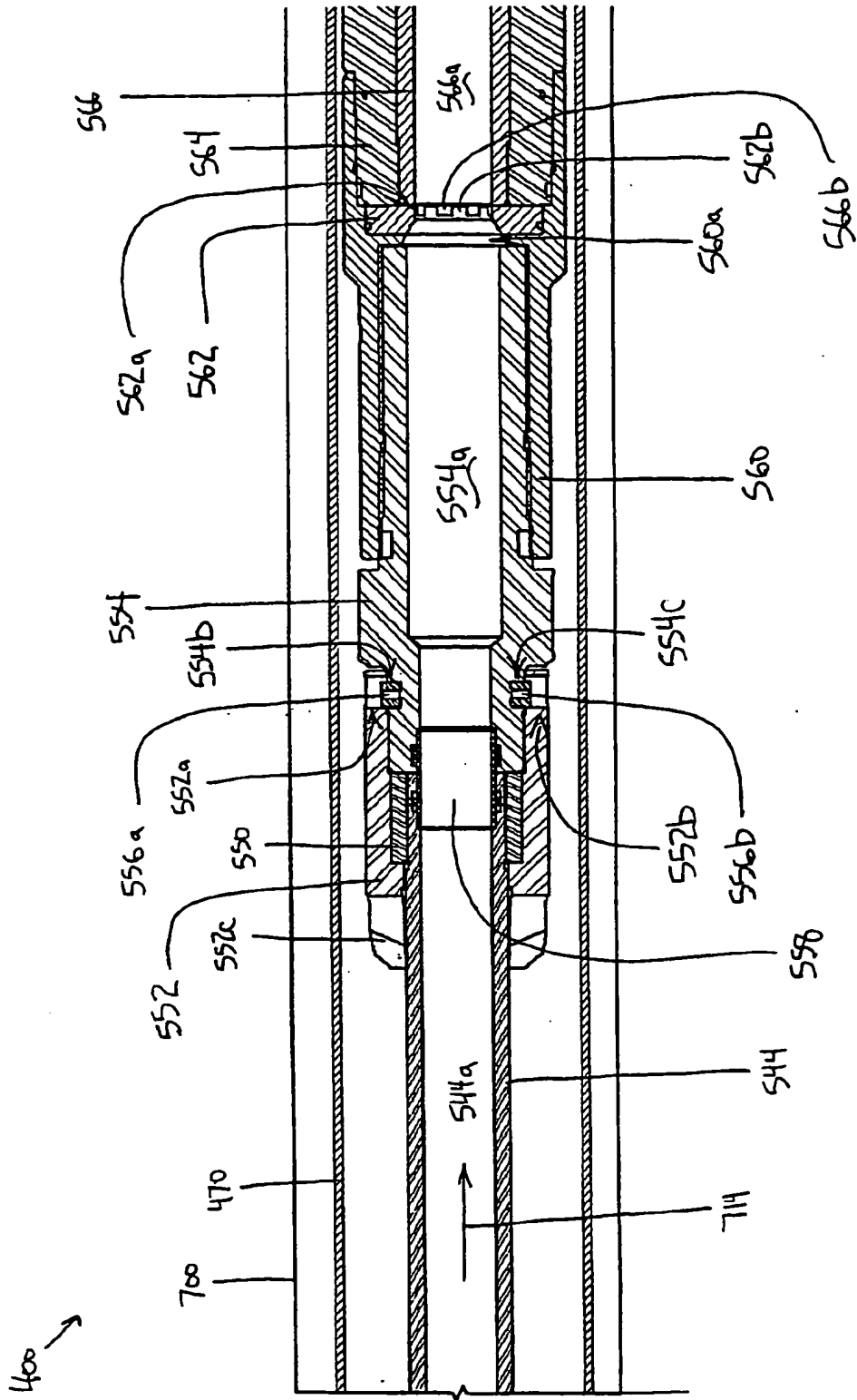

Fig. 33k



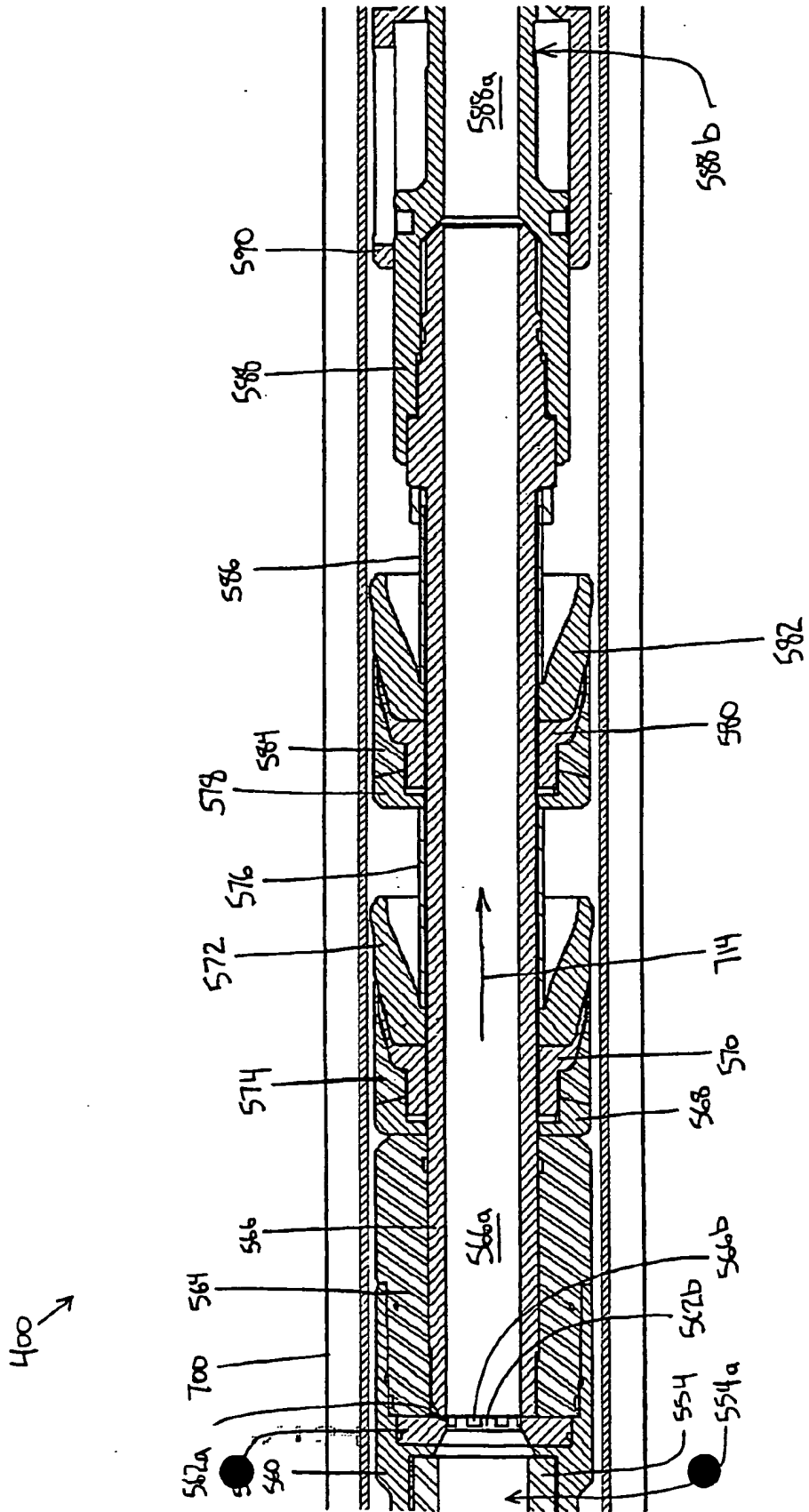

Fig. 331

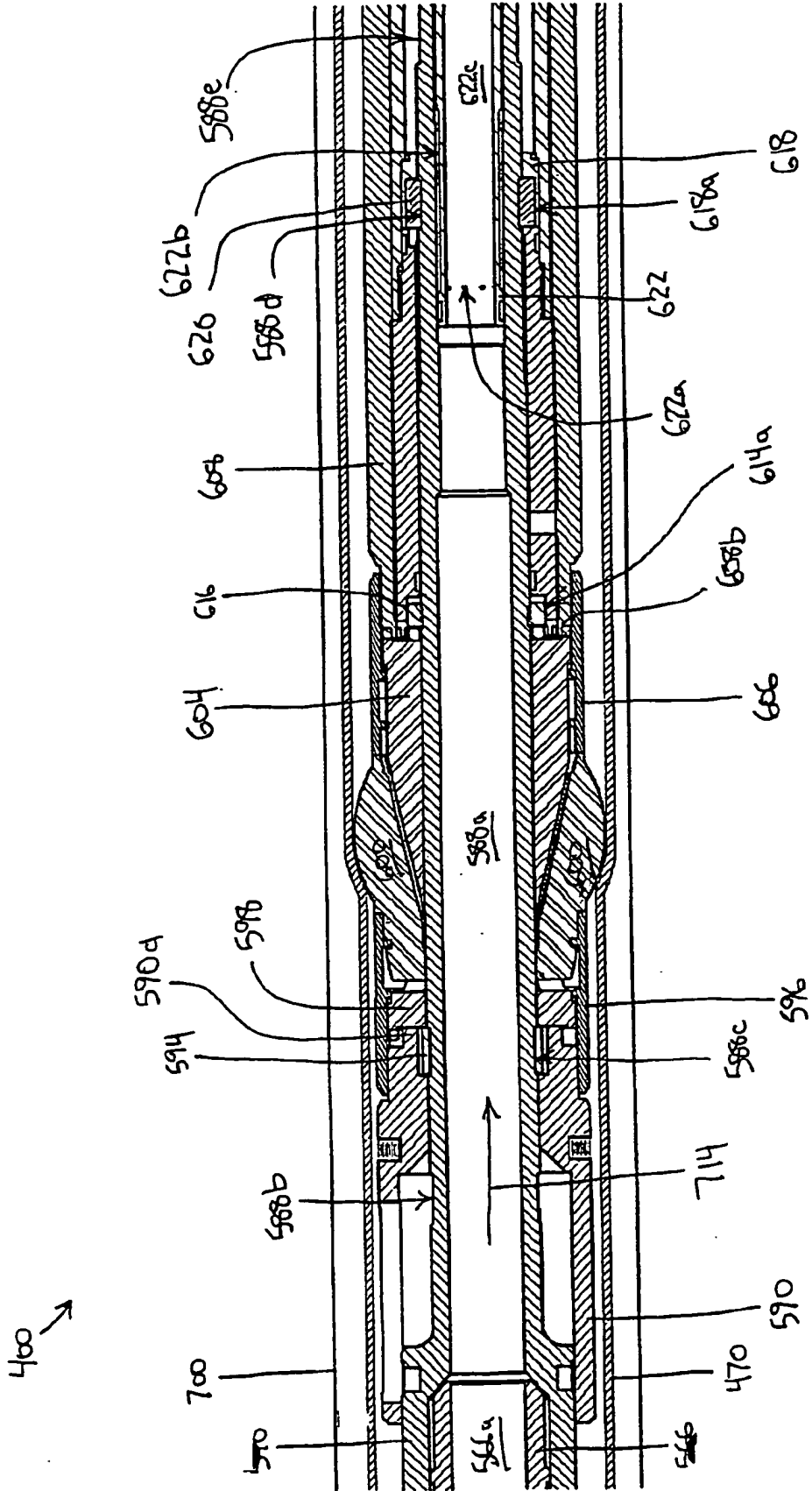

Fig. 33m

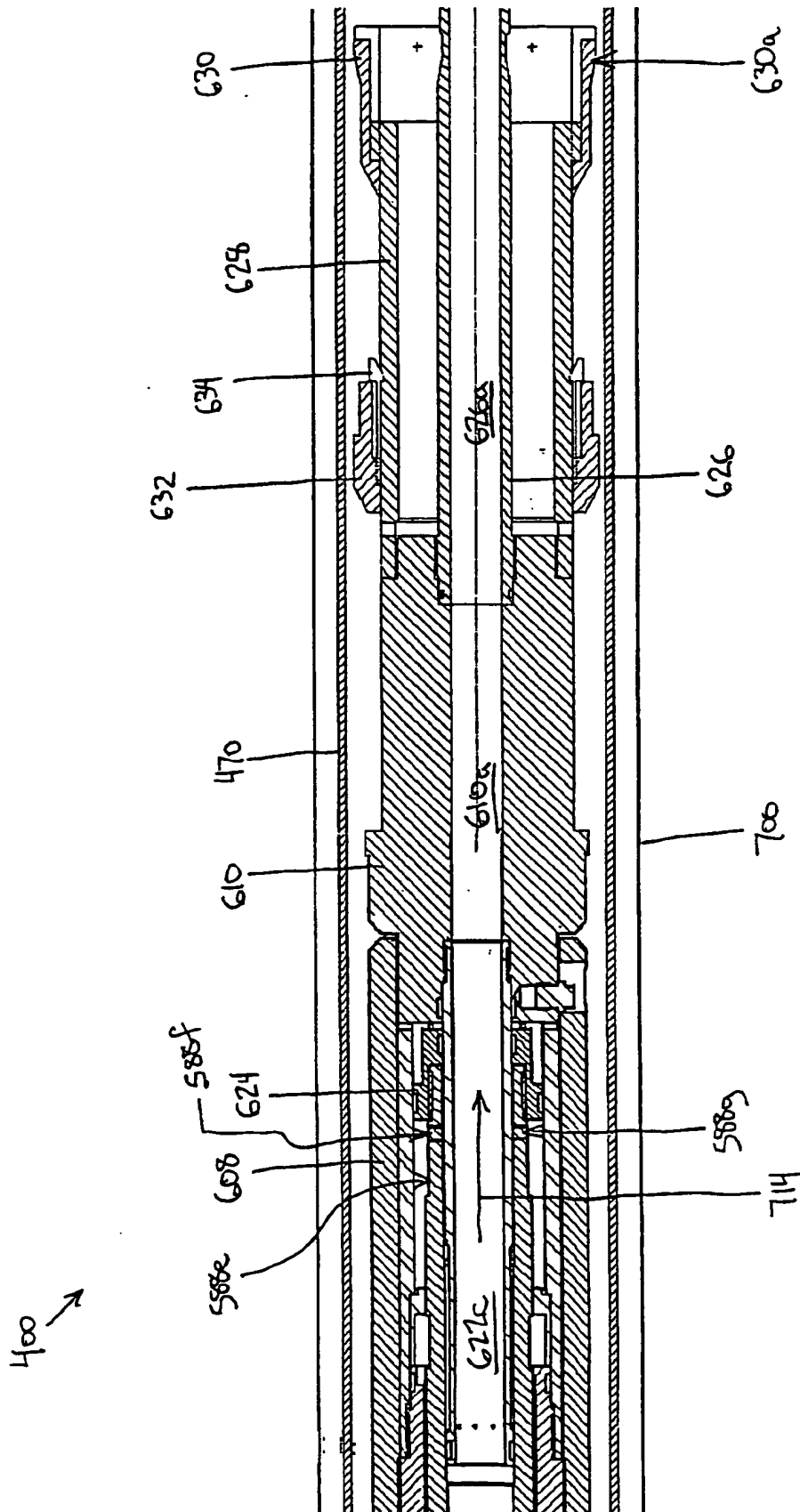

Fig. 33n



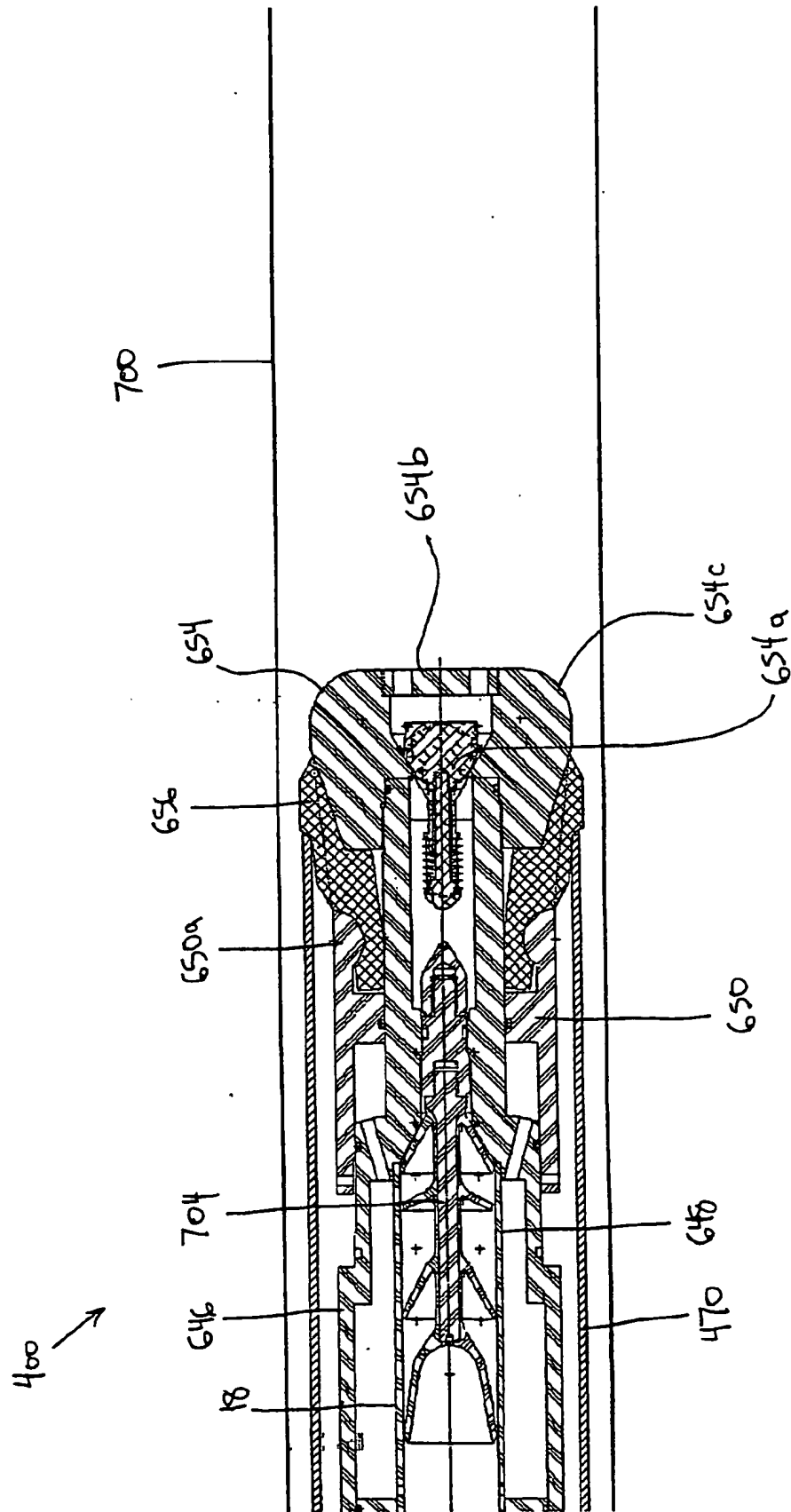

Fig. 33P

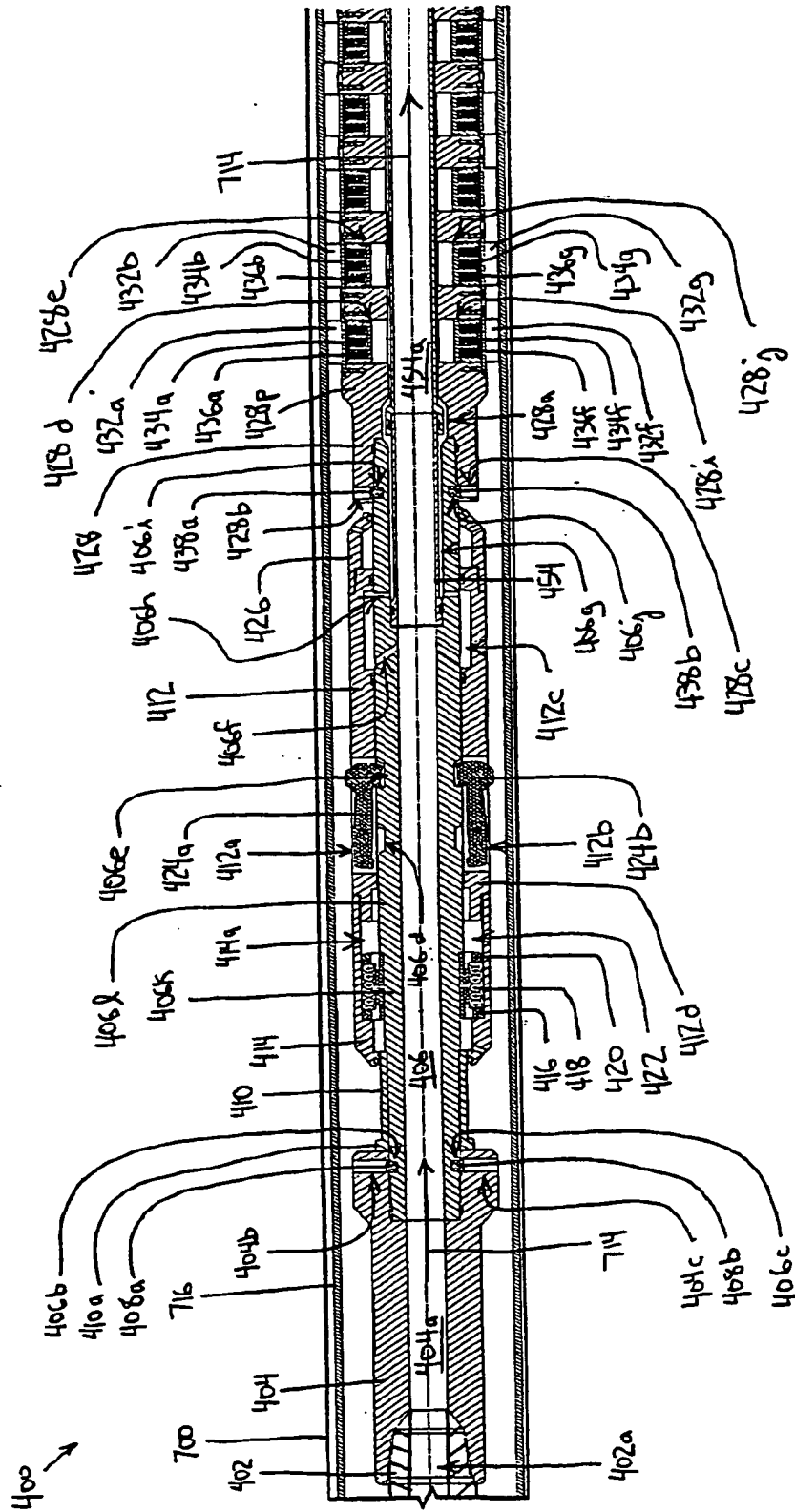

Fig. 34a



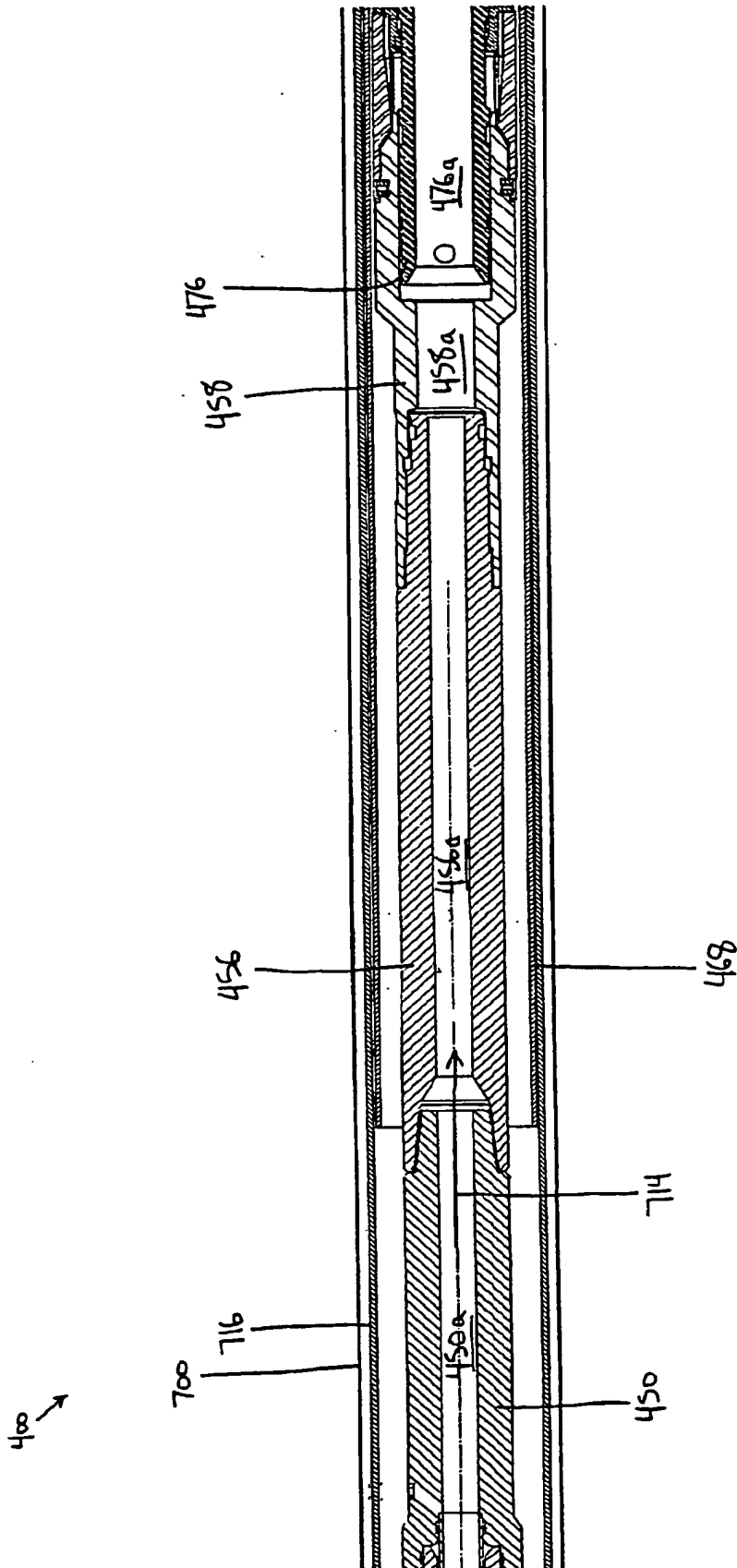

Fig. 34c



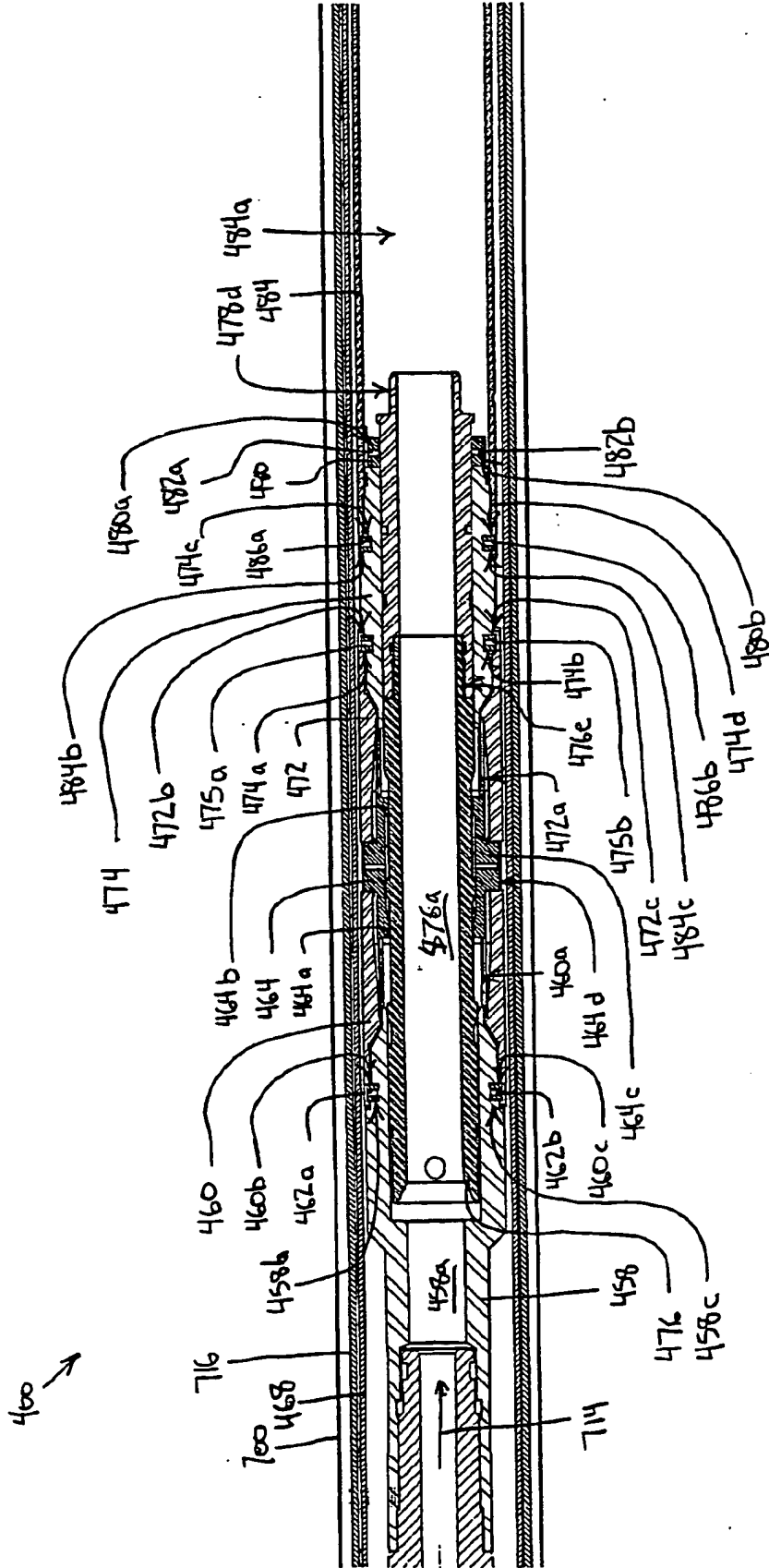

Fig. 34d

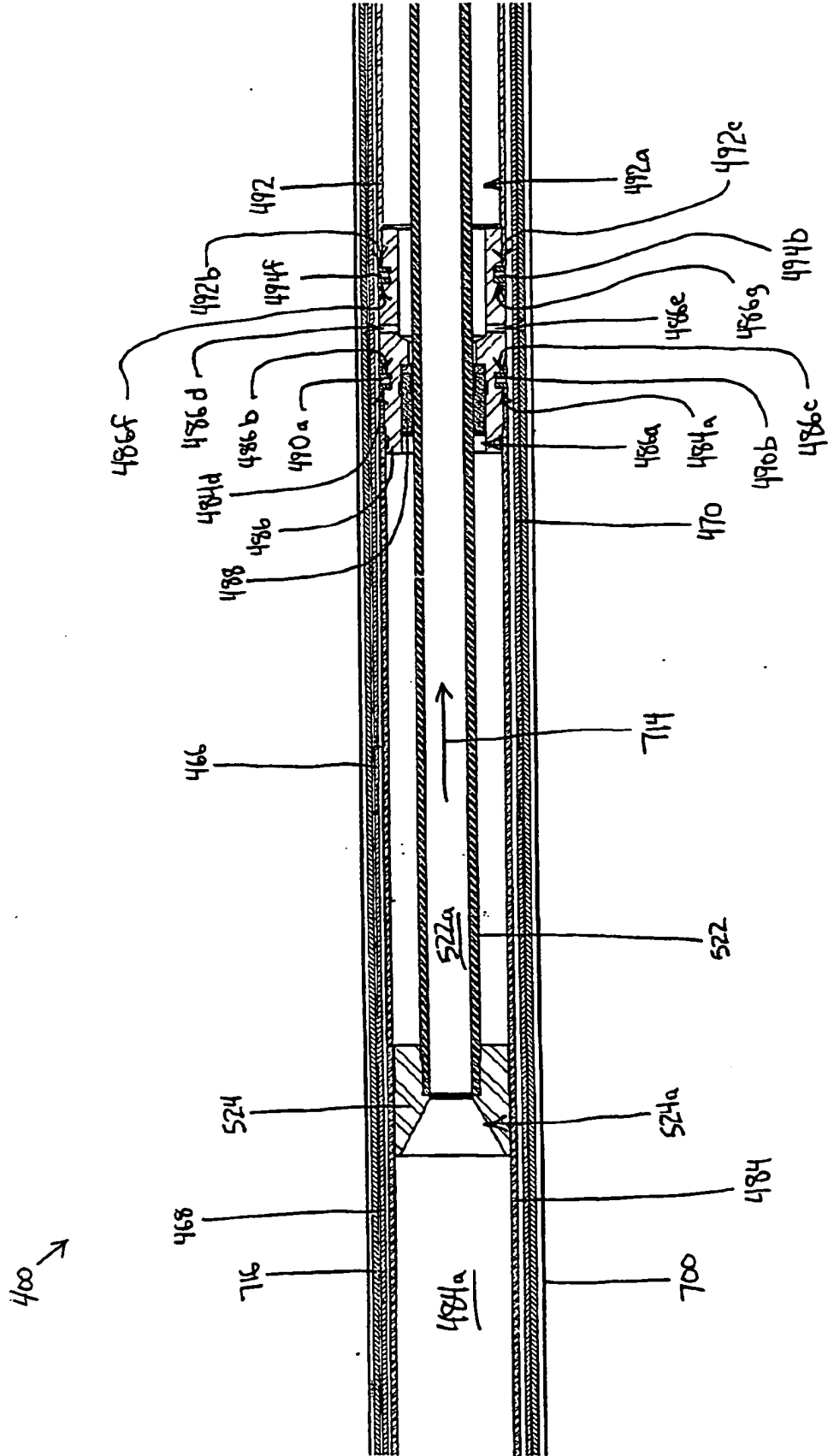

Fig. 34e

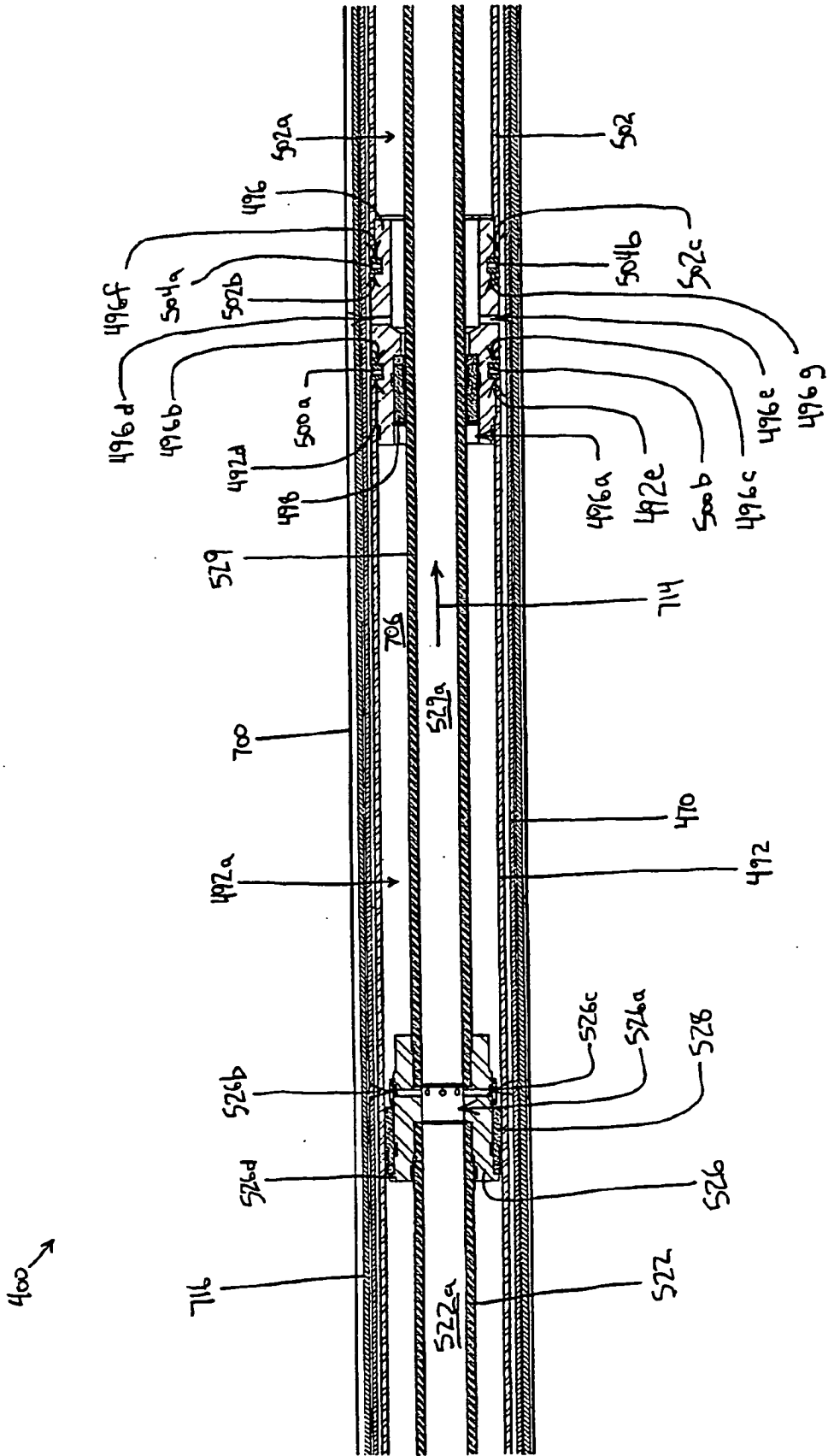

Fig. 34f

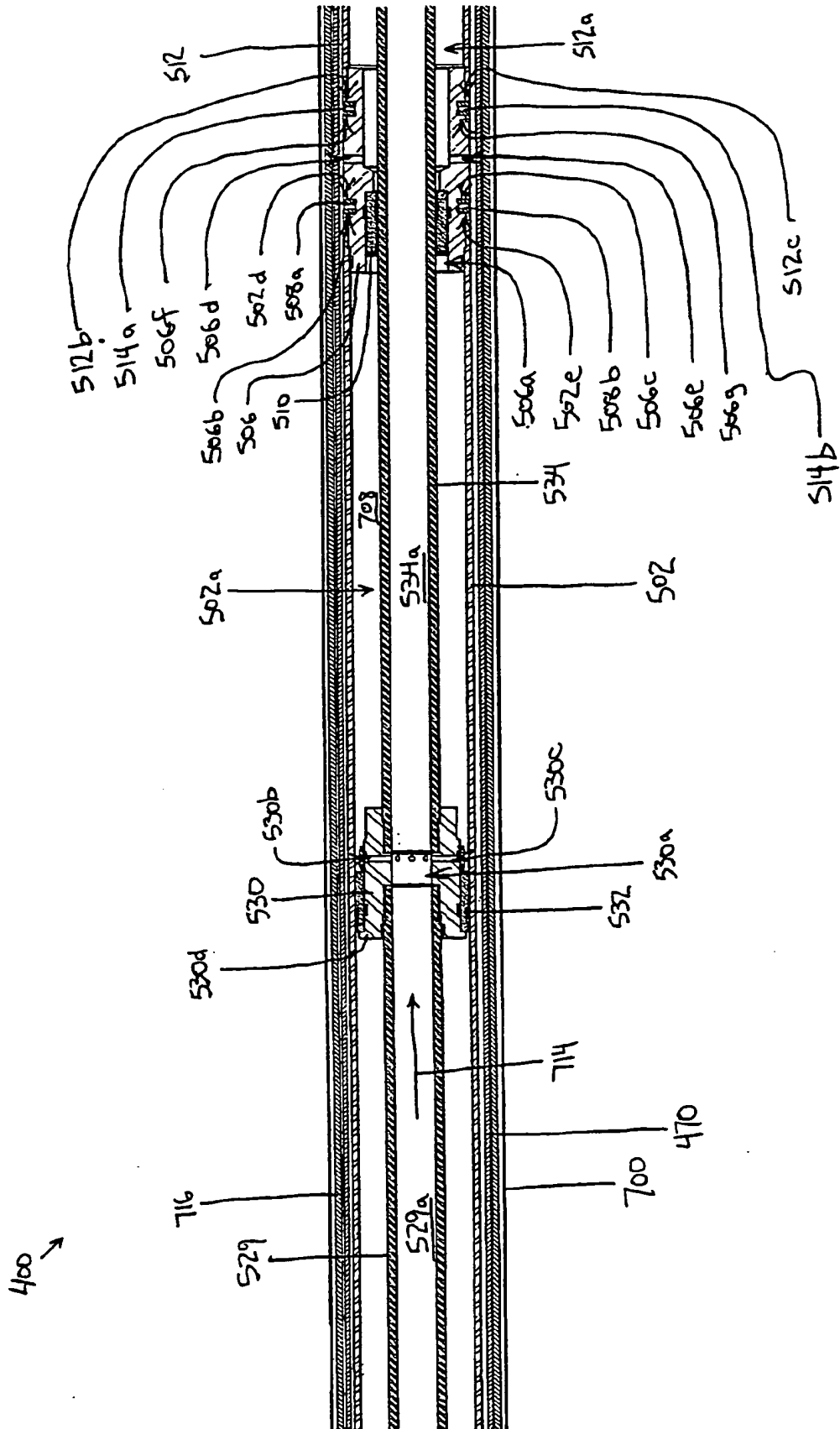

Fig. 349





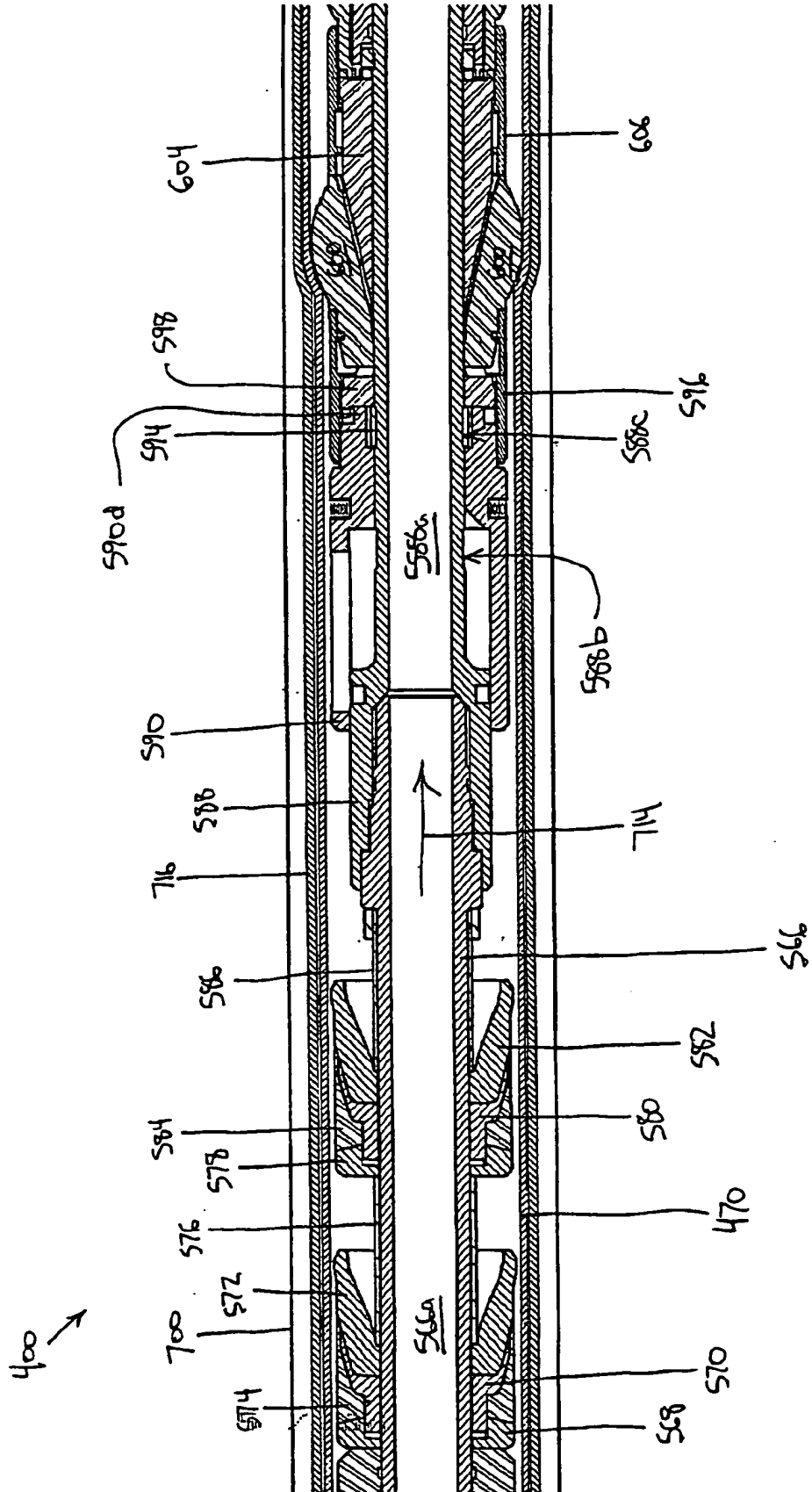

Fig. 34j







400 →

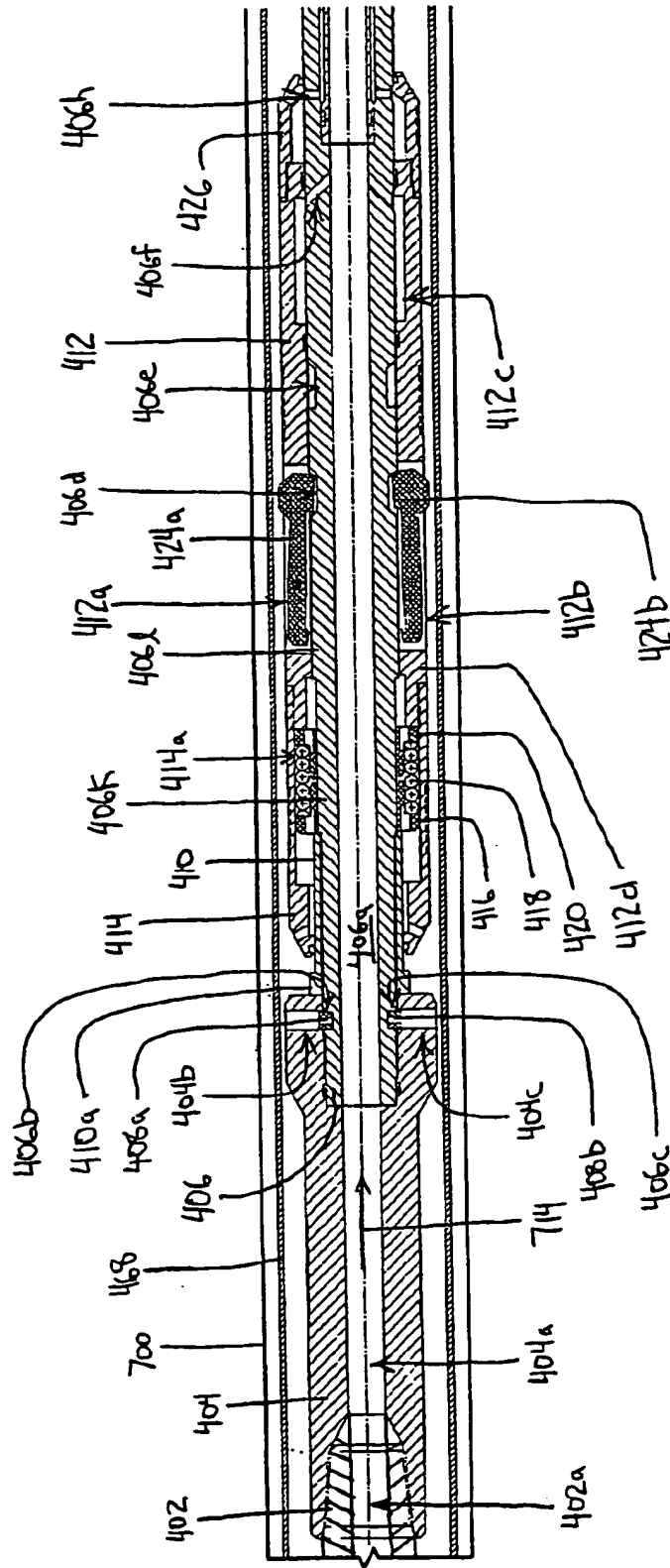

Fig. 35a





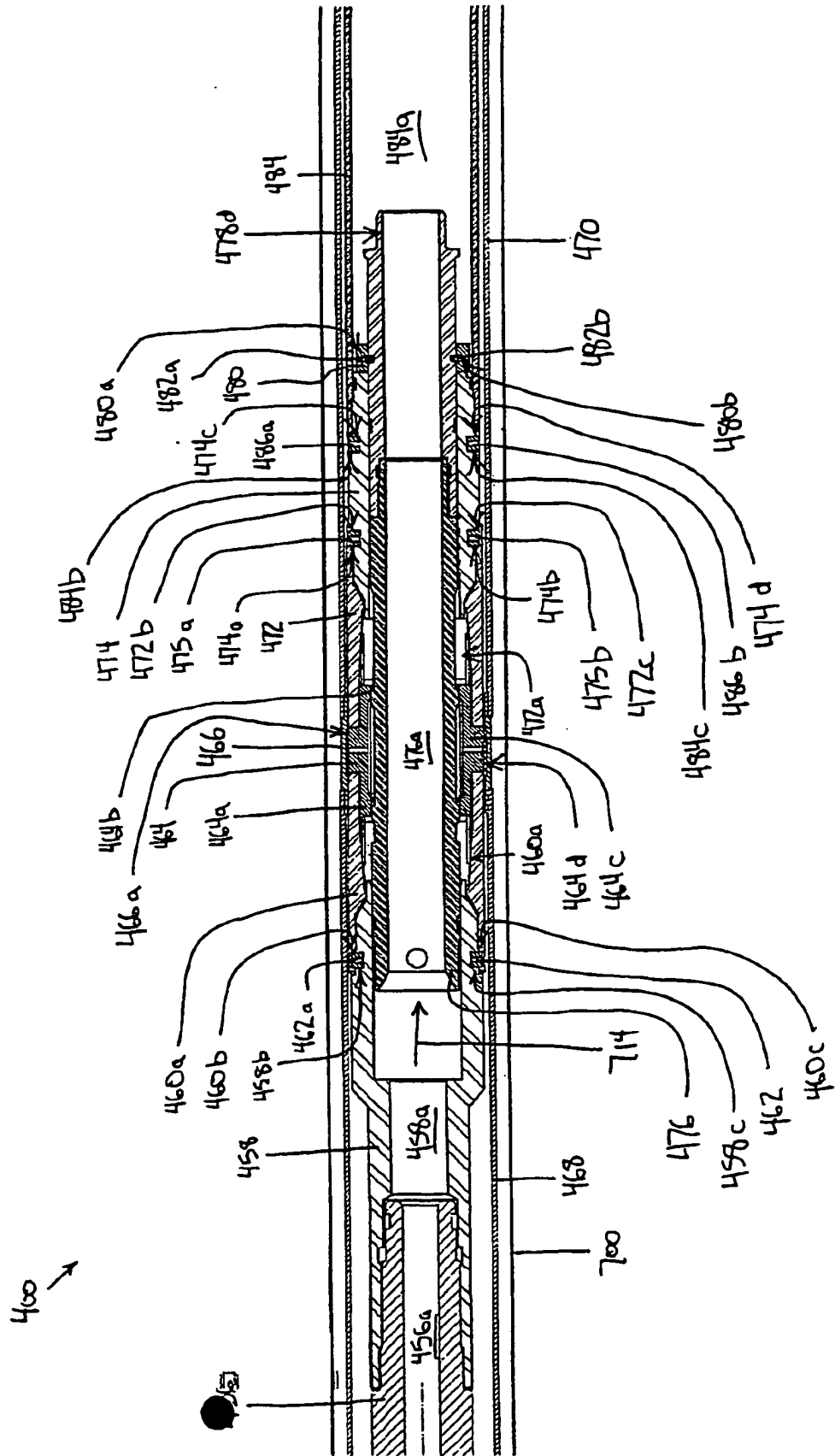

Fig. 35d



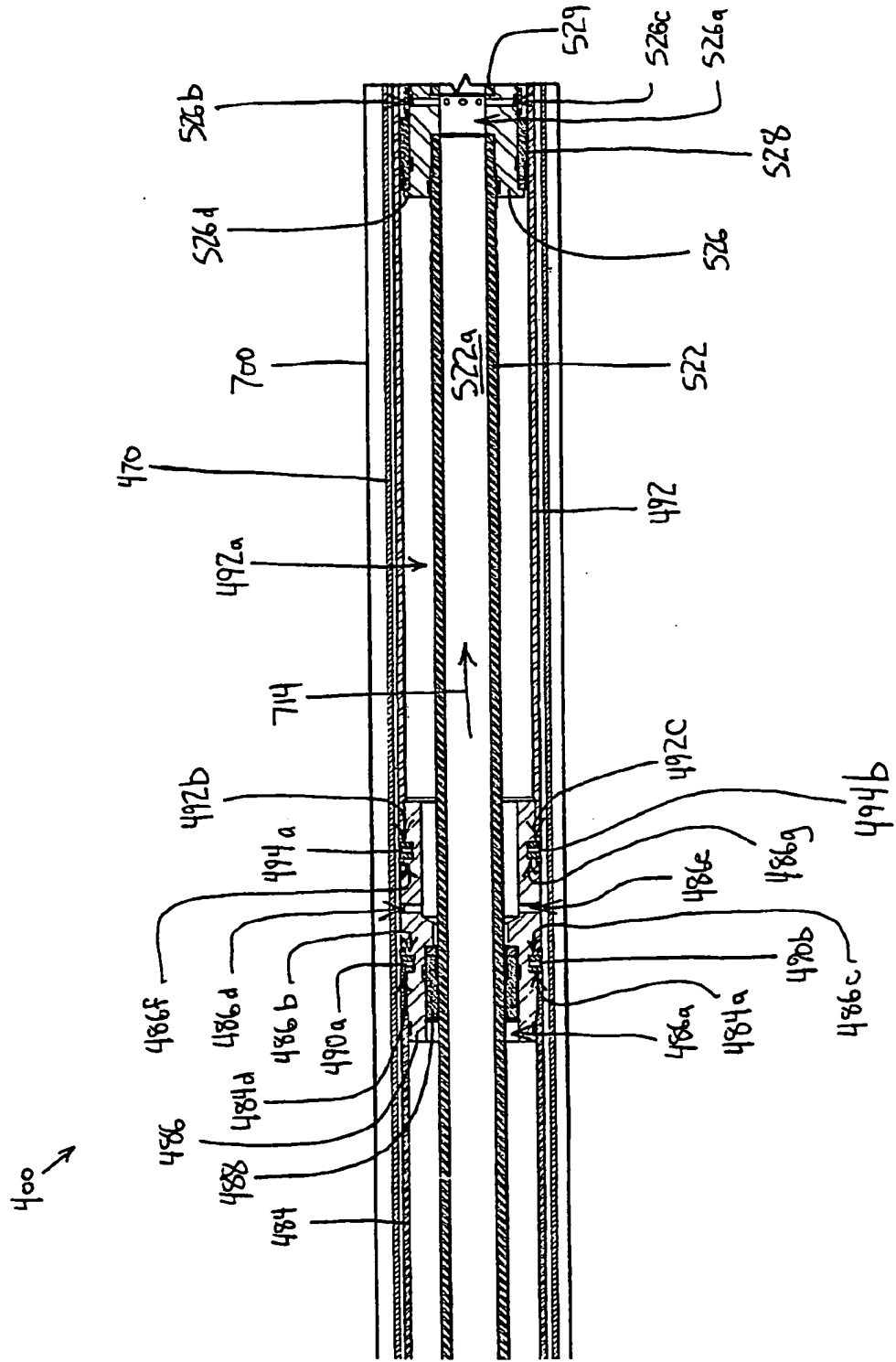

Fig. 35f

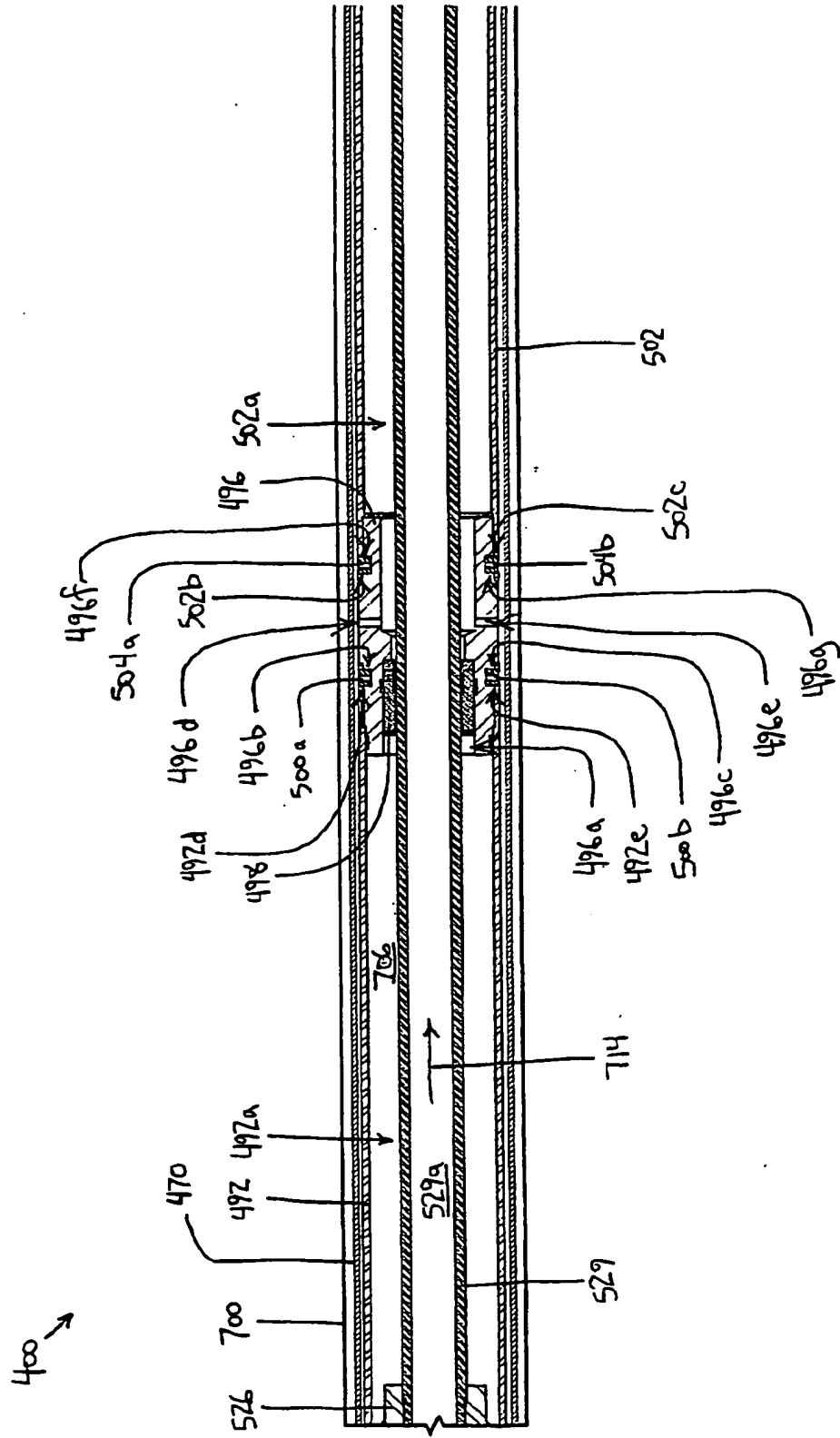

Fig. 35g



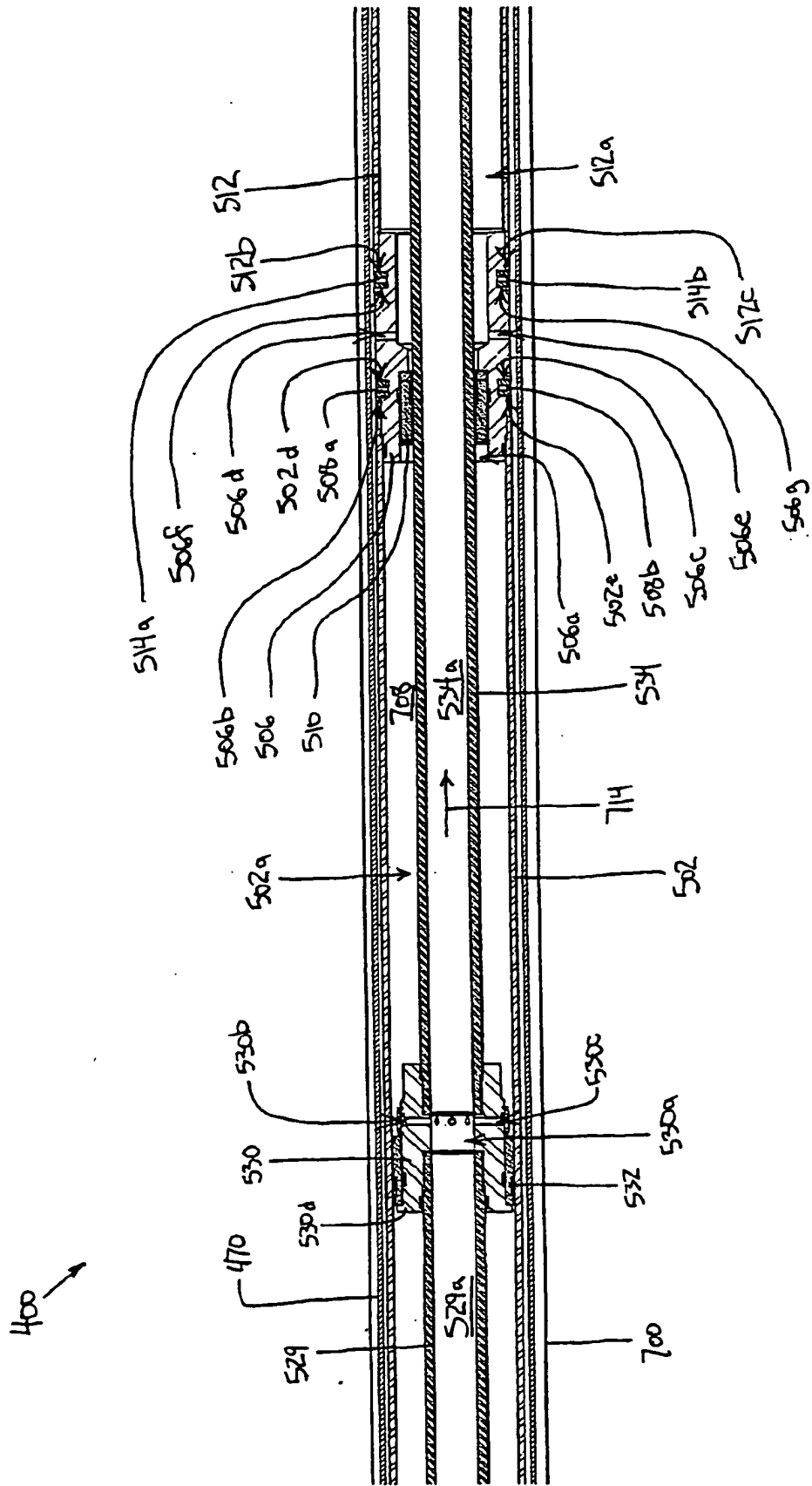

Fig. 35h

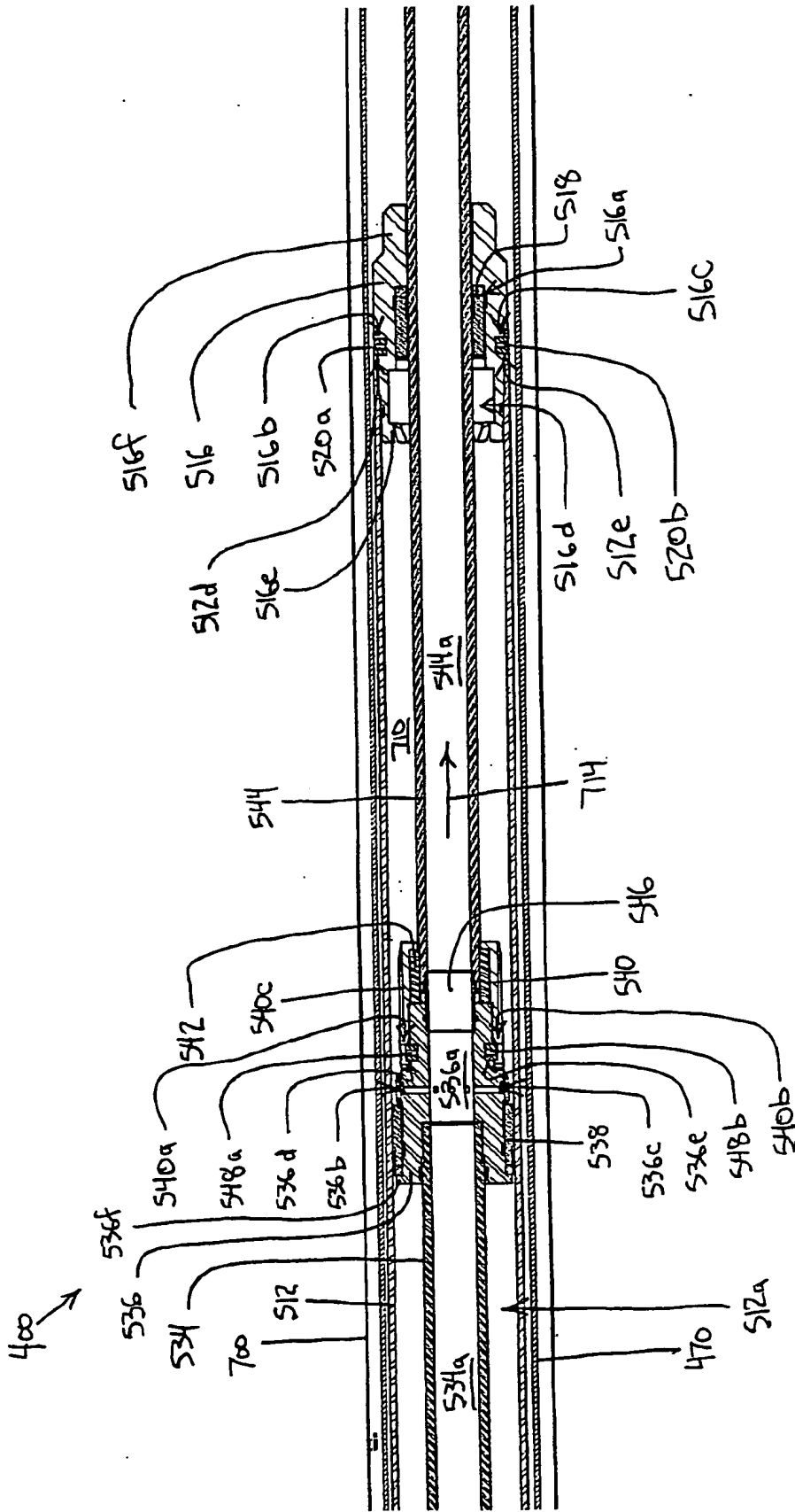

Fig. 35I

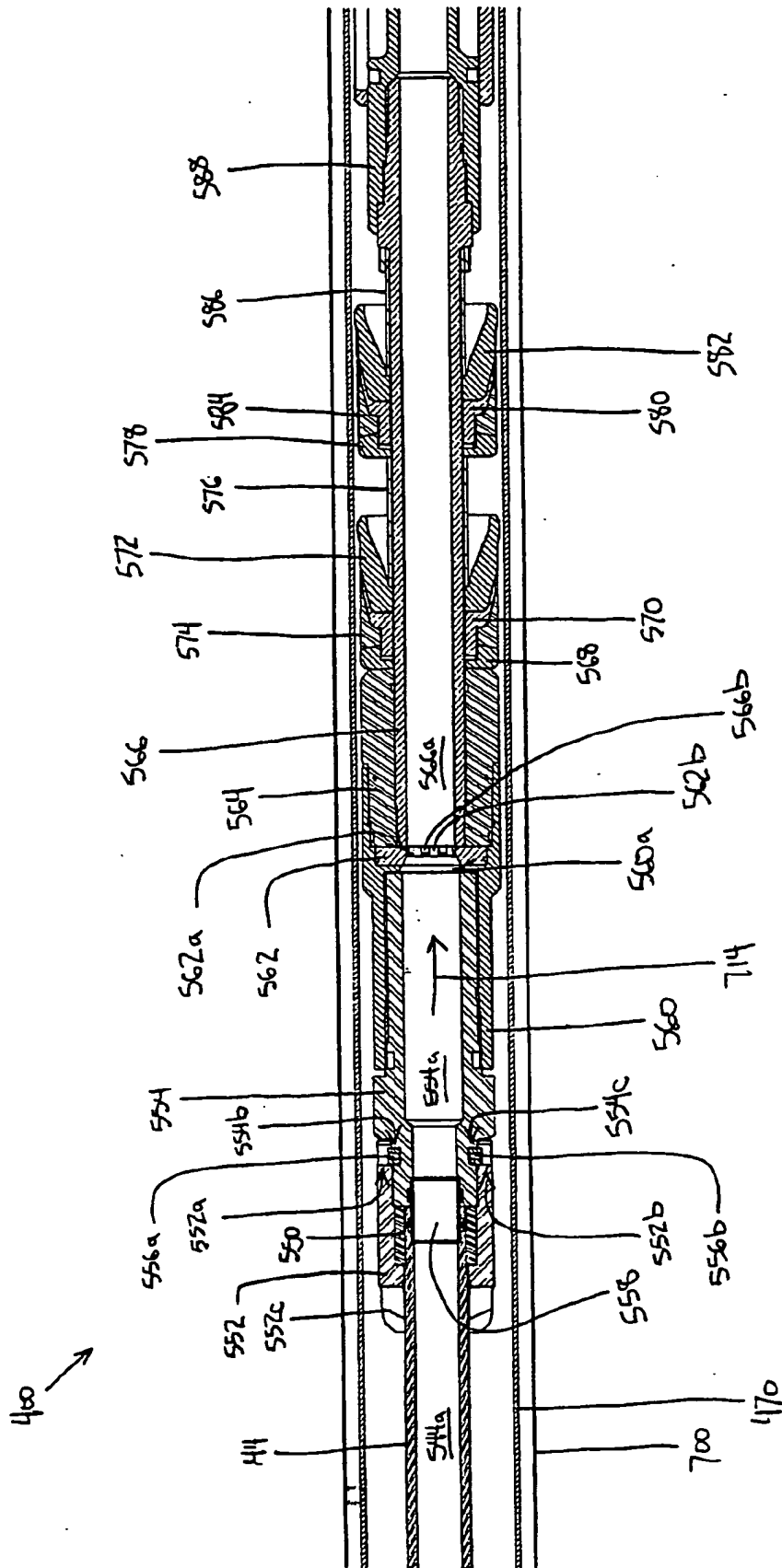

Fig. 35J

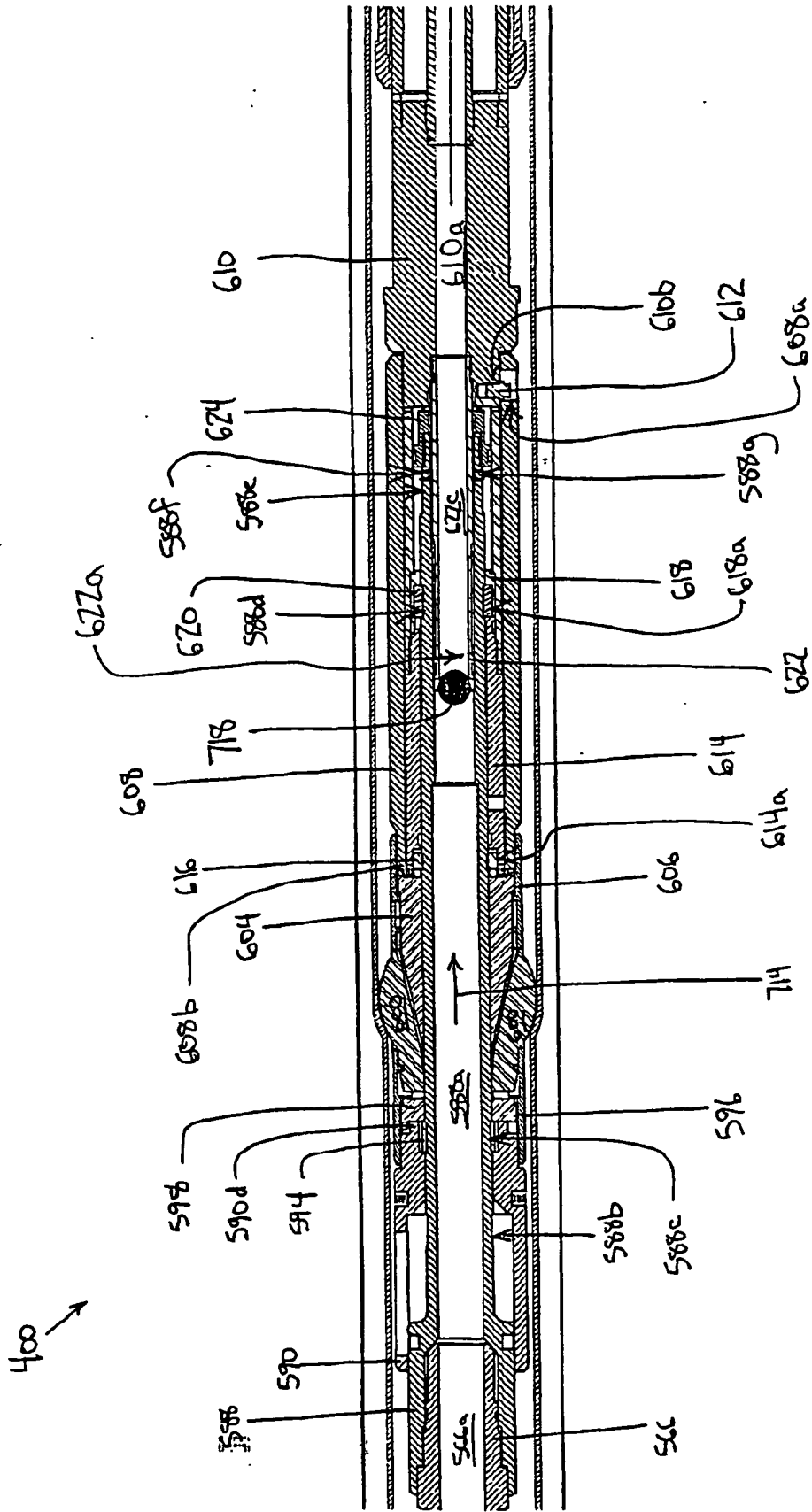

Fig. 35k

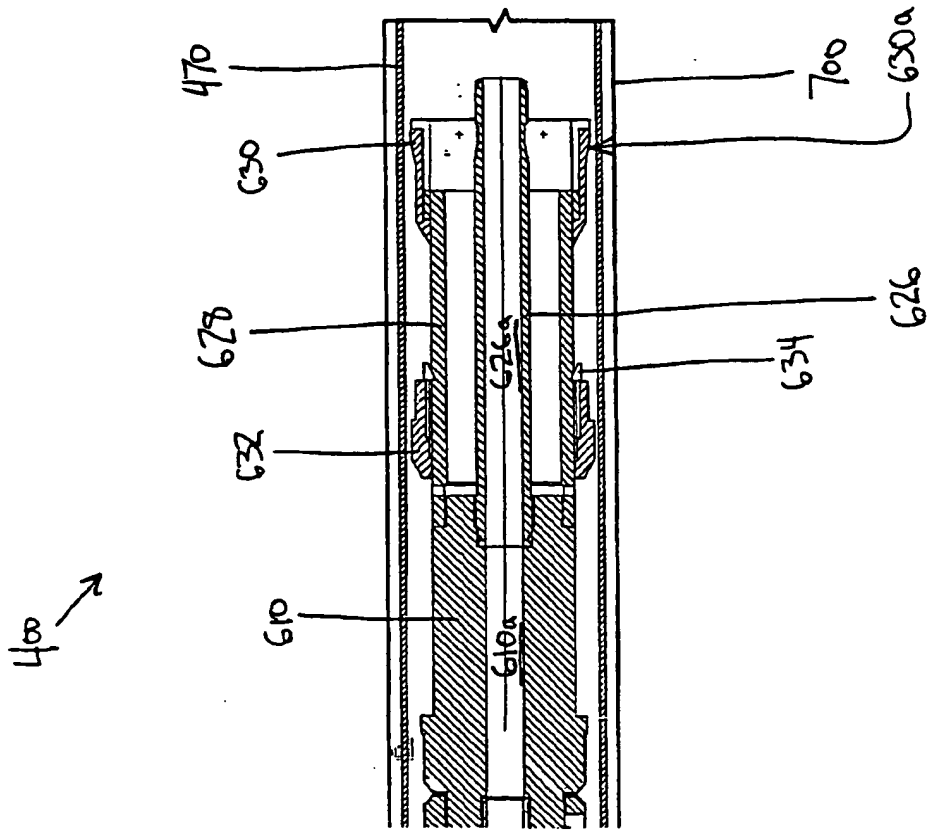

Fig. 35I



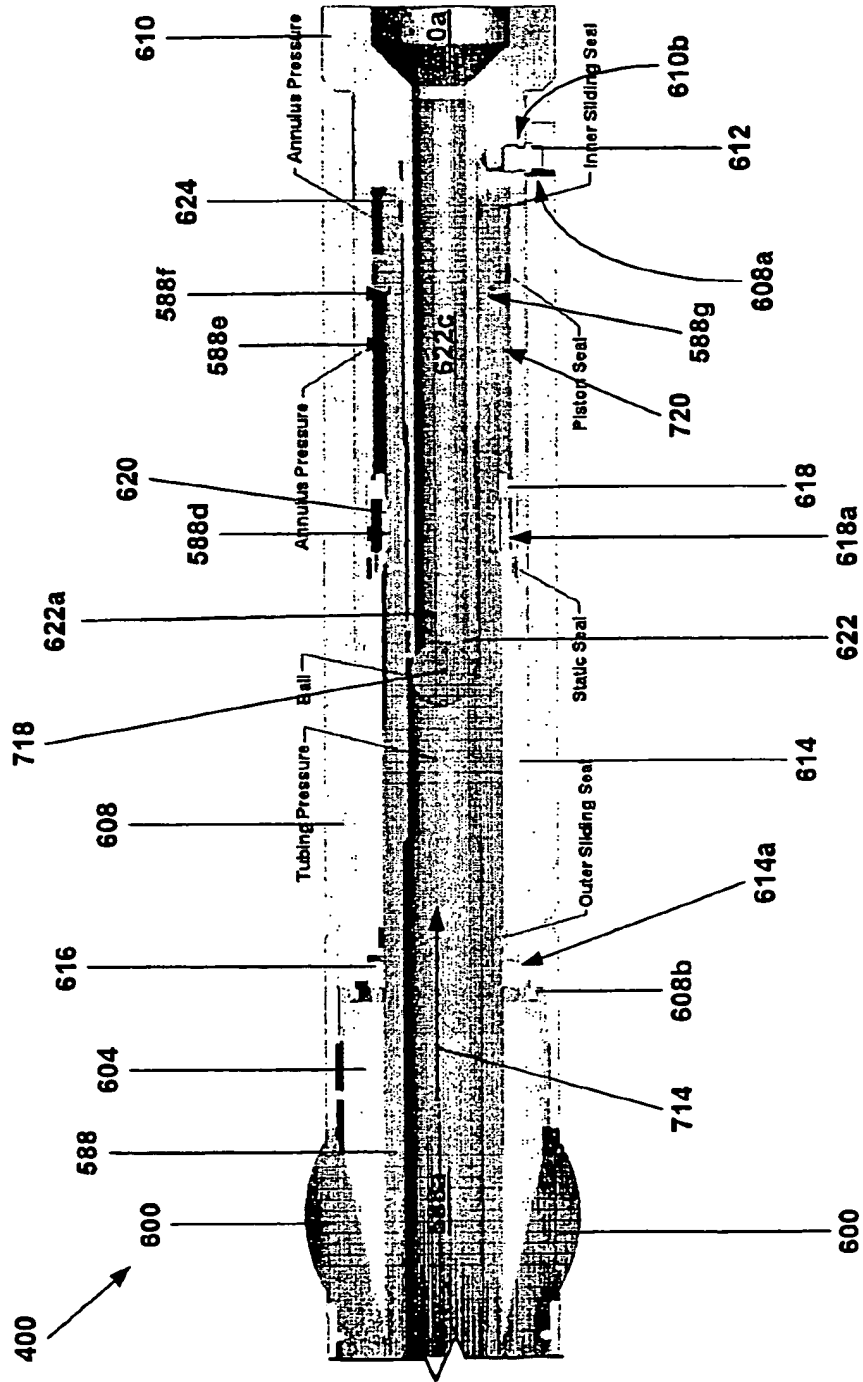

Fig. 36b